

**Lewis River Hydroelectric Projects Settlement Agreement  
Lewis River Recreation Coordination Committee (LRC)  
Meeting Agenda**

**Date & Time:**            **Wednesday, July 25, 2012**  
   **9:00 AM – 11:30 AM**

**Place:**                        **Merwin Hydro Control Center**  
   **105 Merwin Village Court**  
   **Ariel, WA 98603**

**Contacts:**                    **Lore Boles: (360) 225-4412**  
   **David Moore: (503) 813-6945**  
   **Kim McCune: (503) 813-6078**

<b>Time</b>	<b>Discussion Item</b>
9:00 AM	Welcome <ul style="list-style-type: none"> <li>➤ Preview Agenda</li> </ul>
9:10 AM	Completed Implementation Projects <ul style="list-style-type: none"> <li>➤ Yale Park Boat Ramp Extension &amp; Park Improvements</li> <li>➤ Cresap Bay Campground ADA Improvements</li> </ul>
9:30 AM	Ongoing Implementation Projects <ul style="list-style-type: none"> <li>➤ Merwin Park &amp; Marble Creek Trail Improvements</li> <li>➤ I&amp;E Program</li> <li>➤ Speelyai Bay Park Restroom</li> <li>➤ Cougar Day Use Restroom</li> <li>➤ Beaver Bay Trail</li> </ul>
<b>10:30 AM</b>	<b>Break</b>
10:40 AM	Ongoing Implementation Projects (continued) <ul style="list-style-type: none"> <li>➤ IP Road Trail Feasibility Study</li> <li>➤ Eagle Cliff Trail Amendment</li> </ul>
11:00 AM	Upcoming Implementation Projects <ul style="list-style-type: none"> <li>➤ Swift Day Use Facilities</li> <li>➤ Yale Lake Day Use Facilities</li> </ul>
<b>11:30 AM</b>	<b>Adjourn</b>

**Security procedure:** Upon arrival at the Merwin Hydro Control Center the gate will be closed and you will be required to use the call-in box on the left side of the gate; please announce who you are and the reason for your visit.

[Join online meeting](#)

<https://meet.pacificorp.com/kimberly.mccune/QGG53HZT>

Join by Phone

+1 (503) 813-5252 [Portland, Ore.]

+1 (801) 220-5252 [Salt Lake City, Utah]

+1 (855) 499-5252 [Toll Free]

[Find a local number](#)

Conference ID: 8085027

[Forgot your dial-in PIN?](#) | [First online meeting?](#)

**Meeting Notes  
Lewis River License Implementation  
Recreation Coordination Committee (LRC) Meeting  
July 25, 2012  
Merwin Hydro Control Center**

**LRC Participants Present (3)**

Peggy Miller, WDFW  
David Moore, PacifiCorp Energy  
Kimberly McCune, PacifiCorp Energy

<b>Assignments from July 25, 2012 meeting</b>	<b>Complete</b>
McCune: Email Yale Bridge (Merwin) Non-Motorized Boating Access Prelim Design to Peggy Miller and attach to meeting notes	<b>7/26/12</b>

**Opening, Review of Agenda and Meeting Notes**

David Moore (PacifiCorp) called the meeting to order @ 9:05 a.m. Moore noted that two additional items will be added to the agenda:

- Saddle Dam Equestrian Trail
- Yale Non-motorized

Moore informed the attendees that the Lewis River Recreation Committee (LRC) was established to communicate updates regarding recreation implementation as required by the Lewis River Settlement Agreement (SA) and its License which was issued on June 26, 2008. PacifiCorp was advised to conduct annual meetings to communicate our efforts in accordance with Section 11 of the SA.

Moore further explained that the Recreation Resource Management Plan (RRMP) [http://www.pacificorp.com/content/dam/pacificorp/doc/Energy\\_Sources/Hydro/Hydro\\_Licensing/Lewis\\_River/Recreation\\_Resource\\_Management\\_Plan\\_June\\_2008.pdf](http://www.pacificorp.com/content/dam/pacificorp/doc/Energy_Sources/Hydro/Hydro_Licensing/Lewis_River/Recreation_Resource_Management_Plan_June_2008.pdf) lays out what needs to be done at each facility to include the requirements of the Americans with Disabilities Act Site Evaluation for the Lewis River Recreation Sites (ADA). The ADA Evaluation was completed before the Lewis River license was issued and can be located on the Lewis River website at the following link, [http://www.pacificorp.com/content/dam/pacificorp/doc/Energy\\_Sources/Hydro/Hydro\\_Licensing/Lewis\\_River/07032007%20LR%20-%20Final%20ADA%20Evaluation.pdf](http://www.pacificorp.com/content/dam/pacificorp/doc/Energy_Sources/Hydro/Hydro_Licensing/Lewis_River/07032007%20LR%20-%20Final%20ADA%20Evaluation.pdf)

**Completed Implementation Projects**

- Yale Park Boat Ramp Extension & Park Improvements

*11.2.2.6 Yale ADA Accessibility Improvements. Upon Issuance of the New License (6/26/2008) for the Yale Project, PacifiCorp shall conduct an evaluation of ADA accessibility*

*needs using the ADAAG. PacifiCorp shall renovate existing facilities not otherwise planned for renovation at Yale Lake, between the first and seventh anniversaries of Issuance of the New License for the Yale Project, to comply with the ADA and ADAAG.*

*11.2.2.7 Yale Park Boat Launch. By the fourth anniversary of Issuance (6/26/2012) of the New License for the Yale Project, PacifiCorp shall complete the following at Yale Park: (1) extend one concrete boat ramp lane approximately 10 to 20 feet horizontally and 1.5 to 3 feet vertically, depending on topography; and (2) replace the existing floating boat docks.*

PacifiCorp completed design and permitting, addressed traffic flow, parking, public safety, added barriers and went beyond what the license required PacifiCorp to complete. Two lanes of the boat ramp were extended 20' to provide an elevation to launch at 468'. The site is open to the public all year round. The project was completed in October 2011.



Yale Park is a popular day use facility so PacifiCorp designated day use parking. In addition, ADA access was installed to the boat deck, new vault toilet was added with ADA access, and swimming access was added in addition to picnic tables. PacifiCorp has received considerable praise, although a number of plantings were stolen shortly after put in place. The project went well overall.

➤ **Cresap Bay Campground ADA Improvements**

*11.2.3.5 Merwin ADA Accessibility Improvements. Upon Issuance of the New License (6/26/08) for the Merwin Project, PacifiCorp shall conduct an evaluation of ADA accessibility needs using the ADAAG. PacifiCorp shall renovate existing facilities not otherwise planned for*

*renovation at Lake Merwin, between the first (6/26/09) and seventh anniversaries (6/26/15) of Issuance of the New License for the Merwin Project to comply with the ADA and ADAAG.*

PacifiCorp found that there was not reasonable ADA access to the Cresap Bay Campground day use area so it was modified for public safety and to allow for ADA access. In addition, an ADA picnic area was added along with campsites composed of compacted material ADA accessible amenities. The group area was improved to allow for ADA access to the shelter and the camp site was hardened for ADA accessibility. The project was completed in October 2011.

## **Ongoing Implementation Projects**

### ➤ Merwin Park & Marble Creek Trail Improvements

*11.2.3.3 Marble Creek Trail. By the fourth anniversary of Issuance of the New License (6/26/12) for the Merwin Project, PacifiCorp shall: (1) improve the existing half-mile Marble Creek non-motorized, multi-use trail to ADAAG standards; (2) remove the existing viewing platform; (3) evaluate the need for safety fencing at the trail terminus; (4) provide a bench or picnic table at the trail end; and (5) provide information about Marble Creek and the falls at the trail end.*

*11.2.3.8 Merwin Park Day Use Facilities. By the fourth anniversary of Issuance of the New License (6/26/2012) for the Merwin Project, PacifiCorp shall provide 2 new volleyball courts, 1 new children's play structure, and four new horseshoe pits at Merwin Park. The children's play structure shall cost no more than \$150,000.*

PacifiCorp filed an extension request with the Federal Energy Regulatory Commission (FERC) to complete the above requirements by August 2012. PacifiCorp went above and beyond as there was concern about erosion at the shoreline. PacifiCorp armored the bank which provided a nice fishing opportunity, added ADA accessible path, excavated and graded the slope and added 65 picnic tables throughout the park.

In addition, PacifiCorp received approval from US Fish & Wildlife Service (USFWS) to proceed with extending an ADA accessible path to the swimming area. Marble Creek will be complete by October 2012.

### ➤ Interpretation & Education Program (I&E)

*11.2.5 Interpretation and Education Program. To the extent feasible, PacifiCorp shall collaborate with Cowlitz PUD to produce a single Interpretation and Education Program ("I&E Program"). PacifiCorp shall develop, in consultation with Cowlitz PUD, a balanced and focused I&E Program for recreation opportunities on the lands within the Project Boundaries of its three Projects and the Lower Lewis River Access Sites by the first anniversary of the Issuance of the first of the New Licenses for its three Projects. In developing the I&E Program, PacifiCorp shall request comments from the Parties. PacifiCorp shall be required to spend no more than \$90,000 on I&E Program development. The I&E Program shall include a watchable wildlife component and may include educational efforts publicizing the locations of good fishing sites and what kinds of fish can be found at them. The I&E Program shall: (1) include sufficient details, specifications, and artwork for follow-on printing, production, constructing, and installation of I&E Program-identified materials (signs, kiosks, etc.) during the implementation*

*phase; (2) focus on recreation resources, hydro power generation, natural resources, and cultural resources; and (3) provide for the continuation and expansion of the weekend campfire programs to roughly double the effort as of the Effective Date to make campfire programs available at all PacifiCorp campgrounds at least one weekend night per week during July and August. Once the I&E Program is developed, PacifiCorp shall implement the I&E Program over a four-year period, starting for each Project on the first anniversary after Issuance of the New License for that Project. PacifiCorp shall not be required to spend more than \$20,000 per year to implement the I&E Program. Thereafter PacifiCorp shall maintain and upgrade signs, brochures, and other media, but shall not be required to spend more than \$7,500 per year on such maintenance and upgrades.*

PacifiCorp expanded the campfire program (July & August) at each camp site and contracted with the US Forest Service to conduct interpretative talks. Educational signage is being created which included the impact of the hydroelectric project and educate the public about dynamics of the hydroelectric project.

A brochure has been completed with information and amenities of each site. And, a fishing brochure has also been printed to educate the public about Bull Trout as a protected species.

PacifiCorp and its consultant has invested extensive effort to create the I&E Program. The consultant has conducted many interview, collected stories and photographs and created panels for both the Cowlitz Indian Tribe and the Yakama Nation, in addition to extensive consultation with the LRC. Fabrication of interpretive kiosks and panels are in process. Actively implementing the program which centers on recreation resources, hydro generation, natural resources and cultural resources of the Lewis River.

➤ Speelyai Bay Park Restroom

*11.2.3.10 Speelyai Bay Park Restroom. By the sixth anniversary of Issuance of the New License (6/26/2014) for the Merwin Project, PacifiCorp shall upgrade the existing restroom building at Speelyai Bay Park to meet ADAAG standards within the existing building envelope. If this is not possible because of building size limitations and use needs, PacifiCorp shall replace it with a new building that meets ADAAG standards.*

PacifiCorp conducted a feasibility study to renovate or to move this facility. There is limited real estate at this location in addition to cost prohibitive demolition cost/construction expense created limiting factors. It was determined that renovation was a better choice. The project is currently in the design phase and ready to permit. Moore provided an illustration of the design drawings which includes the installation of the following:

- New septic system
- Enhancing traffic flow and utilizing additional real estate
- Addition of ADA accessible path to day use area with new ADA picnic area
- Asphalt path
- Addition of path access from day use area to restroom and down to the boat ramp
- Addition of ADA boat trailer spot
- Addition of vault toilet
- Formalization of overflow parking

PacifiCorp is going beyond the SA requirements and addressing traffic flow and public safety in addition to the SA requirements.

Miller asked about drainage problems, if any, between the wetlands and the path. Moore said soils and presence of wetland species have designated these sites. Poor drainage is creating the wetland designation.

Construction completion is Fall 2013.

➤ **Cougar Day Use Restroom**

*11.2.2.11 Cougar Day Use Restroom. By the sixth anniversary of the Issuance of the New License (6/26/2014) for the Yale Project, PacifiCorp shall replace or renovate the day-use restroom at Cougar Day-Use Park to meet ADAAG standards.*

PacifiCorp conducted a feasibility study to determine the best alternative. The existing building was determined to be in good shape so the existing shell and access into the site will be modified by adding ADA showers and sinks to meet code. A new septic system, play structure, picnic tables and interpretive kiosk will also be added. Construction completion is Fall 2013.

➤ **Beaver Bay Trail (e) & Saddle Dam Equestrian Trail (c & d)**

*11.2.2.5 Yale Trails. By the fifth anniversary of Issuance of the New License (6/26/13) for the Yale Project, PacifiCorp shall complete the following capital improvements at Yale Lake:*

*a. PacifiCorp shall promote existing and new non-motorized, multi-use trails in the Yale Project area with signs and brochures.*

*b. PacifiCorp shall develop a non-motorized, multi-use, natural-surface trail between Saddle Dam Park parking lot and the existing Saddle Dam Trail at the northern end of Saddle Dam.*

*c. PacifiCorp shall improve parking outside of the gate at Saddle Dam Park to accommodate 5 to 10 vehicles with horse trailers and to provide one horse tie-up rail.*

*d. PacifiCorp and WDFW shall work cooperatively to develop a mutually agreeable strategy to evaluate the potential impacts of equestrian use on elk during the elk wintering season at Saddle Dam Farm and to minimize any impacts through signage and education, vegetation buffers, or relocating trails. If these methods are not feasible or successful and if equestrian use warrants, PacifiCorp shall, at the direction of WDFW, seasonally close the trail(s) via appropriate signage and gates.*

*e. PacifiCorp shall provide a new non-motorized, multi-use, natural-surface trail between Cougar Campground and Beaver Bay Campground, approximately 2 miles long.*

*f. PacifiCorp shall provide a 0.5-mile, non-motorized, multi-use, gravel surface trail loop from the public restroom at the town of Cougar to a reservoir overlook area and back.*

C) PacifiCorp is concerned about traffic flow so it abandoned the northern access road and created a new part entrance for the public safety. In addition, new parking stalls and additional

parking and ADA access has been added. The tie up rail has been moved and ADA parking added for restroom. Completion of construction is expected Fall 2012

D) Currently in the preliminary design phase for the Equestrian Trail. Expecting to submit State, County and Federal permit application by end of summer 2012. PacifiCorp conducted the Saddle Dam Farm elk study this past winter of which study will be presented to the Terrestrial Coordination Committee (TCC) for its review.

PacifiCorp took further steps to walk the access approximately a month ago and have concerns about ongoing erosion. Decisions are being made to formalize a trail route to block the present access to pioneer a route that keeps the public out of the field, away from interaction with the elk.

E) Currently in design phase. At the mouth of Beaver Bay wetland PacifiCorp has run into a topographical constraint. A delineation has been done and one option is a 700' boardwalk (no excavation needed) but we are finding it difficult to find a suitable elevation to avoid impacts to critical habitat. The second option is try to identify a northern boundary route. Completion is required by 6/26/13 but not likely we will make this deadline. Alder trees have been thinned to accommodate needed modifications.

PacifiCorp is confident it can construct the first portion of the trail but we may need to request an extension for the portion through the wetland.

➤ Yale Bridge Non-Motorized Boating Access

*11.2.3.7 Yale Bridge (Merwin) Non-Motorized Boating Access. By the sixth anniversary of Issuance of the New License (6/26/2014) for the Merwin Project, PacifiCorp shall: (1) provide an improved river access site at the Yale Bridge area for small, non-motorized watercraft launching and take-out; (2) install new steps and railings along the hillside slope from the gravel parking area next to the bridge to the reservoir shoreline; and (3) provide appropriate signage. PacifiCorp shall not be responsible for litter control in this area, which will be designated "pack it in/pack it out."*

Design phase has been completed and we are ready to submit the permit package. We are waiting for feedback relating to bull trout critical habitat concerns, if any. Consultation with Washington Department of Transportation was needed. We are currently formalizing entrance and exit. Worked with Clark county to accommodate a specific white water user group for Canyon Creek run. The given terrain creates limitations for ADA access so a sign will be installed informing that ADA access is .9 miles at Cresap Bay.

<Break 10:30am>

<Reconvene 10:40am>

**Ongoing Implementation Projects (cont'd)**

➤ IP Road Trail Feasibility Study

*11.2.2.2 Yale/IP Road Phase One. PacifiCorp shall use best reasonable efforts after Issuance of the New License for the Yale Project to secure, at the lowest cost possible, non-*

*motorized multi-use recreational access on the existing Yale/IP Road from the bridge over the Lewis River at the eastern terminus to Healy Road to the west. If a continuous trail is not achievable in the near term, PacifiCorp shall pursue an out-and-back trail. PacifiCorp shall secure access, complete bridge safety evaluations, rock-fall hazard assessments, design for bridge safety retrofit, engineering, and permitting by the fourth anniversary of Issuance of the New License for the Yale Project, at a cost not to exceed \$500,000. If efforts to secure access are not achieved by the fourth anniversary of Issuance of the New License for the Yale Project, PacifiCorp shall make reasonable efforts to secure such access. Should these efforts cost less than \$500,000, PacifiCorp shall add the remaining funds to the budget required under Section 11.2.2.3. The measures required by this Section 11.2.2.2 comprise “Phase One” of the Yale/IP Road measures.*

Moore informed the attendees that there are considerable access issues with this project. There are a number of land owners that have grandfather easements which are not well documented. In 2002-2003 the road was in good condition, but greatly deteriorated since then. The feasibility study is currently in draft form. PacifiCorp hired a consultant team to assess the rock fall, shoreline erosion and bridges to come up with a proposal. One of the landowners, Weyerhaeuser will not expand PacifiCorp’s utility use easement to public access and Department of Natural Resources (DNR) advised PacifiCorp that they are not interested in modifying its easement to allow public access. DNR wants to continue to have the ability to use the road for logging purposes. The feasibility study focuses on issues relating to PacifiCorp land only. The costs have escalated dramatically and the road is currently in very bad condition.

PacifiCorp will be requesting an extension from the FERC to file the plan by March 2013.

PacifiCorp will propose to make necessary improvements on its lands, but our hands are tied on lands owned by other parties.

➤ Eagle Cliff Trail Amendment

*11.2.1.2 Eagle Cliff Trail. Subject to obtaining acceptable minimal cost easements, PacifiCorp shall develop a trail connection between Eagle Cliff Park and the USDA-FS boundary. Trail facilities shall include the engineered trail, signage, and resource protection as appropriate. PacifiCorp shall conduct a detailed trail routing study in the first year of the New License for the Swift No. 1 Project. Criteria to be used in this study include locating a safe, economical, and buildable trail route and avoiding potential impacts on bull trout, to the extent practicable, by locating the trail away from sensitive habitat areas. PacifiCorp shall coordinate with and obtain the approval of USFWS on the final designs and location of the trail to ensure that impacts on bull trout are acceptable. PacifiCorp shall engineer, design, and permit the trail as soon as practicable following completion of the trail routing study. Subject to obtaining necessary easements, Permits, and USFWS approval, construction will commence on the 4<sup>th</sup> anniversary of Issuance of the New License for the Swift No. 1 Project. If necessary easements and Permits are not obtained by the 4<sup>th</sup> anniversary of Issuance of the New License for the Swift No. 1 Project, PacifiCorp shall make reasonable efforts to obtain such easements and Permits, and shall commence construction after obtaining such easements and Permits.*

PacifiCorp completed a feasibility study of which USFWS and Washington Department of Wildlife (WDFW) opposed the trail as it could have “significant impacts on bull trout”.

PacifiCorp submitted the study and comments to the FERC and asked for guidance. A verbal recommendation was made to file for an amendment of SA 11.2.1.2, Article 406 of the license.



Based on the feasibility study and comments received from USFWS and WDFW, no likely that PacifiCorp will construct this trail.

### **Upcoming Implementation Projects**

➤ Swift Day Use Facilities

*11.2.1.5      Swift Day Use Facilities.*

*11.2.1.5.1      Picnic Shelter. By the fifth anniversary of Issuance of the New License for the Swift No. 1 Project, PacifiCorp shall provide a new day-use group picnic shelter in the day use area of the Swift Forest Campground. PacifiCorp shall make this shelter available for reservations.*

This project is planned for next June 2013. PacifiCorp will design, permit and construction a new picnic shelter at Swift Forest Camp. No in-water work needed so it's a straight forward construction project.

➤ Yale Lake Day Use Facilities

*11.2.2.10      Yale Lake Day Use Facilities. By the seventh anniversary of Issuance of the New License for the Yale Project, PacifiCorp shall complete the following at Yale Park: (1) better define and expand the parking lot; and (2) provide a new day use group picnic shelter in the day use picnic area at Yale Park, Cougar Park, or Beaver Bay. The shelter must be placed where users can access the shoreline to beach boats. Upon completion, PacifiCorp shall make the new group picnic shelter available on a reservation system.*

Moore informed the attendees that this is a very windy location, the existing substrate is big rocks and the site is not suitable for this kind of amenity. PacifiCorp is proposing Saddle Dam Day Use area as the substrate is small (cobble) and protected from the wind. PacifiCorp could site a shelter out on the point. The FERC requires a plan submittal prior to construction so PacifiCorp will include the logic in its submittal as to why Saddle Dam is the selected site.

<11:30 a.m. meeting adjourned >

### **Public Comment**

None

### **Meeting Handouts & Attachments (sent via e-mail)**

➤ Agenda for 7/25/12

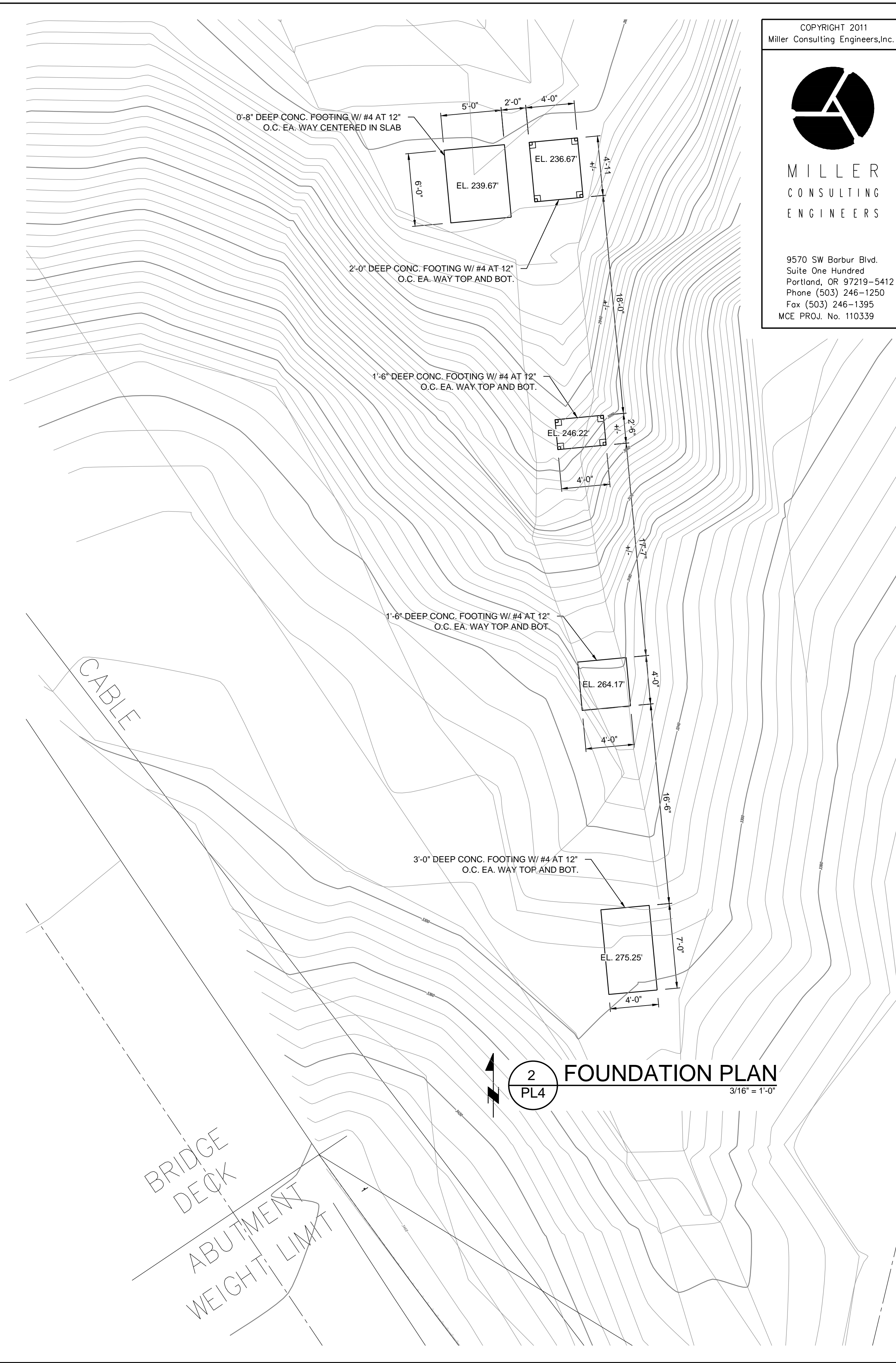
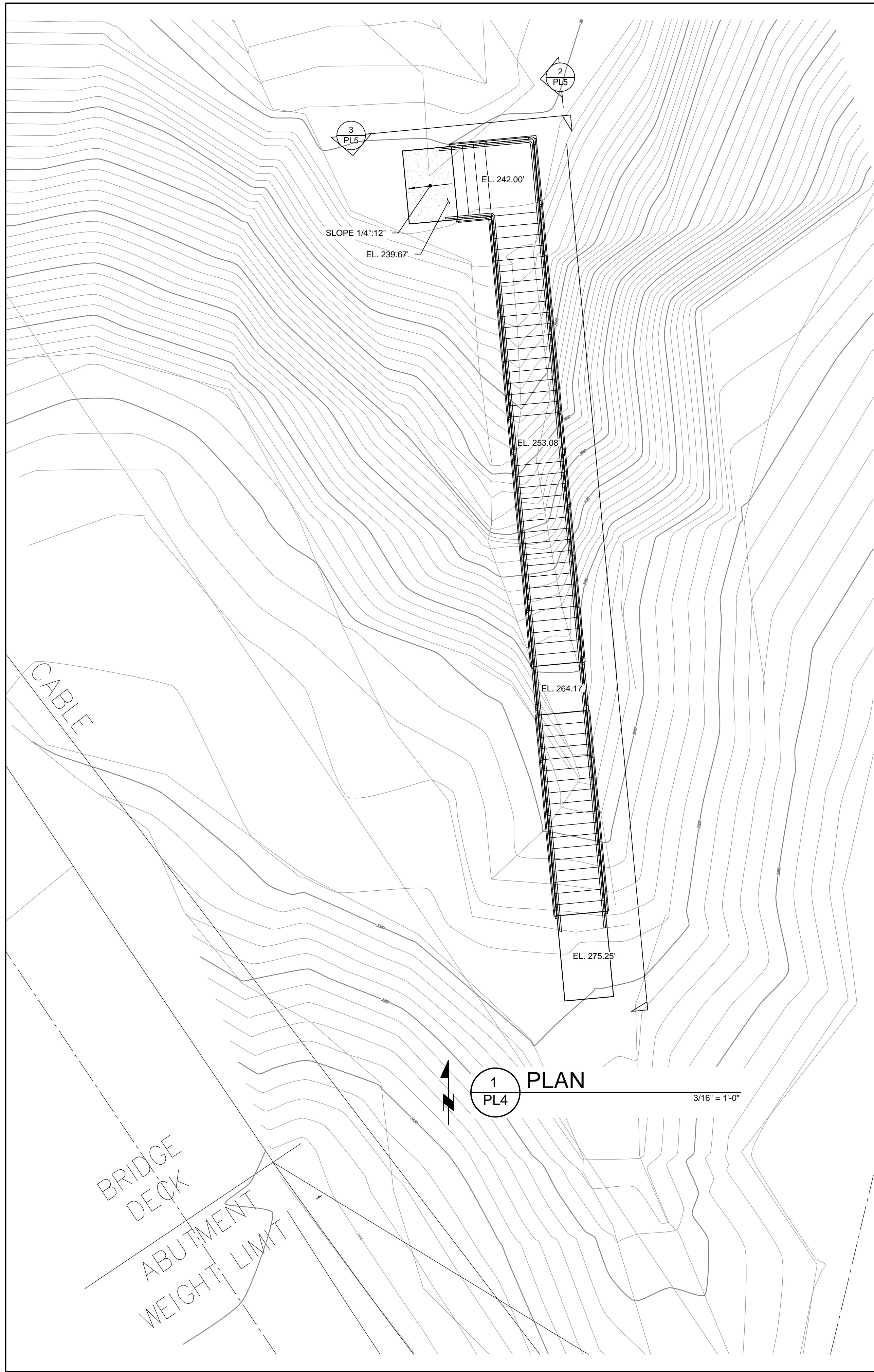

COPYRIGHT 2011  
Miller Consulting Engineers, Inc.

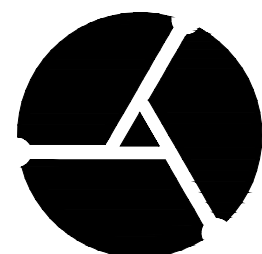

MILLER  
CONSULTING  
ENGINEERS

9570 SW Barbur Blvd.  
Suite One Hundred  
Portland, OR 97219-5412  
Phone (503) 246-1250  
Fax (503) 246-1395  
MCE PROJ. No. 110339

REVISIONS

###  
###  
###  
###  
###

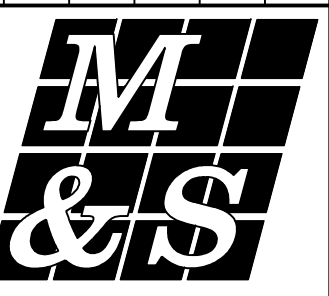

MacKay & Spósito, Inc.  
1325 SE TECH CENTER DRIVE, SUITE 140  
VANCOUVER, WA 98683  
PHONE (360) 695-3411  
FAX (360) 695-0833  
www.mackaysposito.com

PRELIMINARY

Date: MAY 2011  
Scale: 3/16" = 1'-0"  
Designed By:  
Drawn By: BCH  
Checked By:

IMPROVEMENT PLANS  
YALE BRIDGE NON-MOTORIZED BOAT LAUNCH  
EXISTING CONDITIONS PLAN  
CLARK COUNTY, WASHINGTON

M&S PROJECT # 15313

SHEET  
PL4

SHEET # 04 of

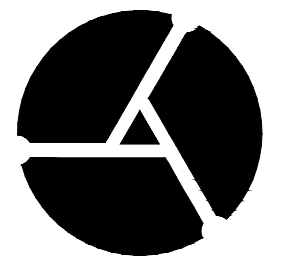

MILLER  
CONSULTING  
ENGINEERS

9570 SW Barber Blvd.  
Suite One Hundred  
Portland, OR 97219-5412  
Phone (503) 246-1250  
Fax (503) 246-1395  
MCE PROJ. No. 110339

REVISIONS

###  
###  
###  
###  
###



MacKay & Sposito, Inc.  
1325 SE TECH CENTER DRIVE, SUITE 140  
VANCOUVER, WA 98683  
PHONE (360) 695-3411  
FAX (360) 695-0833  
www.mackaysposito.com

PRELIMINARY

Date: MAY 2011  
Scale: VARIES  
Designed By:  
Drawn By: BCH  
Checked By:

IMPROVEMENT PLANS  
YALE BRIDGE NON-MOTORIZED BOAT LAUNCH  
EXISTING CONDITIONS PLAN  
CLARK COUNTY, WASHINGTON

M&S PROJECT # 15313

SHEET  
PL5

SHEET # 05 of

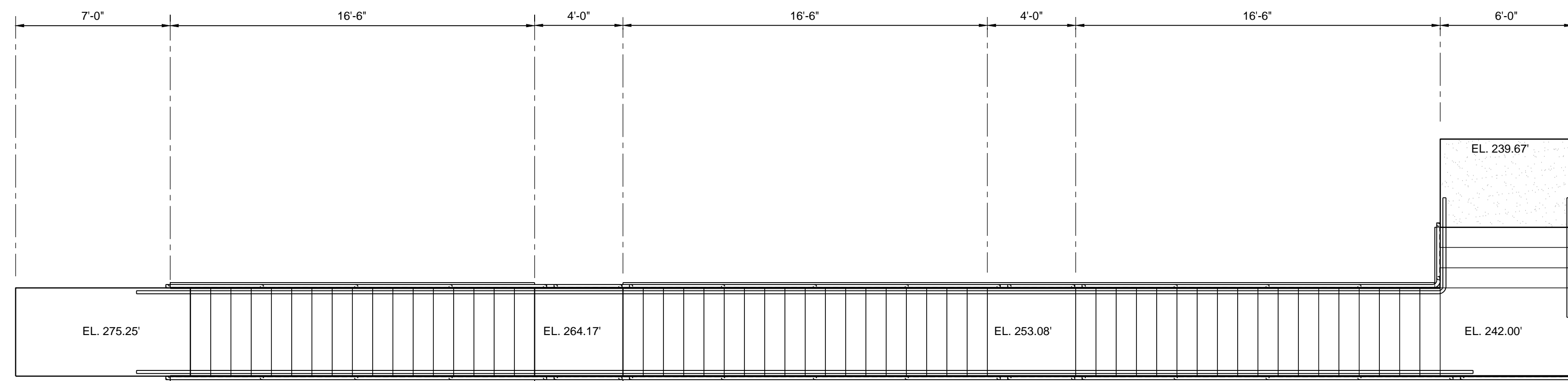

1 STAIR PLAN VIEW  
PL5  
1/4" = 1'-0"

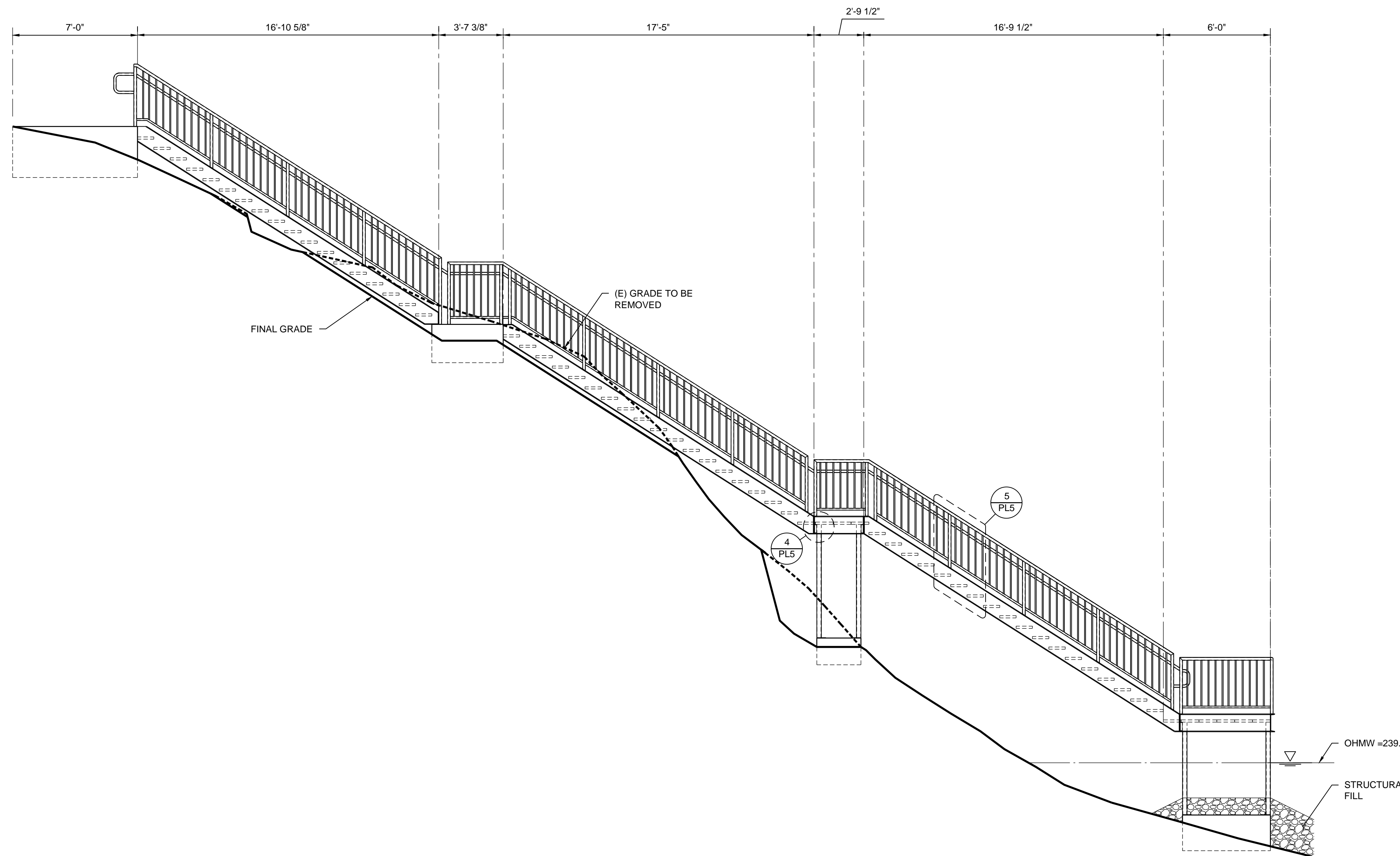

2 STAIR ELEVATION  
PL5  
1/4" = 1'-0"

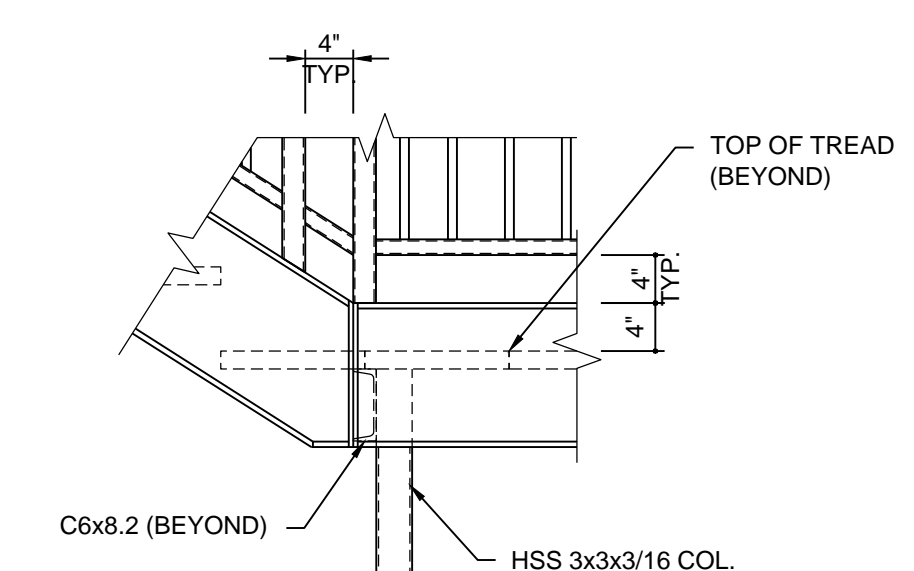

4 LANDING DETAIL  
PL5  
3/4" = 1'-0"

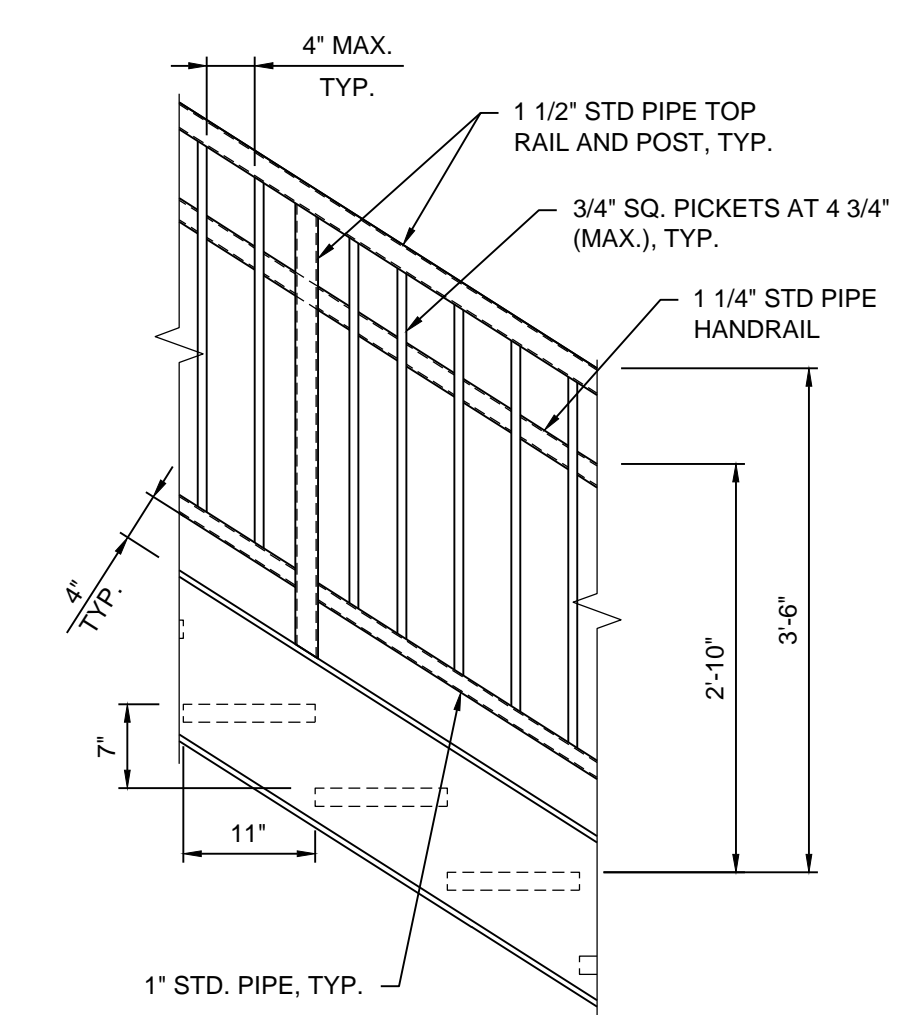
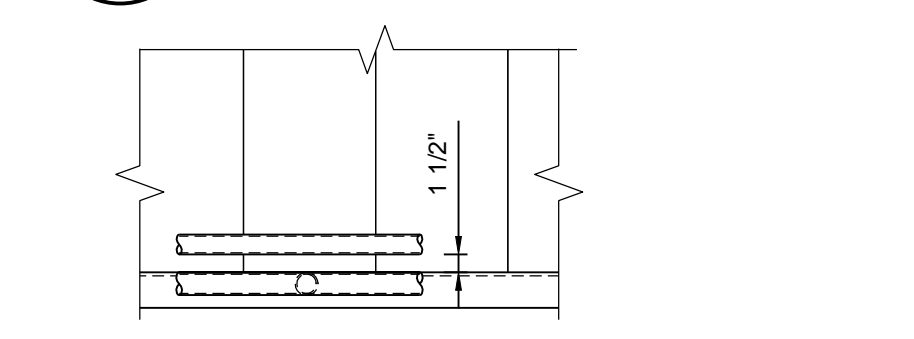

5 GUARDRAIL DETAIL  
PL5  
3/4" = 1'-0"

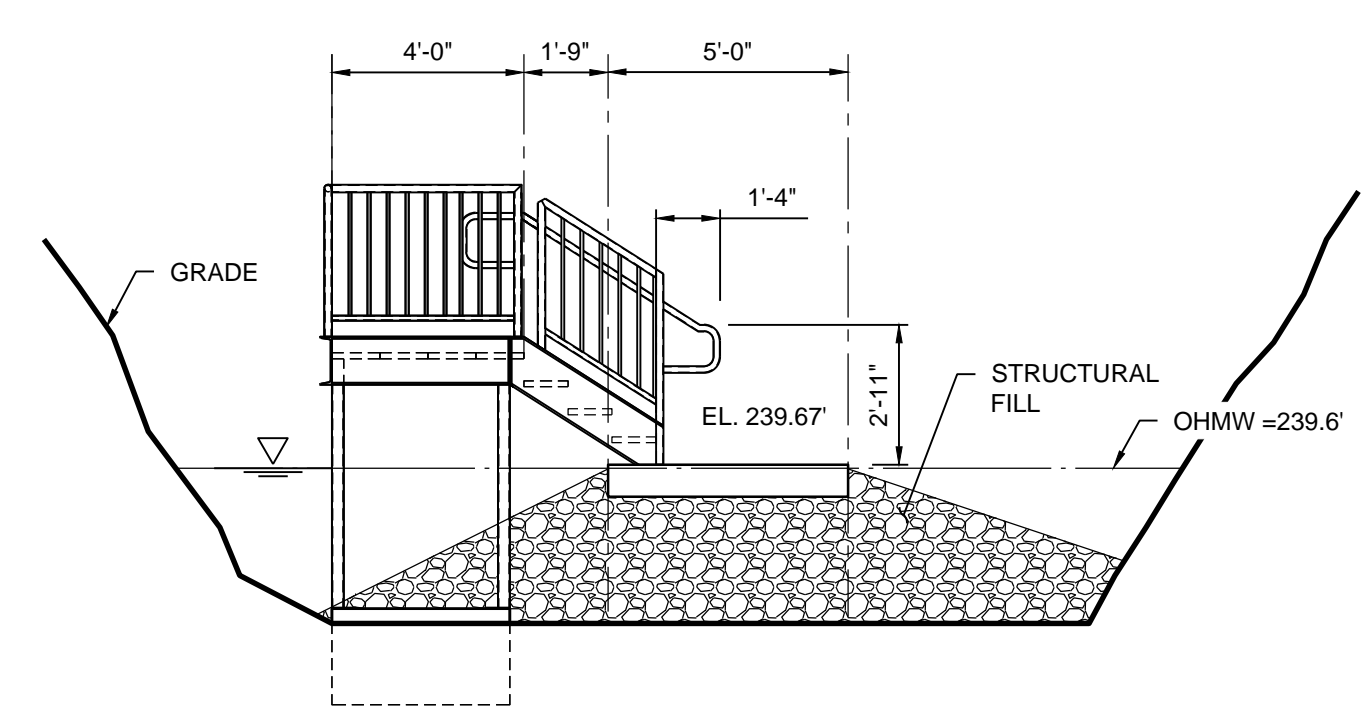

3 STAIR ELEVATION  
PL5  
1/4" = 1'-0"

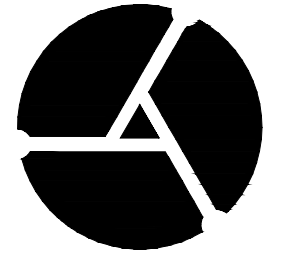

MILLER  
CONSULTING  
ENGINEERS

9570 SW Barbur Blvd.  
Suite One Hundred  
Portland, OR 97219-5412  
Phone (503) 246-1250  
Fax (503) 246-1395  
MCE PROJ. No. 110339

REVISIONS

###  
###  
###  
###  
###

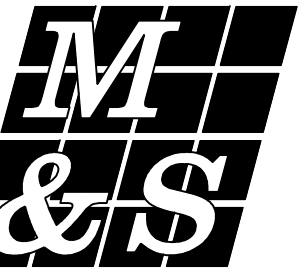

MacKay & Sposito, Inc.  
1325 SE TECH CENTER DRIVE, SUITE 140  
VANCOUVER, WA 98683  
PHONE (360) 695-3411  
FAX (360) 695-0833  
www.mackaysposito.com

PRELIMINARY

Date: MAY 2011  
Scale: 3/8" = 1'-0"  
Designed By:  
Drawn By: BCH  
Checked By:

IMPROVEMENT PLANS  
YALE BRIDGE NON-MOTORIZED BOAT LAUNCH  
EXISTING CONDITIONS PLAN  
CLARK COUNTY, WASHINGTON

M&S PROJECT # 15313

SHEET  
PL6

SHEET # 06 of

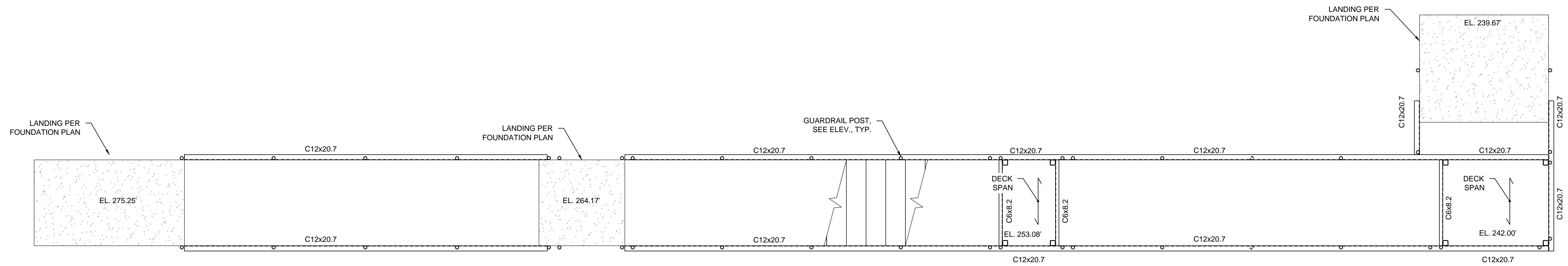

1  
PL6  
FRAMING PLAN  
3/8" = 1'-0"