

TABLE OF CONTENTS

4.5 ENGINEERING FEASIBILITY OF FISH PASSAGE FACILITIES (AQU 5)	AQU 5-1
4.5.1 Study Objectives	AQU 5-1
4.5.2 Study Area	AQU 5-1
4.5.3 Methods	AQU 5-1
4.5.4 Key Questions.....	AQU 5-7
4.5.5 Results.....	AQU 5-8
4.5.6 Schedule.....	AQU 5-18
4.5.7 References.....	AQU 5-18
4.5.8 Comments and Responses on Draft Report	AQU 5-19

AQU 5 Appendix 1 Engineering Feasibility Study for Fish Passage Facilities: Phase Two

LIST OF TABLES

Table 4.5-1. Fish Passage Study schedule.	AQU 5-18
--	----------

LIST OF FIGURES

Figure 4.5-1. System 1: Volitional passage with criteria screens.	AQU 5-11
Figure 4.5-2. System 2: Volitional passage with surface collectors.	AQU 5-12
Figure 4.5-3. System 3: Fish lifts upstream, surface collectors downstream.	AQU 5-13
Figure 4.5-4. System 4: Fish lifts upstream, surface collectors downstream with trucking facilities.....	AQU 5-14
Figure 4.5-5. System 5: Trap-and-haul to upper Swift with surface collectors (bypass Merwin and Yale).	AQU 5-15
Figure 4.5-6. System 6: Trap-and-haul to upper Swift with screens (bypass Merwin and Yale).....	AQU 5-16
Figure 4.5-7. System 7: Resident trap-and-haul (no anadromous reintroduction).	AQU 5-17

This page intentionally blank.

4.5 ENGINEERING FEASIBILITY OF FISH PASSAGE FACILITIES (AQU 5)

4.5.1 Study Objectives

The objectives of the Engineering Feasibility of Fish Passage Facilities investigations include:

- Determine the engineering feasibility of constructing both upstream and downstream fish passage facilities at the Lewis River Hydroelectric Projects.
- Determine or estimate the biological effectiveness of each upstream and downstream fish passage facility examined, and quantify the unknowns surrounding each facility component. Analysis of biological effectiveness will focus primarily on anadromous salmonids.
- Combine feasible facilities into fish passage systems that are both biologically effective and capable of meeting the range of fish management objectives being developed by the Aquatic Resources Group (ARG).
- Determine or estimate the biological effectiveness of each upstream and downstream fish passage system examined. Analysis of biological effectiveness will focus primarily on anadromous salmonids.
- Quantify the unknowns or additional data necessary to make informed decisions about fish passage system alternatives.
- Identify and describe the impacts of proposed facilities on water quality, power production, reservoir operations, and other overall project components.
- Provide planning level cost estimates and identify key cost components (such as constructability issues) to assist in comparing fish passage alternatives.

4.5.2 Study Area

The study area includes the primary project facilities at Merwin, Yale, Swift No. 1 and Swift No. 2.

4.5.3 Methods

The Engineering Feasibility Study for Fish Passage Facilities will be conducted in 6 tasks, as described below. It should be noted that Task 1 has already been completed. The remaining tasks will not begin until April of 2000. Additional information on the proposed schedule is provided in the Study Costs and Schedule Section.

Task 1 – Initial Brainstorming Meeting (completed)

A brainstorming meeting to discuss Lewis River fish passage issues was held on August 3, 1999. At this meeting, ARG members developed a list of candidate species that would

benefit from migration and access to stream habitat currently blocked by project structures. A summary of the candidate species discussed at the August 3 meeting is provided the table below.

Species	Species
Bull Trout	Early Coho (Natural)
Wild Steelhead	Sea-run Cutthroat Trout
Spring Chinook (Natural)	Kokanee
Native Resident Fish Species	

Task 2 – Compilation of Pre-Design Information

Prior to commencing with the conceptual design phase of the study, project information will be compiled and organized for use in the development of fish passage facilities. This information will include project physical characteristics (simplified drawings illustrating general layout, dimensions and elevations), project operating characteristics and constraints, flow data (extreme minimums, 10% exceedence, 90% exceedence, and flood flows expected by month), and biological data (species, run timing, etc.).

Estimates of the total number of adults and juveniles that may use the facilities must be developed to size some fish passage facilities. Adult run size estimates will be developed using historical Merwin Dam counts of adult migrants. The adult run-size information, and egg-to-smolt survival data found in the literature for each species, will be used to estimate resulting juvenile production.

Additionally, a limited literature review will be conducted to compile a list of references for applicable fish passage technology.

Task 3 – Initial Design Meeting

Following the completion of Task 2, a meeting will be held with the Licensees', agency fisheries engineers and the ARG to develop a range of fish passage facilities to be examined. The recent fish passage reports developed for the Cowlitz River Project (Tacoma Power 1999) will be used to assist meeting attendees in identifying passage facilities that may be effective at the Lewis River Projects. The Cowlitz reports were selected for review because of the similarity between the two basins with regard to dam structures (dam height, reservoir size, turbine depth), river flow, species present, and other environmental conditions (temperature, flood timing etc.).

At this meeting, project consultants will:

- Summarize project characteristics and engineering criteria to be used in the design of both upstream and downstream fish passage facilities (drawings, flows, operational considerations, etc.).

- Present a draft of the biological criteria to be used in the design of both upstream and downstream fish passage facilities, and agree on the final criteria (species, run timing, run sizes, behavioral characteristics, relevant unknowns, etc.).
- Present a preliminary list of fish passage facilities to be examined at each project.
- Describe the approach on how the proposed individual passage facility components will be combined to form functioning fish passage systems for the basin.
- Provide examples (engineering drawings, past reports) of the level of detail that will be provided for each facility and system.
- Communicate the study schedule, and solicit input on the proposed process and individual technical details.

The product of this meeting will be development of a Meeting Summary Report, which will document ARG comments and agreement on the design criteria and fish passage facilities to be examined at each project. This report will be distributed for comment and finalized for the record with comments incorporated or exceptions noted. Consultant staff will use this report as the foundation for writing the Draft Fish Passage Feasibility Report described under Task 4.

Task 4 – Draft Fish Passage Facility Feasibility Study

Based on input received through Task 3, consultant engineers and biologists will produce a feasibility report describing alternatives for potential fish passage facilities and systems. A system is defined as the combination of fish passage facility components needed to meet fish management objectives (e.g., re-introduction of anadromous species, bull trout protection).

The report will include a description of existing project structures, design criteria, flows and operations as developed in Task 2. Proposed fish passage facilities will be described in sufficient detail to define and confirm feasible hydraulic designs, flow requirements, structural feasibility and major construction issues; primarily from an engineering perspective. The effects that each facility has on existing project structures, water quality, power production, reservoir operations, and other environmental attributes will also be characterized. An analysis of the expected performance of each component from a biological perspective will be presented, and critical unknowns and uncertainties will be noted. Planning level cost estimates for each component and system will be presented to assist in comparison of alternatives, and to gain an understanding of the order of magnitude costs necessary to implement various alternatives.

A brief description of each report section and inherent methodologies is presented below.

Executive Summary

An executive summary will be developed summarizing report highlights.

Section 1 – Introduction. A description of the study objectives, coordination with other studies, and an introduction to the study layout will be summarized in this section.

Section 2 – Existing Information. This section will summarize the existing project information for each site, organized under the following headings: project configuration, flow data, hydraulic flow patterns in reservoir/forebay and tailrace, and operational characteristics. Additional details regarding this section are described under Tasks 2 and 3.

Section 3 – Design Criteria. The design criteria utilized in developing conceptual engineering designs will be summarized and divided into three categories as follows: (1) biological; (2) engineering; and (3) the interrelationship between run timing, project flow needs; and basin flows.

Biological criteria will include a list of target species, associated run timing, and estimate of existing and projected run sizes. Behavioral characteristics will be noted where documented for specific projects, or based on general professional opinions.

Engineering criteria will include flow and hydrologic data, operational requirements, and specific criteria to be used in the design and evaluation of the fish passage facility components and systems. Specific criteria will include those developed in conjunction with the ARG, fish facility engineers, and biologists through Task 3, and published references including sources available at the following web sites:

National Marine Fisheries Service: www.nwr.noaa.gov

Washington Department of Fish and Wildlife: www.wa.gov/wdfw/hab/-engineer/fishscrn.htm

The criteria used for designing high velocity juvenile screening facilities can be found in USACE (1998).

Adult passage criteria will be developed based on published criteria (Bates 1992), and in consultation with agency fisheries engineers and the ARG at the Initial Design Meeting.

Section 4 – Upstream Passage Facilities. The specific type and number of facilities to be evaluated will be developed by the consultant team in conjunction with the ARG through Task 3, and based on preliminary concept development. At this time, it is envisioned that the following concepts will be examined for upstream fish passage facilities:

- Upstream collection facilities (entrance size, location, configuration, need for barrier dam, diversion facilities, etc.);
- Transport facilities (ladders, trap & transport via truck, via tram, etc., release sites, etc.); and
- Other concepts developed through consultation with the ARG.

Section 5 – Downstream Passage Facilities. Similar to Section 4, the final number and type of facilities to be evaluated for downstream passage will be developed by the consultant team in conjunction with the ARG through Task 3. Downstream fish passage facilities anticipated to be examined in the report include:

- Exclusionary or partial exclusionary screens (travelling, stationary, in-turbine, in-penstock, intake, etc.);
- Surface attraction and collection concepts (high flow, low flow, location, entrance location and configuration, enhancement techniques, etc.);
- Use of tributary traps;
- Collection and haul opportunities and techniques;
- Use of juvenile sorting, sampling, and marking facilities; and
- Other concepts developed in conjunction with the ARG.

Section 6 – Fish Passage System Development. Fish passage systems will be developed based on combinations of individual passage components. Potential systems will be designed that integrate both upstream and downstream passage for one or more of the following basin passage objectives:

- Allow adult anadromous fish access upstream of Merwin Dam;
- Allow juvenile anadromous fish passage downstream of Swift Dam;
- Allow adult resident fish access to all river reaches and reservoirs;
- Allow juvenile resident fish passage downstream of Swift dam; and,
- Other objectives developed in conjunction with the ARG.

Precisely how the facilities are combined into functional systems will be determined by consultant engineers and biologists through consultation with the ARG, agency fish engineers and the Steering Committee.

Section 7 – Pros and Cons Analysis. The biological and engineering pros, cons, impacts on other project components and systems, and uncertainties associated with each alternative will be presented. It is recognized that this task can be subjective; therefore, every attempt will be made to present this summary in a format to facilitate ease of review and discussion. Opinions versus fact will be clearly identified as appropriate.

Estimates of adult and juvenile survival rates through each structure and system will be developed based on site-specific data (if available), the results obtained from functioning facilities in other basins, and professional judgment. Impacts of fish passage facilities on resident fish (bull trout, kokanee) will be included in the biological analysis.

Section 8 – Recommendations for Additional Data Collection. Based on the unknowns and data needs identified in Section 7, preliminary recommendations to advance the existing knowledge base where necessary will be developed and presented to facilitate discussion. Data and research needs and recommendations may include hydraulic and/or numerical modeling, and biological testing that would assist in advancing the conceptual designs or confirming biological effectiveness of alternatives.

Section 9 – Costs. Planning level “engineers estimates of probable construction costs” will be developed for each facility and overall system alternative. These estimates will be based on quantity take-offs developed from the conceptual designs, and cost data published and maintained in consultant databases of fish facility projects. Where possible, input from agency fisheries engineers and actual construction costs associated with similar facilities in other basins will be used to “ground-truth” the cost estimates. The costs associated with any proposed prototype facility will also be developed and presented.

Task 5 – Draft Fish Passage Facility Feasibility Report

The Draft Fish Passage Feasibility Report will be distributed to all ARG members for review and comment. A meeting to discuss study results will be held approximately 30 days after the report submittal. The purpose of this meeting will be to critique and discuss the draft report, discuss the stated design criteria, obtain technical input to “fine-tune” facility and system designs, review and discuss conclusions regarding the biological effectiveness and analysis, identify and discuss additional data or testing needs, and to facilitate collection of comments on the report. Following this meeting, ARG members will be expected to submit written comments identifying points of technical agreement or disagreement with the draft report.

Task 6 – Final Fish Passage Feasibility Report

Comments obtained following the review meeting in Task 5 will be reviewed, and the report will be edited to reflect changes agreed to by ARG members. Depending on the nature of the comments received, a second meeting may be required to gain consensus on all of the issues.

The final Fish Passage Feasibility Report will be completed 90 days prior to the submittal of the Preliminary Draft Resource Enhancement Alternatives Document (READ) as described in the Study Costs and Schedule section. The report will describe fish passage facilities and systems proposed for each alternative, which will ultimately be examined in the APEA. The data presented in the Fish Passage Feasibility Report will be used as input to the APEA to analyze fish facility effectiveness, biological impacts, costs, affects on project operations, power production, recreation, water quality, wildlife, cultural resources, and other project components.

4.5.4 Key Questions

Results of the Fish Passage Study can be used to address some of the following “key” watershed questions identified during the Lewis River Cooperative Watershed Studies meetings:

- What types of reintroduction methods might be successful in the Lewis River watershed and what is the potential cost and engineering feasibility of each of these methods (e.g., trapping and hauling, construction of fishways, screening, stocking of fry, planting of eggs)?

This study provides answers related to the potential costs and engineering feasibility of constructing facilities to meet various biologically led reintroduction goals.

- What types of fish screens would be needed or desirable if fish passage were constructed?

This study provides answers to this question.

- What physical, chemical, and biological conditions currently exist in project reservoirs or stream habitats that may affect anadromous fish movements and migrations and how might potential impacts resulting from these conditions be reduced?

This study addresses physical conditions in the system such as the existing dams, reservoir fluctuation, existing fish facilities, etc. Chemical and biological conditions will be addressed in other studies.

- What are the characteristics of the velocity profiles currently existing in reservoirs and how would these characteristics potentially affect movement and migration of anadromous salmonids through project reservoirs (e.g., travel time, spatial and temporal patterns of downstream migration)?

This study does not address these questions directly, but available data is referenced.

- What types of flow management alternatives (bypass flows, ramping rates, operational rule curve modifications, etc.) might increase the potential success of anadromous fish reintroduction efforts?

This study does not address these questions directly, but considers results from related studies such as AQU 2, AQU 3, the operations model being developed by PacifiCorp, flood management studies (FLD 1), and references any operational changes that may be beneficial to specific fish passage facilities.

- What types of reservoir management alternatives might increase the potential success of anadromous fish reintroduction efforts (e.g., reservoir drawdown to facilitate downstream migration of smolts)?

This study does not directly address this question, except as appropriate to specific fish passage facilities.

- How do reservoir water level fluctuations affect aquatic and riparian connectivity?

The Speelyai connectivity study (AQU 9), the Swift Bypass Reach Synthesis Study (WTS 4), and the Reservoir Fluctuation Study (TER 6) address this question.

- What effects would reintroduction measures have on wild or native stocks (e.g., handling and sorting of fish to select suitable stocks for reintroduction, etc.)?

This study does not address this question, other than to communicate capabilities and limitations of identified sorting facilities.

4.5.5 Results

In late 2000, the ARG began to identify which fish passage facilities and systems would be explored and developed at each of the Lewis River projects. As a starting point for these discussions, 5 theoretical basin plans were developed and presented graphically, along with biological criteria. Each basin plan identified a group of individual fish passage “facilities” necessary to complete a fish passage “system” that would achieve the basin plan biological goals.

The Engineering Feasibility Study for Fish Passage Facilities, Draft–Phase 1 Report (PacifiCorp and Cowlitz PUD 2001) was developed during the first half of 2001 and distributed to the ARG on July 26, 2001. The report identified the 5 potential systems and fish passage facility alternatives to meet the system goals. The system goals are defined as:

- Reconnect fish habitat and fish populations throughout the Lewis River basin.
- Reintroduce anadromous salmon into the upper Lewis River basin.
- Protect and enhance bull trout populations.

The 5 potential fish passage systems addressed in the Draft Fish Passage Facility Feasibility Report were:

- System 1: Maximize Fish Habitat and Population Connectivity – Volitional. This system relies on volitional adult and juvenile fish passage facilities to reconnect fish habitat and populations throughout the upper Lewis River basin. This system is designed to achieve all 3 basin goals.
- System 2: Maximize Fish Habitat and Population Connectivity – Trap-and-haul. The approach is similar to System 1 except that trap-and-haul facilities are used in place of volitional facilities.

- System 3: Anadromous Reintroduction Program – Upper Basin Emphasis. System 3 focuses on achieving the goal of reintroducing anadromous fish to the upper Lewis River basin (above Swift Reservoir).
- System 4: Reconnect and Protect the Swift and Yale Bull Trout Populations. The objective of System 4 is to meet the basin goal of protecting bull trout populations within and above the Lewis River Projects. The approach assumes that connecting the Yale and Swift bull trout populations and reducing entrainment mortality best achieves protection for bull trout. This approach will not achieve the anadromous reintroduction goal.
- System 5: Isolate and Protect the Yale and Swift Bull Trout Populations. This option is similar to System 4 except that the 2 bull trout populations remain isolated (i.e. minimal interaction). This approach will not achieve the anadromous reintroduction goal.

On September 10, 2001, WDFW provided comments on the Draft Phase 1 Report. These and other comments offered during ARG meetings were considered in refinements to facility and system concepts, and are presented in the Phase 2 Report. This report is included as AQU 5 Appendix 1.

A comparison of the Resource Enhancement Alternatives Document (READ) aquatics actions and the Draft Phase 1 System Alternatives was also performed to ensure the fish passage actions stated in the READ document are addressed.

As a result of the WDFW comments, the READ comparison, and the absence of more specific biological system goals, the 5 potential systems have been increased to 7 systems in the Phase 2 Report to address all options discussed by the ARG. The revised fish passage systems are defined as:

- System 1: Volitional Passage with Criteria Screens (Figure 4.5-1). System 1 relies on volitional adult and juvenile fish passage facilities to reconnect fish habitat and populations throughout the upper Lewis River basin. Upstream passage facilities use fish ladders at each dam. Downstream passage facilities use criteria screens with sub-sampling facilities at each dam. This system is designed to achieve all 3 basin goals.
- System 2: Volitional with Surface Collectors (Figure 4.5-2). System 2 relies on volitional adult and juvenile fish passage facilities to reconnect fish habitat and populations throughout the upper Lewis River basin. Upstream passage facilities use fish ladders at each dam. Downstream passage facilities use surface collectors with sub-sampling facilities at each dam. This system is designed to achieve all 3 basin goals.
- System 3: Fish Lifts Upstream, Surface Collectors Downstream (Figure 4.5-3). The approach is similar to System 2 except that upstream fish lift facilities are used in place of fish ladders. This system is designed to achieve all 3 basin goals.
- System 4: Fish Lifts Upstream, Surface Collectors Downstream with Trucking Facilities (Figure 4.5-4). The approach is similar to System 3 except that downstream

fish passage facilities include trucking facilities. This system is designed to achieve all 3 basin goals.

- System 5: Trap-and-Haul to Upper Swift with Surface Collectors (bypass Merwin and Yale) (Figure 4.5-5). The objective of System 5 is to meet the basin goal to reintroduce anadromous salmon into the upper Lewis River basin. This system uses both upstream and downstream trap and haul facilities.
- System 6: Trap-and-Haul to Upper Swift with Screens (bypass Merwin and Yale) (Figure 4.5-6). The approach is similar to System 5 except downstream passage uses screens in place of surface collectors.
- System 7: Resident Trap-and-Haul (no anadromous reintroduction) (Figure 4.5-7). The objective of System 7 is to meet the basin goal to protect and enhance bull trout populations. The approach assumes that connecting the Yale and Swift bull trout populations and reducing entrainment mortality best achieves protection for bull trout. This approach will not achieve the anadromous reintroduction goal.

The Phase 2 Report also includes minor revisions and clarifications on specific design criteria, additional detail on specific fish passage facility conceptual designs, and the 7 fish passage systems referenced above, with planning level cost estimates for each system.

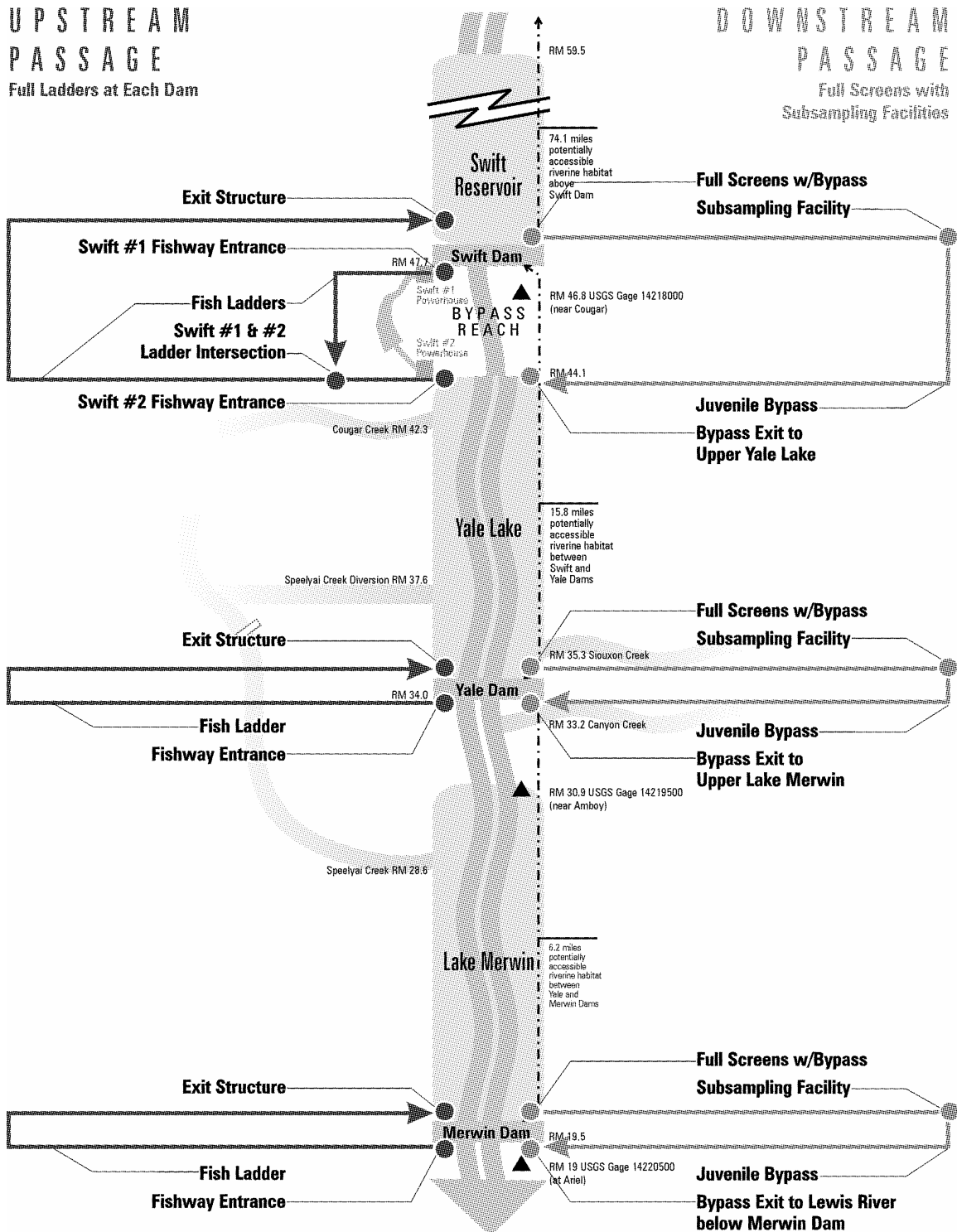

Figure 4.5-1. System 1: Volitional passage with criteria screens.

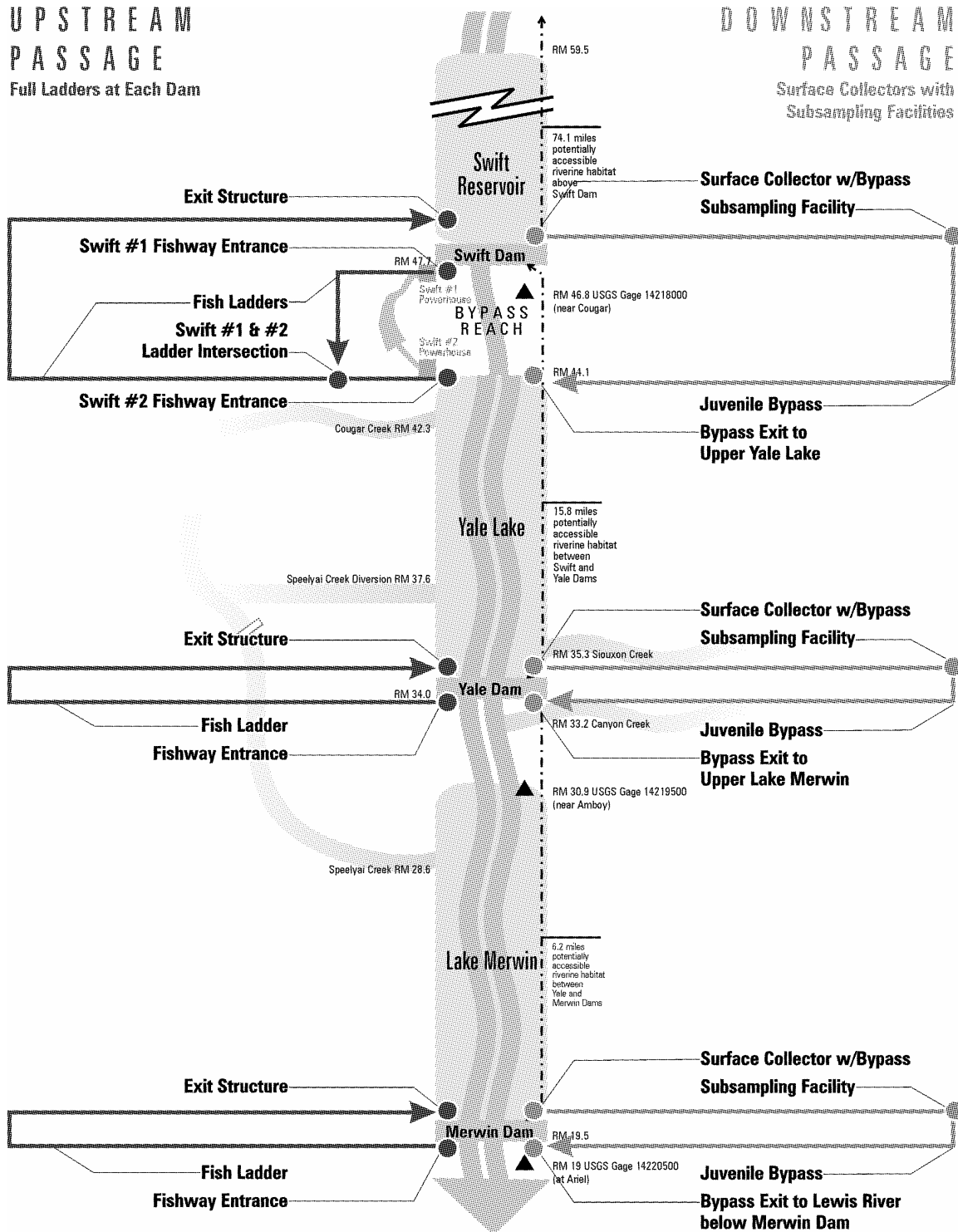

Figure 4.5-2. System 2: Volitional passage with surface collectors.

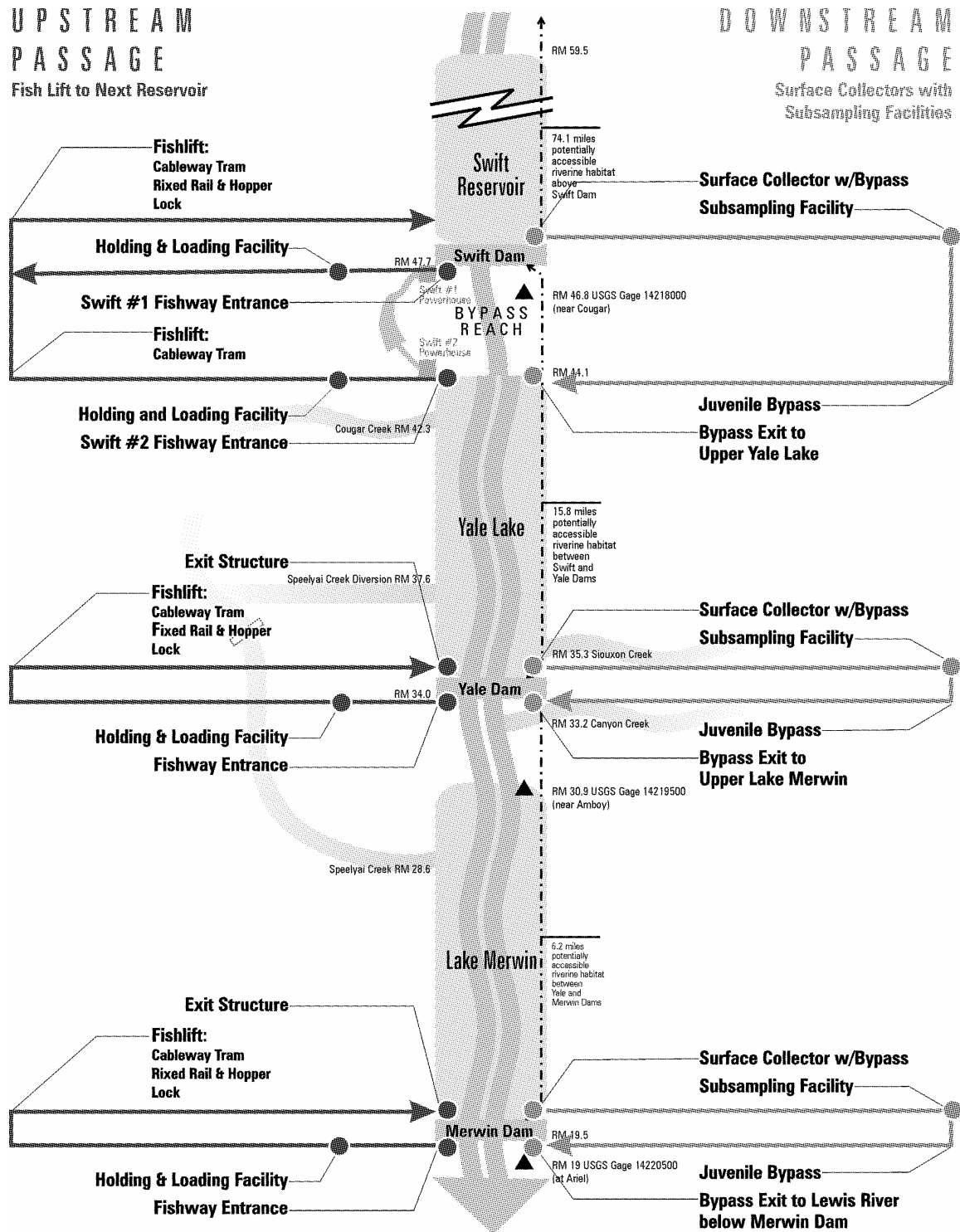

Figure 4.5-3. System 3: Fish lifts upstream, surface collectors downstream.

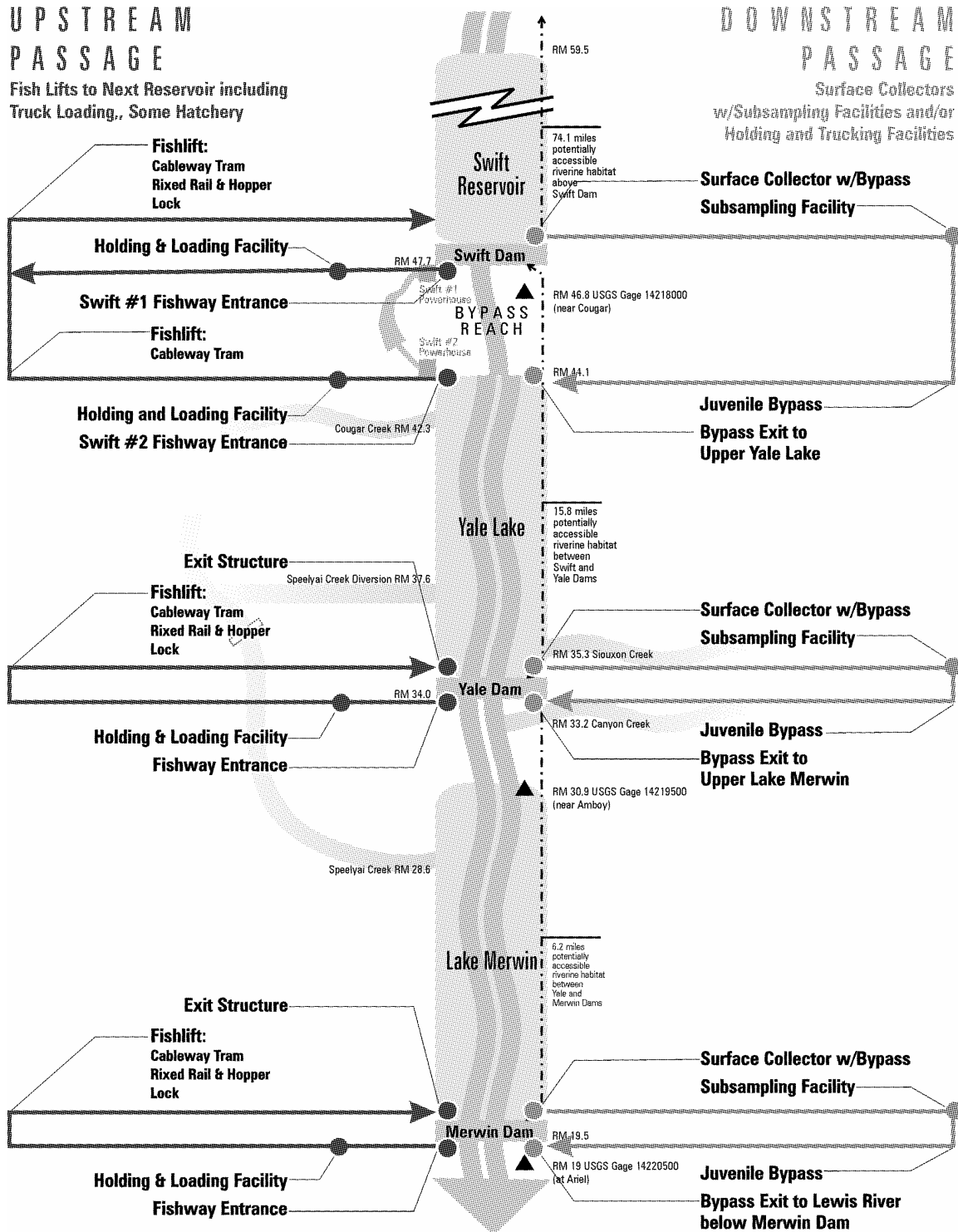

Figure 4.5-4. System 4: Fish lifts upstream, surface collectors downstream with trucking facilities.

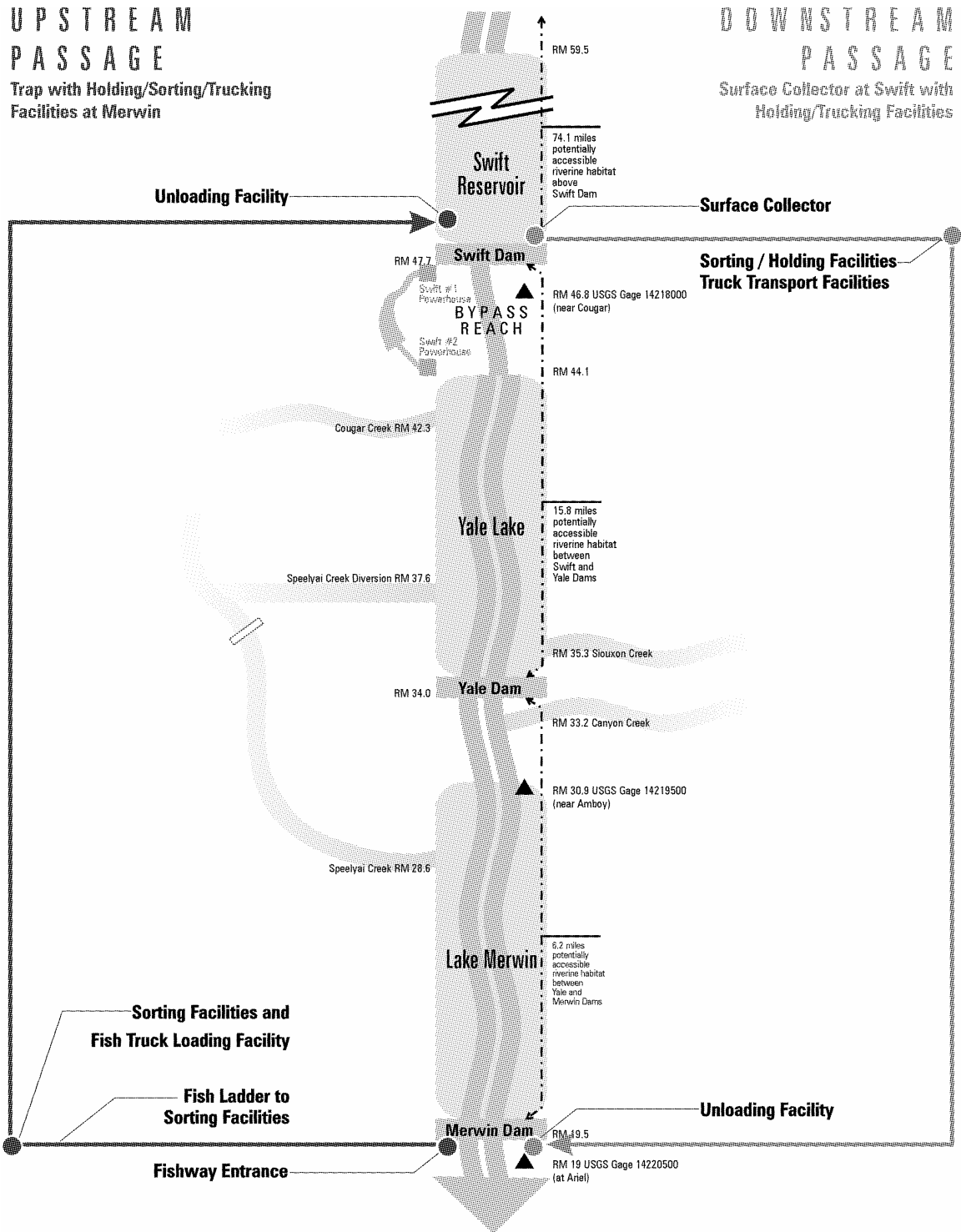

Figure 4.5-5. System 5: Trap-and-haul to upper Swift with surface collectors (bypass Merwin and Yale).

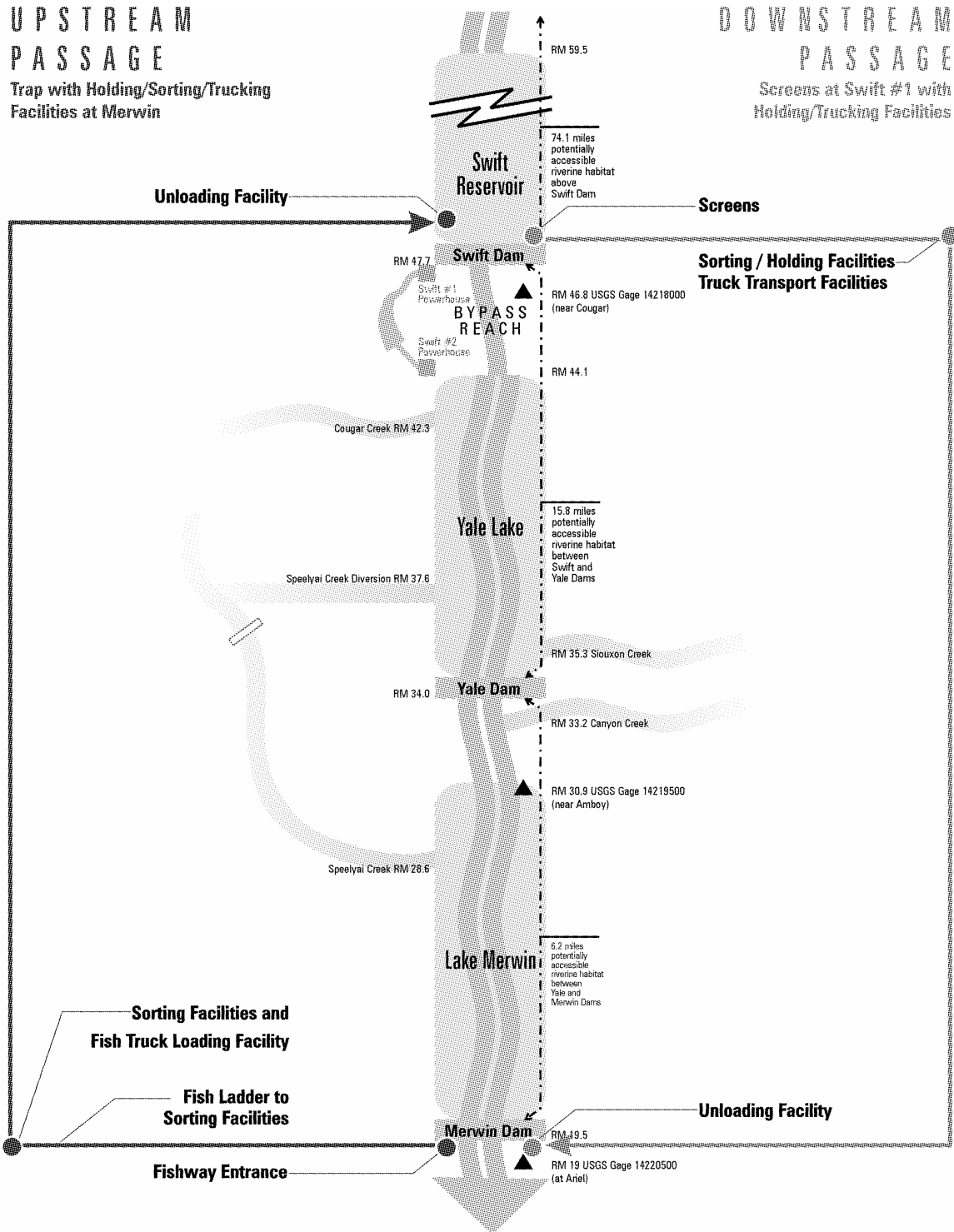

Figure 4.5-6. System 6: Trap-and-haul to upper Swift with screens (bypass Merwin and Yale).

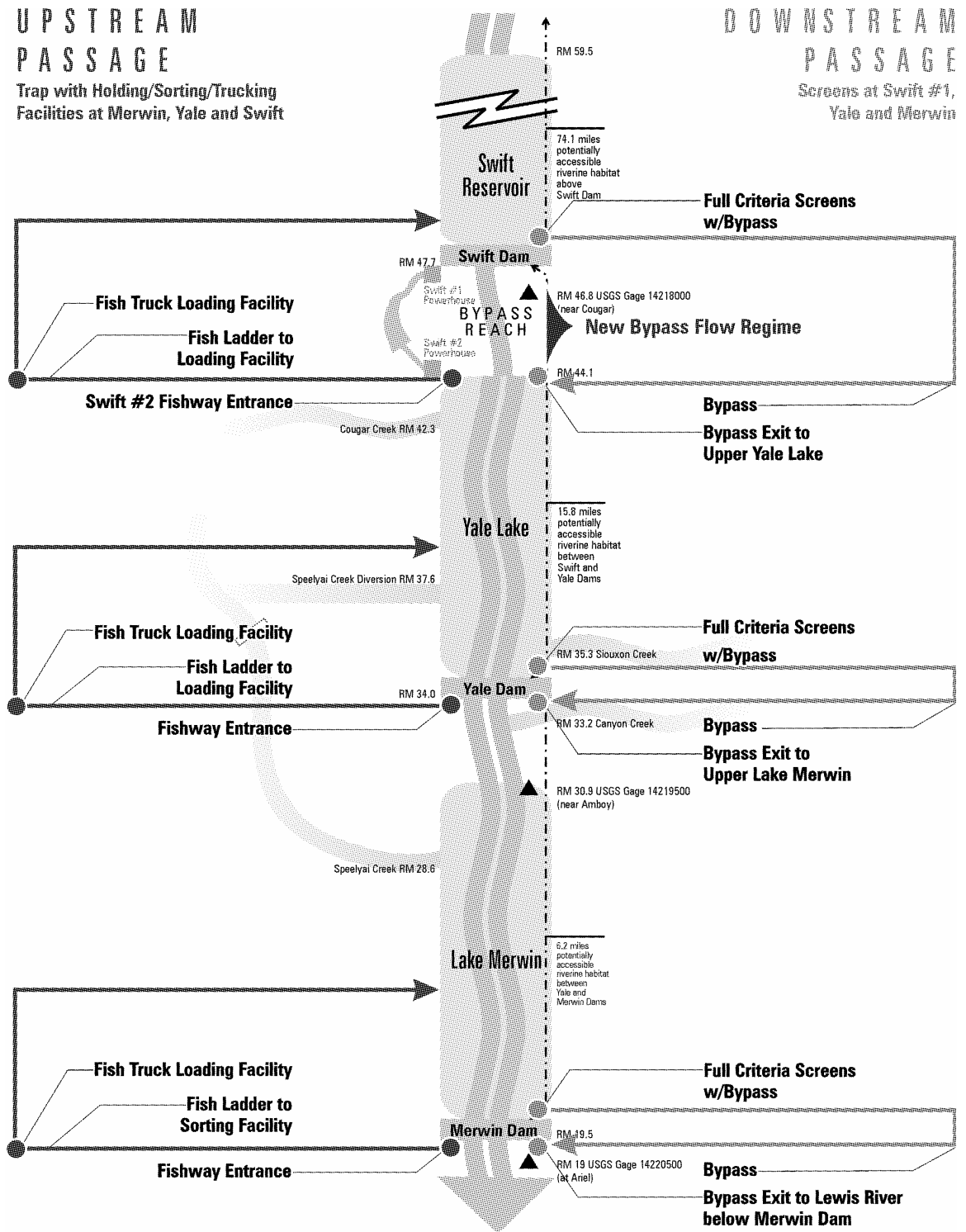

Figure 4.5-7. System 7: Resident trap-and-haul (no anadromous reintroduction).

4.5.6 Schedule

The current schedule for the Fish Passage Feasibility Study is very similar to that presented in the Fish Passage Working Notebook, approved by the ARG at the March 30, 2000 meeting. Schedule highlights are presented in Table 4.5-1.

Table 4.5-1. Fish Passage Study schedule.

Task	Start Date	Finish Date
Compilation of Pre-Design Information (completed)	January 2000	September 2000
Initial Design Meeting (completed)	September 2000	November 2000
Develop Draft Fish Passage Report (completed)	November 2000	June 2001
Distribute Draft Fish Passage Report & Meeting (completed)	July 2001	September 2001
Final Fish Passage Report	September 2001	March 2002

4.5.7 References

Bates. 1992. Fishway Design Guidelines for Pacific Salmon. Presented at US Fish and Wildlife Service's Fish Passageways and Diversion Structures course, June, 1996. Ken Bates. Washington Department of Fish and Wildlife. March 1992.

PacifiCorp and Cowlitz PUD. 1999, as amended. Study Plan Document for the Lewis River Hydroelectric Projects. Portland, OR. and Longview, WA. October 29, 1999 as amended.

PacifiCorp and Cowlitz PUD. 2001. Engineering Feasibility Study for Fish Passage Facilities. Draft - Phase 1 Report. Prepared by Montgomery Watson Harza, Bellevue, WA. July 2001.

Tacoma Power. 1999. The 90% Draft Fish Passage Study. Cowlitz River Hydroelectric Project, (FERC No. 2016). Prepared by Harza Engineering for Tacoma Power. Tacoma, WA.

U.S. Army Corp of Engineers. 1998. Final Report: Bonneville First Powerhouse Juvenile Fish Surface Bypass High Flow Dewatering Facility and Outfall Alternatives Study. Portland District, Contract DCW57-97-D-0007. October 1998.

4.5.8 Comments and Responses on Draft Report

This section presents stakeholder comments provided on the draft report, followed by the Licensees' responses. The final column presents any follow-up comment offered by the stakeholder and in some cases, in italics, a response from the Licensees.

Commenter	Volume	Page/ Paragraph	Statement	Comment	Response	Response to Responses
WDFW - KAREN KLOEMPKEN	1	AQU 05	Upstream.	<p>How does the failure of the Swift Canal affect this study?</p> <p>Why aren't tailrace or draft tube barriers being proposed or costs estimated?</p> <p>Swift No. 2 Canal – Fish wouldn't be purposely introduced into the canal, but they are in the canal and they need to be considered in these discussions.</p>	<p>1. The effect of the Swift failure on these study results is unknown at this time since a decision has yet to be made regarding whether the Swift No. 2 Project is abandoned or rebuilt.</p> <p>2. The Licensees believe MWH makes a good argument for why tailrace barriers are not needed. We have been unable to locate a report for Winchester dam that supposedly documents mortalities from fish entering draft tubes, and have not found any other studies that document draft tube mortalities. On the other hand there have been two recent studies that have shown that steelhead and salmon do not attempt to swim up draft tubes that are by far much more accessible than the project draft tubes on the Lewis (studies conducted on Powerdale on Hood River and the Oak</p>	

Commenter	Volume	Page/ Paragraph	Statement	Comment	Response	Response to Responses
					Grove project on the Clackamas in Oregon.) We do not believe the evidence exists that points to the need for tailrace barriers which is why we have not requested that MWH study the feasibility. 3. Downstream passage facilities have not been proposed at Swift No. 2 because it is expected that the passage system proposed at Swift No.1 would protect migrating fish stocks.	
WDFW – JIM BYRNE	1	AQU 05	Fish Passage.	This has been most disappointing because it provides no passage design or plans just lists the basic concepts and options. It seems to only partially answer the first of the Objectives; yes it is feasible to provide passage. Objectives 2-7 are not answered or only partially answered.	More engineering design detail was presented in the Phase 2 Fish Passage Report distributed to all ARG members in April 2002. This Phase 2 report is included in Volume 5 as AQU 5 Appendix 1.	
WDFW – JIM BYRNE	1	AQU 05	Key questions.	Only Key questions 1 & 3 were partially answered.	The study was not designed to address all of the key questions listed. This is explained on page 5-2.	There were 8 key questions only two were partially answered. There is no explanation other than the study will address some key questions. Licensees' Response: <i>The "key questions" were developed in the Watershed Planning Process that preceded</i>

Commenter	Volume	Page/ Paragraph	Statement	Comment	Response	Response to Responses
						<p><i>development of project study plans. Questions that had any relationship to fish passage were identified in the study plan, despite the fact that the study was not designed to address all of them. The intent of the fish passage study was to define potential facilities, determine their feasibility, and estimate their costs. The biological components were or are being addressed by other studies. To summarize Section 4.5.4, Key Questions (Q) 1 and 3 addressed the fish passage components, not biological components. Q 2 was answered. The study was not designed to address reservoir water velocities in Q 4. Other studies answered Q5. Q 6 is indirectly related to fish passage, and was addressed to that extent. Q 7 is not directly related to fish passage facilities. Q 8 is primarily a biological question.</i></p>
TWHB	1	AQU 05-1	Task 1	Does not include Lamprey	Comment noted.	<p>Verbal comments were provided to Frank Shrier (PacifiCorp) at the 10/1/02 ARG meeting. Mr. Backman requested more detail than the response provided.</p>

Commenter	Volume	Page/ Paragraph	Statement	Comment	Response	Response to Responses
						Licensees' Response: <i>The conceptual fish passage designs do not specifically address lamprey. Final design very likely will evaluate lamprey passage requirements.</i>
USDA Forest Service: John Kinney	1	AQU 05-1 Objective 3	...range of fish management objectives...	<p>Until the recent introduction of the new and improved "Framework" that incorporates all relevant policies etc and information, I'm not sure whether objective 3 would have been met. For that matter, I'm unsure what "range of fish management objectives" the study is referring to considering the proponents position relative to fish management?</p> <p>The Fish Caucus has submitted a proposed revision on the Framework to the proponents (21 June 02). We have received a proponent revised AQU-18 to be discussed on 15 July 02.</p>	This study (AQU 5) was published before the "framework" referenced by the commenter began to evolve. If, as indicated, a framework is developed through a new study (AQU 18), results will be reported when that investigation is complete.	
USDA Forest Service: John Kinney	1	AQU 05-1 Objective 4	Determine or estimate the biological effectiveness...	Objective 4 implies a broader biological emphasis that would take into account Pacific lamprey, white sturgeon, and other biota. Language found in the "Framework" needs to be consistent with earlier documents.	The report will be changed to reflect that biological effectiveness refers primarily to anadromous salmonids.	We would advocate inclusion of the historical fish assemblage when addressing the Lewis River below, within, and above the projects.
TWHB	1	AQU 05-2	Run size	Needs to be re-evaluated	Comment noted.	Verbal comments were provided to Frank Shrier (PacifiCorp) at the 10/1/02 ARG meeting. Mr. Backman

Commenter	Volume	Page/ Paragraph	Statement	Comment	Response	Response to Responses
						<p>requested more detail that the response provided.</p> <p>Licensees' Response: <i>The question targets historic run sizes. The best information we have is from WDF (1951) and has been included in AQU 1.</i></p>
WDFW – JIM BYRNE	1	AQU 05-2	Answer to questions.	Answers to question 1 provided no cost estimates and question 3 provided no chemical or biological conditions as specified.	Table 6.3-1 in Volume 5, AQU 5 Appendix 1 provides cost estimates for seven fish passage systems. The study was not designed to address all of the key questions listed. This is explained on page 5-2.	<p>There is no explanation other than the study will address some key questions.</p> <p>Licensees' Response: <i>Please see previous response.</i></p>
WDFW – JIM BYRNE	1	AQU 05-3	Answer to questions.	<p>Answer to question 5, the other studies named do not really address specific flows through passage structures.</p> <p>Answer to question 7, Speelyai (AQU 9) only addresses a small portion of the watershed and (TER 6) deals primarily with erosion issues. They do not add much to answer this question.</p> <p>Some indication of preferred options and associated cost would have been helpful.</p>	<p>Flows through structures have been examined on a case-by-case basis for each set of fish passage facility alternatives.</p> <p>The Reservoir Fluctuation Study (TER 6), still in draft form, will address riparian connectivity when it is complete.</p> <p>There are no access or connectivity problems on the upper Lewis delta or at any of the tributaries even under the observed 100 foot drawdown that occurred in 2000.</p>	<p>(7) TER 6 does not deal with draw down effecting: predator and prey concentrations, silt and turbidity loading and fish stranding on the exposed mudflats. All of these are important to listed bull trout.</p> <p>Licensees' Response: <i>The objectives of this study did not include any of these parameters.</i></p>

Commenter	Volume	Page/ Paragraph	Statement	Comment	Response	Response to Responses
TWHB	1	AQU 05-4	System goals	Does not include lamprey nor specifically mention ESA stocks.	The fish passage investigation specifically targeted species listed in Section 4.5.3, Task 1. These are bull trout, wild steelhead, Chinook, native resident species, coho, sea-run cutthroat trout and kokanee. Even though these systems are not specifically designed for other species, they would assist in passing (except possibly lamprey) these species when they are operational.	
USDA Forest Service: John Kinney	1	AQU 05-4 para 1, second bullet	...anadromous salmon...	Reintroduction may emphasize anadromous <i>salmonids</i> ; however, serious consideration needs to be given to all migratory fish that fit with governing policies, i.e., CFRs, LRMP, etc.	The fish passage designs reflect current WDFW, USFWS, and NMFS fish passage criteria. Thus, it is assumed that facilities will pass all migratory species found in western Washington streams.	We would advocate inclusion of the historical fish assemblage when addressing the Lewis River below, within, and above the projects.
TWHB	1	AQU 05-5	Biological system goals and the ARG	It appears (pg 5 paragraph 1) they are attempting to pass the blame on the ARG. They indicate that the ARG was un-able to agree on biological system goals. As I understand the ARG, it is primarily comprised of technical representatives who haven't the authority to establish biological system goals. For example, YN would like a fish passage system that recognizes the needs of all native fish, but others have a limited focus	The absence of defined basin goals has been a frustration to many participants. Our desire has been to target the fish passage study toward the objectives desired by fisheries managers, and such guidance has not been forthcoming. We had hoped this information would be provided by agency representatives who are ARG	

Commenter	Volume	Page/ Paragraph	Statement	Comment	Response	Response to Responses
				ranging from anadromous salmon to only bull trout, also, where and how will the basin's extirpated stocks be restored. These policy decisions will greatly impact technical recommendations. As way of example, recent studies of lamprey passage at Columbia River salmon fish ladders have demonstrated some serious design flaws. Lampreys tend to move upstream against strong currents with the aid of their mouth. Sharp 90 degree turns in a fish ladder make fish passage difficult for the lamprey. Thus, a fix would be rounded turns and structures that would enable the ladder to have the look and feel (to the fish) of a natural waterfall or cascade. Thus a fish design that meets the minimum needs of salmon may not work well for lamprey. The report reference's a "final fish passage feasibility report due out in March 2002. I have not seen this report.	<p>participants. While we acknowledge the effect of the projects on the basin, the fact remains that fish managers need to define fishery management goals. We will rephrase the statement in the report to more clearly reflect this position.</p> <p>The fish passage report presented in this Technical Report (dated April 18, 2002) is the most recent version. It will not be considered final until these stakeholder comments are incorporated.</p>	
TWHB	1	AQU 05-5	Criteria Screens	This needs to be further described to include physical layout, expected FGE, and references.	More detail will be provided if criteria screens are incorporated into an alternative carried forward for analysis in the PDEA.	
J. Kaje – Tech.Adv. for Cowlitz Tribe	1	AQU 05-5 para 1	"...the inability of the ARG to better define	I find this language offensive. Many of the most important system goals are in fact settlement issues, e.g.,	Comment noted.	

Commenter	Volume	Page/ Paragraph	Statement	Comment	Response	Response to Responses
			and agree on biological system goals”	should anadromous stocks be reintroduced throughout the basin. It is not the role of the ARG to do so.		
J. Kaje – Tech.Adv. for Cowlitz Tribe	1	AQU 05-5, System 7	system description	Why does this bull trout oriented option not include a second upstream fishway entrance at the top of the bypass reach when such a feature seems particularly important for the goal of reconnecting the Yale and Swift populations? This comment also carries over into the system cost estimates in the Appendix.	As you noted in the previous comment, neither the ARG nor the policy group has identified that reconnecting the bull trout populations in Swift and Yale is a goal. This goal was included by the report authors as a way to develop alternatives.	
TWHB	1	AQU 05-various		The fish passage report is only a general description of proposed fish passage alternatives. Thus, the draft-Phase 1 report (July 2001) is the most detailed and AQU5- Appendix provide the most detail. The fish passage issue is the most important, technically complicated, and potentially costly aspect of the re-licensing project. Providing flows for the river and fish passage are also important.	Comment noted.	Verbal comments were provided to Frank Shrier (PacifiCorp) at the 10/1/02 ARG meeting. Mr. Backman requested more detail that the response provided. Licensees’ Response: <i>The objective of the Fish Passage Report was to identify and evaluate conceptual design concepts for the Lewis River projects. Detailed design criteria will be developed based on the alternative included in the final FERC license order.</i>

AQU 5 Appendix 1

*Engineering Feasibility Study
for Fish Passage Facilities – Phase Two*

This page intentionally blank.

Final

**Engineering Feasibility Study
for Fish Passage Facilities – Phase 2**

for the

Lewis River Hydroelectric Projects

**Merwin Hydroelectric Project, FERC No. 935
Yale Hydroelectric Project, FERC No. 2071
Swift No. 1 Hydroelectric Project, FERC No. 2111
Swift No. 2 Hydroelectric Project, FERC No. 2213**

October 7, 2002

Prepared for

**PacifiCorp
Portland, Oregon**

and

**Public Utility District No. 1 of Cowlitz County
Longview, Washington**

Prepared by



In Association With

Mobrand Biometrics

PacifiCorp / Cowlitz PUD
Lewis River Hydroelectric Projects
FERC Project Nos. 935, 2071, 2111, 2213

This page intentionally blank.

TABLE OF CONTENTS

1.0 INTRODUCTION 1

 1.1 TECHNICAL STUDY OBJECTIVES..... 1

 1.2 COORDINATION WITH PHASE 1 REPORT 2

 1.3 PHASE 2 REPORT ORGANIZATION..... 2

2.0 UPDATED DESIGN CRITERIA..... 3

 2.1 RUN TIMING DESIGN VALUES 3

 2.1.1 Upstream Run Timing Design Values 3

 2.1.2 Downstream Run Timing – Design Values 3

 2.2 RESERVOIR AND TAILWATER DESIGN ELEVATIONS 5

 2.2.1 Merwin Reservoir and Tailwater Design Values for Upstream
 Passage 5

 2.2.2 Merwin Reservoir and Tailwater Design Values for Downstream
 Passage 7

 2.2.3 Yale Reservoir and Tailwater Design Values for Upstream Passage..... 8

 2.2.4 Yale Reservoir and Tailwater Design Values for Downstream
 Passage 9

 2.2.5 Swift Project’s Reservoir and Tailwater Design Values for
 Upstream Passage..... 11

 2.2.6 Swift Reservoir and Tailwater Design Values for Downstream
 Passage 12

 2.3 DESIGN FLOWS..... 13

 2.4 OPERATIONAL CONSIDERATIONS 14

3.0 FISH PASSAGE SYSTEM DEVELOPMENT..... 15

 3.1 SYSTEM GOALS 15

 3.2 SYSTEM ALTERNATIVES 15

 3.2.1 System 1: Volitional Passage with Criteria Screens..... 17

 3.2.2 System 2: Volitional Passage with Surface Collectors..... 19

 3.2.3 System 3: Fish Lifts Upstream, Surface Collectors Downstream 21

 3.2.4 System 4: Fish Lifts Upstream, Surface Collectors Downstream
 with Trucking Facilities 23

 3.2.5 System 5: Trap-and-Haul to Upper Swift with Surface Collectors 25

 3.2.6 System 6: Trap-and-Haul to Upper Swift with Screens (bypass
 Merwin and Yale)..... 27

 3.2.7 System 7: Resident Trap-and-Haul (no anadromous reintroduction)..... 29

 3.3 DISCUSSION..... 31

4.0 UPSTREAM PASSAGE FACILITIES 32

 4.1 PHASE 2 FACILITY INFORMATION 32

 4.2 REFERENCE TO COST INFORMATION..... 35

 4.3 MERWIN DAM UPSTREAM ALTERNATIVES..... 35

4.3.1	MU-1, Merwin Dam Fish Ladder	36
4.3.2	MU-2, Merwin Dam Trap and Haul, Alt 1 – Existing Fish Lift.....	40
4.3.3	MU-3, Merwin Dam Trap and Haul, Alt 2 – Ladder to Holding Ponds	42
4.3.4	MU-4, Fish Lift to Reservoir	42
4.3.5	MU-5, Fish Lock to Reservoir	43
4.4	YALE DAM UPSTREAM ALTERNATIVES	43
4.4.1	YU-1, Yale Dam Fish Ladder.....	43
4.4.2	YU-2, Yale Trap and Haul.....	47
4.4.3	YU-3, Yale Fish Lift.....	47
4.4.4	YU-4, Yale Fish Lock.....	47
4.5	SWIFT COMPLEX UPSTREAM PASSAGE ALTERNATIVES	47
4.5.1	SU-1, Swift Complex Fish Ladders	48
4.5.2	SU-2, Swift Complex Trap-and-Haul	53
4.5.3	SU-3, Swift Fish Lift to Reservoir.....	54
4.5.4	SU-4, Swift Fish Lock	54
5.0	DOWNSTREAM PASSAGE FACILITIES	54
5.1	PHASE 2 DOWNSTREAM FACILITY INFORMATION.....	54
5.2	REFERENCE TO COST INFORMATION.....	54
5.3	UPPER SWIFT RESERVOIR	57
5.3.1	USD-1 Mobile Juvenile Collectors.....	57
5.4	SWIFT DAM DOWNSTREAM PASSAGE FACILITIES	57
5.4.1	S1D-1 0.4 FPS V-Screens.....	58
5.4.2	S1D-2 0.8 fps V-Screens	59
5.4.3	S1D-3 Surface Collector Alt 1, Gate in Spillway.....	59
5.4.4	S1D-4 Surface Collector Alt 2, Floating Surface Collector	60
5.4.5	S1D-5 Gulper.....	61
5.5	SWIFT NO. 2 POWERHOUSE	61
5.6	YALE DAM DOWNSTREAM PASSAGE FACILITIES	61
5.6.1	Downstream Passage Alternatives.....	61
5.7	MERWIN DAM DOWNSTREAM PASSAGE FACILITIES	61
5.7.1	Downstream Passage Alternatives.....	61
5.8	LOWER BASIN.....	65
5.8.1	LB-1, Stress Relief Pond Facility	65
6.0	PLANNING LEVEL COST ESTIMATES	66
6.1	FACILITY COSTS	66
6.2	SYSTEM COST DEVELOPMENT.....	66
6.3	SYSTEM COST SUMMARY	69
7.0	LITERATURE CITED	70

LIST OF TABLES

Table 2.2-1. Upstream passage design elevations for Merwin Dam.	5
Table 2.2-2. Downstream passage design elevations for Merwin Dam.	7
Table 2.2-3. Upstream passage design elevations for Yale Dam.	8
Table 2.2-4. Downstream passage design elevations for Yale Dam.....	9
Table 2.2-5. Upstream passage design elevations for the Swift No. 1 and Swift No. 2 projects.....	11
Table 2.2-6. Downstream passage design elevations for the Swift No. 1 and Swift No. 2 projects.....	12
Table 2.3-1. Design flow summary for passage facilities.....	13
Table 3.3-1. Juvenile survival estimates for passage through reservoirs, turbines and bypass systems.	31
Table 3.3-2. Adult survival estimate for volitional and trap-and-haul facilities.....	31
Table 4.3-1. Calculated mean velocities at Merwin tailrace, Units 1 & 2.....	36
Table 4.3-2. Calculated mean velocities at Merwin tailrace, Unit 3.....	36
Table 4.4-1. Calculated mean velocities at Yale tailrace, Units 1 &2.	44
Table 4.5-1. Calculated mean velocities at Swift No. 2 Tailrace, Units 1 & 2	48
Table 4.5-2. Calculated mean velocities at Swift No. 1 tailrace, Units 1 through 3.....	49
Table 6.2-1. System Cost Detail.	67
Table 6.3-1. System Cost Summary	69

LIST OF FIGURES

Figure 2.1-1. Merwin Dam: Run Timing & Monthly Flows.	4
Figure 2.2-1. Merwin tailwater elevations and upstream fish migration timing.	6
Figure 2.2-2. Lake Merwin reservoir elevations and upstream fish migration timing.	6
Figure 2.2-3. Lake Merwin elevations and downstream fish migration timing.....	7
Figure 2.2-4. Merwin tailwater elevations and downstream fish migration timing.....	8
Figure 2.2-5. Yale tailwater elevations and upstream fish migration timing at fishway entrance.	8
Figure 2.2-6. Yale Lake elevations and upstream fish migration timing.....	9
Figure 2.2-7. Yale Reservoir elevations and downstream fish migration timing.	10
Figure 2.2-8. Yale tailwater elevations and downstream fish migration timing.....	10
Figure 2.2-9. Swift No. 2 tailwater elevations and upstream fish migration timing at fishway entrance.	11
Figure 2.2-10. Swift Reservoir elevations and upstream fish migration timing.....	11
Figure 2.2-11. Swift Reservoir elevations and downstream fish migration timing.	12
Figure 2.2-12. Swift No. 2 tailwater elevations and downstream fish migration timing.	13
Figure 3.2-1. Volitional passage with criteria screens.	17
Figure 3.2-2. Volitional upstream passage with downstream surface collectors.....	19
Figure 3.2-3. Volitional upstream passage with downstream surface collectors.....	21
Figure 3.2-4. Fish lifts upstream, surface collectors downstream with trucking facilities.....	23
Figure 3.2-5. Trap-and-haul to upper Swift with surface collectors downstream.	25

Figure 3.2-6. Trap-and-haul to upper Swift with screens.	27
Figure 3.2-7. Resident trap-and-haul (no anadromous reintroduction).	29
Figure 4.1-1. Key to Upstream Passage Facilities.	33
Figure 4.3-1. Merwin Dam draft tube configuration.	37
Figure 4.4-1. Yale Dam draft tube configuration.	45
Figure 4.5-1. Swift No. 2 draft tube configuration.	50
Figure 4.5-2. Swift No. 1 draft tube configuration.	51
Figure 5.1-1. Key to downstream passage facilities.	55
Figure 5.6-1. Yale Project Spillway Extension Project	63

LIST OF DRAWINGS

TAB A – UPSTREAM PASSAGE FACILITY DRAWINGS

MU-1 Merwin Dam Fish Ladder

- MU-1.1 Merwin Dam, Fish Ladder Plan
- MU-1.2 Merwin Dam, Fish Ladder Profile
- MU-1.3 Merwin Dam, Fish Ladder Typical Sections
- MU-1.4 Merwin Dam, Fish Ladder Sections
- MU-1.5 Merwin Dam, Fish Ladder Entrance Plan Existing Entrance Alt
- MU-1.6 Merwin Dam, Fish Ladder Entrance Sections, Existing Entrance Alt
- MU-1.7 Merwin Dam, Fish Ladder Exit Plan and Elevation
- MU-1.8 Merwin Dam, Fish Ladder Exit Sections

MU-2 Merwin Dam, Trap & Haul, Alt 1 – Existing Fish Elevator

- MU-2.1 Merwin Dam, Trap & Haul Alt 1, Existing Entrance Plan
- MU-2.2 Merwin Dam, Trap & Haul Alt 1, Existing Entrance Details
- MU-2.3 Merwin Dam, Trap & Haul Alt 1, Existing Lift Section

MU-3 Merwin Dam Trap & Haul, Alt 2 – Ladder to Holding Ponds

- MU-3.1 Merwin Dam, Trap & Haul Alt 2, Plan
- MU-3.2 Merwin Dam, Trap & Haul Alt 2, Enlarged Plan
- MU-3.3 Merwin Dam, Trap & Haul Alt 2, Sections
- MU-3.4 Merwin Dam, Trap & Haul Alt 2, Transfer Facility Sections

MU-4 Merwin Dam Fish Lift to Reservoir

- MU-4.1 Merwin Dam, Fish Lift To Reservoir Plan
- SU-1.3 Swift Fish Ladder Sections

YU-1 Yale Dam Fish Ladder

- YU-1.1 Yale Dam Fish Ladder Plan
- YU-1.2 Yale Dam Fish Ladder Profile
- YU-1.3 Yale Dam Fish Ladder Sections
- YU-1.4 Yale Dam Fish Ladder Entrance Enlarged Plan
- YU-1.5 Yale Dam Fish Ladder Exit Plan & Elevation
- YU-1.6 Yale Dam Fish Ladder Exit Sections

YU-2 Yale Dam Trap-and-Haul
YU-2.1 Yale Dam Trap-and-Haul Plan

SU-1 Swift No. 2 and Swift No. 1 Fish Ladders
SU-1.1 Swift No. 2 Fish Ladder Plan
SU-1.2 Swift No. 1 Fish Ladder Plan
SU-1.3 Swift No. 1 Fish Ladder Sections
SU-1.4 Swift No. 1 Fish Ladder Exit Elevation

TAB B – DOWNSTREAM PASSAGE FACILITY DRAWINGS

S1D-1 Swift No. 1, 0.4 FPS V-Screen
S1D-1.1 Swift No. 1, 0.4 FPS V-Screen, Plan
S1D-1.2 Swift No. 1, 0.4 FPS V-Screen, Enlarged Plan & Elevation
S1D-1.3 Upper Swift Juvenile Collector, Sorting & Handling Facility Plan

S1D-2 Swift No. 1, 0.8 FPS V-Screen
S1D-2.1 Swift No. 1, 0.8 FPS V-Screen, Plan
S1D-2.2 Swift No. 1, 0.8 FPS V-Screen, Enlarged Plan & Elevation

S1D-3 Swift No. 1, Surface Collector Alt 1
S1D-3.1 Swift No. 1, Surface Collector Alt 1, Plan & Profile

S1D-4 Swift No. 1, Surface Collector Alt 2
S1D-4.1 Swift No. 1, Surface Collector Alt 2, Plan
S1D-4.2 Swift No. 1, Surface Collector Alt 2, Profile

S1D-5 Swift No. 1, gulper
S1D-5.1 Swift No. 1, Gulper Plan
S1D-5.2 Swift No. 1, Gulper Sections

TAB C - APPENDICES

Appendix A – WDFW Comment Letter on Phase 1 Report

Appendix B – Facility Cost Estimate Spreadsheets

This page intentionally blank.

EXECUTIVE SUMMARY

This Phase 2 report of the Engineering Feasibility Study for Fish Passage Facilities supplements the Draft Phase 1 report, and is not intended to be a stand alone document. The Phase 1 and Phase 2 reports together address the goals of Technical Study AQU 5, and aquatic alternatives identified in the Resource Enhancement Alternatives Document (READ) process.

The primary focus of the Phase 1 report was to identify physical *facilities* capable of meeting fish passage objectives for the Lewis River basin in support of the Federal Energy Regulatory Commission (FERC) relicensing process. The Phase 1 report provided a comprehensive record of program and facility goals, and documented criteria and data relevant to the design of fish passage facilities. It also provided physical design constraints of the existing facilities at each project, as well as biological design information and assumptions.

At the time of the Phase 1 report's publication (July 2001), the Aquatics Resource Group (ARG) had not identified basin goals requiring specific fish passage facilities. Because different facilities will produce varying passage effectiveness, the Phase 1 report identified 5 potential fish passage *systems*, on which various facilities could be evaluated. The 5 systems represented a wide range of potential basin goals. Development of fish passage alternatives was based on providing facilities that could cover the full range of basin alternatives.

Conceptual designs of reasonable fish passage facilities were developed to help confirm and otherwise address their feasibility. These individual facilities were presented for comment in the Phase 1 report. To date (February 2002), the only comments received on the Phase 1 document were from the Washington Department of Fish and Wildlife (WDFW). Additionally, the ARG has not yet developed nor agreed to a specific basin plan. Work currently underway by the ARG on the Lewis River Fish Passage Model will help guide the group on development of a basin plan. This study is currently ongoing, with initial results expected in March 2002. Therefore, this Phase 2 report provides an overview of 7 potential basin fisheries goals, which are intended to address all positions discussed by the ARG to date. Absent more specific direction, development of these hypothetical systems was necessary to better define specific facility goals.

This Phase 2 report builds on the Phase 1 effort to: address comments received from ARG members; provide additional information to clarify operational intent and in sufficient detail to accurately estimate facility costs; and provide an engineering estimate of potential facility and system costs.

This report was not intended to repeat information developed in Phase 1. For example, no information is presented on assumed biological effectiveness of each system since this was discussed in Phase 1. Pertinent data or assumptions that have changed since the Phase 1 report are noted and addressed.

This page intentionally blank.

1.0 INTRODUCTION

1.1 TECHNICAL STUDY OBJECTIVES

The goals of the Engineering Feasibility Study for Fish Passage Facilities (AQU 5) are to evaluate the feasibility of constructing fish passage facilities at Merwin, Yale, and Swift dams to reduce fish entrainment risks; and to identify and/or conceptually develop facilities that would accommodate a possible re-introduction of anadromous fish to the upper Lewis River.

This report addresses the following objectives identified in the study plan for AQU 5 (PacifiCorp and Cowlitz PUD 1999, as amended):

- Determine the engineering feasibility of constructing both upstream and downstream fish passage facilities at the Lewis River Hydro Projects.
- Determine or estimate the biological effectiveness of each upstream and downstream fish passage facility examined, and quantify the unknowns surrounding each facility component.
- Combine feasible facilities into fish passage systems that are both biologically effective and capable of meeting the range of fish management objectives being developed by the ARG.
- Quantify the unknowns or additional data necessary to make informed decisions on selecting fish passage system alternatives.
- Identify and describe the impacts that proposed facilities would have on water quality, power production, reservoir operations, and other overall project components.
- Provide planning level cost estimates and identify key cost components (such as construct ability issues) to assist in comparing alternatives (Phase 2).
- Provide technical details and support to the Resource Enhancement Alternatives Document (READ) process.

This report does not specifically address the objective to “determine or estimate the biological effectiveness of each upstream and downstream fish passage system examined.” System variables and fish survival estimates for the various facilities are an ongoing topic of discussion with the ARG. In order to address the numerous variables and unknowns associated with fish survival and biological effectiveness, the ARG has commissioned the Lewis River Fish Passage Model (LRFPM), which is currently under development. This biologically based model will help guide the ARG in defining an overall basin plan. Results from the LRFPM are expected as early as March 2002. This report will provide facility concepts for use by the ARG in developing estimated values for input to the LRFPM.

1.2 COORDINATION WITH PHASE 1 REPORT

This Phase 2 report provides updated or new information to supplement that presented in the Phase 1 report on the Engineering Feasibility Study for Fish Passage Facilities. It is responsive to several AQU 5 study goals:

- Addresses comments received from the ARG on the Phase 1 report;
- Provides revised fish passage system definitions;
- Provides technical information about fish passage facility alternatives;
- Provides cost estimates for both fish passage facilities and complete fish passage systems; and
- Provides a discussion on evaluation of the various fish passage facilities and systems.

This report is not intended to be a stand-alone document, and no attempt has been made to intentionally repeat information provided in the Phase 1 report. Pertinent data or assumptions that have changed since the Phase 1 report are noted and addressed. The reader will be directed to the Phase 1 report where applicable.

Written comments received on the Phase 1 report are presented at Tab C, Appendix A. The only written comments received to date are from the WDFW. Verbal comments received during both the ARG and READ meetings are addressed throughout the report.

1.3 PHASE 2 REPORT ORGANIZATION

Section 1 – Offers an overview of the Engineering Feasibility Study for Fish Passage Facilities at Merwin, Yale and Swift dams.

Section 2 – Provides an updated and abbreviated list of criteria important to the fish passage study, largely resulting from comments received on the Phase 1 report.

Section 3 – Because the ARG has not yet provided a final set of basin fisheries goals, this section provides an overview of potential system plans and lists 7 individual fish passage systems on which to base the evaluation of various facilities. Similar to the 5 systems presented in the Phase 1 report, the intent of the 7 systems was to identify the broad range of system goals discussed by the ARG.

Section 4 – Provides additional information on upstream passage facilities, based on the system goals and comments.

Section 5 – Presents additional information and detail on downstream passage facilities, based on system goals and comments.

Section 6 – Provides planning-level cost estimates for the 7 fish passage systems, along with cost information for individual fish passage facilities.

Additional cost detail is provided in Tab C, Appendix B. Technical drawings are provided under Tabs A and B at the end of the report.

2.0 UPDATED DESIGN CRITERIA

2.1 RUN TIMING DESIGN VALUES

The Phase 1 report identified biological run timing information and statistical reservoir elevations, which were identified as fish passage facility design criteria. This conservative approach identified reservoir fluctuations that would be in excess of those typically occurring when the fish species of concern are migrating.

This section identifies upstream and downstream run timing values that will help to refine the necessary reservoir fluctuation design values for fish passage facilities. The intent with narrowing the design fluctuation level is to both increase the potential performance of fish passage facilities, and to reduce the complexity and cost of these facilities.

Depending on the specific basin goal or system plan, various species may or may not be present at each facility. Values shown in this section present an estimate of likely migration windows by species. Figure 2.1-1 is reproduced from the Phase 1 report to provide a consolidated view of basin hydrology and the run timing by species at Merwin Dam. It is recognized that depending on the fisheries goals eventually selected by the ARG, not all species may be present at each project.

2.1.1 Upstream Run Timing Design Values

The specific run timing and target species may vary by project, depending on which species are allowed into each river reach. This information is currently under review by the ARG, and more specific design goals by species are expected to be developed from the LRFPM. In lieu of any specific direction from the ARG, fish facilities are designed for year round upstream migration.

2.1.2 Downstream Run Timing – Design Values

Downstream passage facilities would be designed for operation from April 1 through July 31 for coho, summer steelhead, winter steelhead, chum, sea run cutthroat, fall chinook, and spring chinook.

Due to the report's stated intent, the downstream collection window does not take into account bull trout, Pacific lamprey, or kokanee. Design flows would be controlled by the start date of the out-migration season, coinciding with the highest flows and the largest reservoir fluctuation. These migration windows were used to develop the reservoir fluctuation parameters, described in Section 2.2.

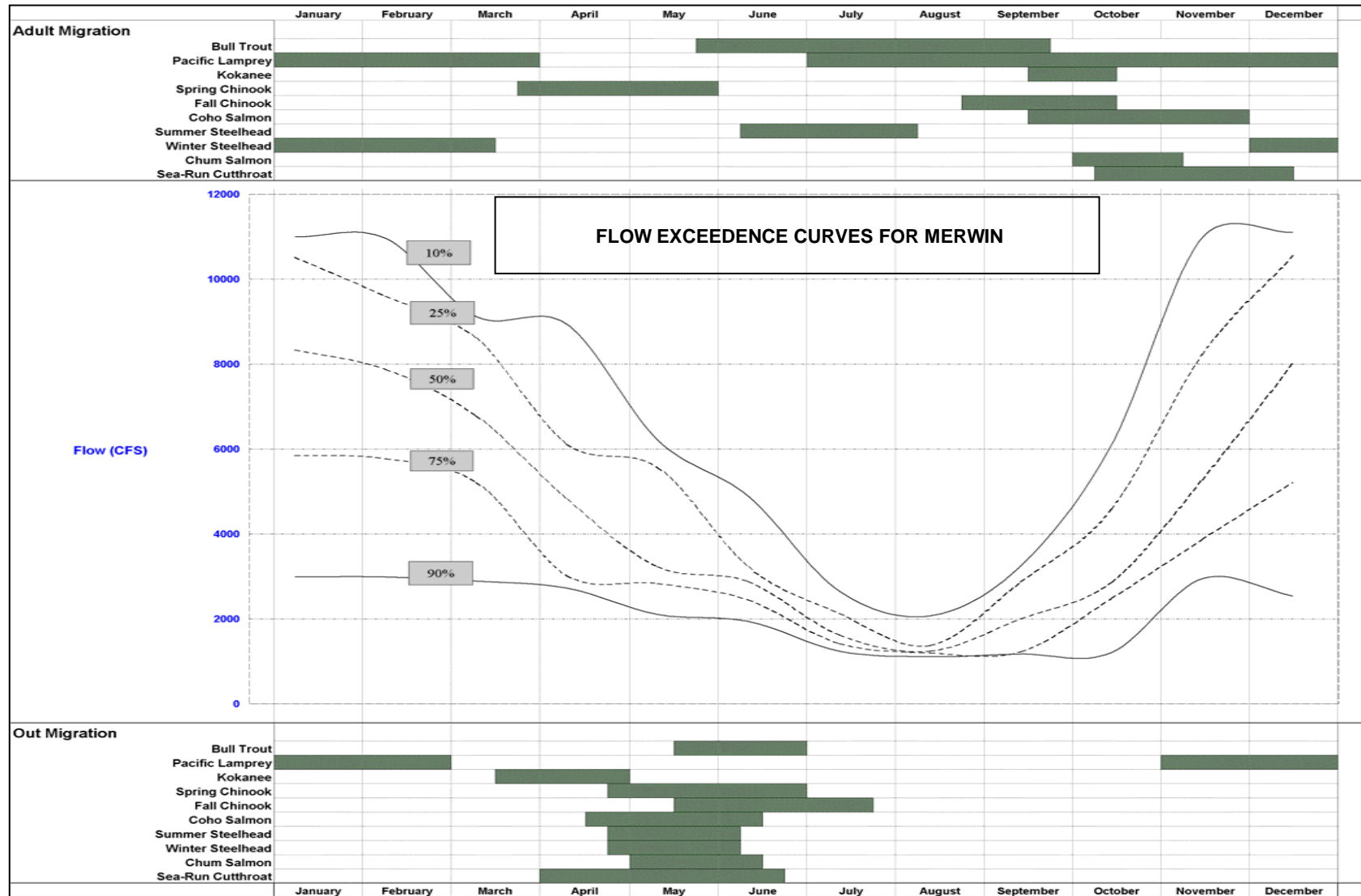

Source: Unpublished data PacifiCorp 1989-2000a

Source: PacifiCorp and Cowlitz Co. PUD 2001

Figure 2.1-1. Merwin Dam: Run Timing & Monthly Flows.

2.2 RESERVOIR AND TAILWATER DESIGN ELEVATIONS

This section defines reservoir fluctuation design values proposed for each project during the fish migration seasons, based on the run timing information stated in Section 2.1.

Important variables to define upstream passage facilities are:

- tailwater fluctuation elevations for the design of entrances to the adult passage facilities, and
- reservoir fluctuation elevations for the design of adult passage exit facilities into the reservoirs.

The variables needed to develop the downstream passage facilities are:

- reservoir fluctuation values for the design of juvenile collection facilities, and
- tailwater fluctuation elevations for the design of juvenile bypass system exit facilities.

Flood values for both the tailwater and reservoir elevations are also important to develop facility designs.

This section provides a set of summary figures and tables showing proposed design values for upstream and downstream passage at Merwin, Yale, Swift No. 1 and Swift No. 2. The figures provide a comprehensive basis for the proposed design elevations. Base data for each figure was provided in the Phase 1 report, along with supporting information. A discussion of project operational constraints associated with the conceptual fish passage facility designs follows the figures for each project.

The design values presented in this section are reflected on the conceptual design drawings, and have been used to develop planning level cost estimates for the primary facilities (see Section 6). Conceptual drawings included in this report have been revised from the Phase 1 report to reflect these design elevations.

2.2.1 Merwin Reservoir and Tailwater Design Values for Upstream Passage

Table 2.2-1 summarizes the proposed tailwater and reservoir values for the design of upstream passage facilities at Merwin Dam. Figures 2.2-1 and 2.2-2 illustrate these proposed design elevations relative to the tailwater and reservoir historic elevations.

Table 2.2-1. Upstream passage design elevations for Merwin Dam.

	High Elevation	Low Elevation	Fluctuation (ft)
Tailwater	54.0	46.0	8.0
Reservoir	239.6	227.0	12.6

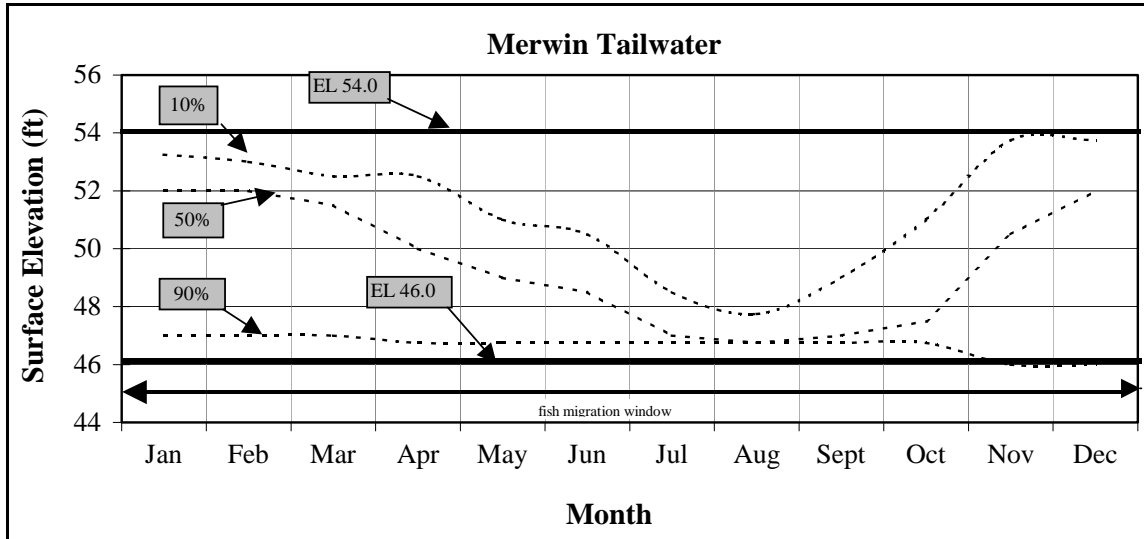

Figure 2.2-1. Merwin tailwater elevations (January 1, 1989 through December 19, 2000) and upstream fish migration timing.

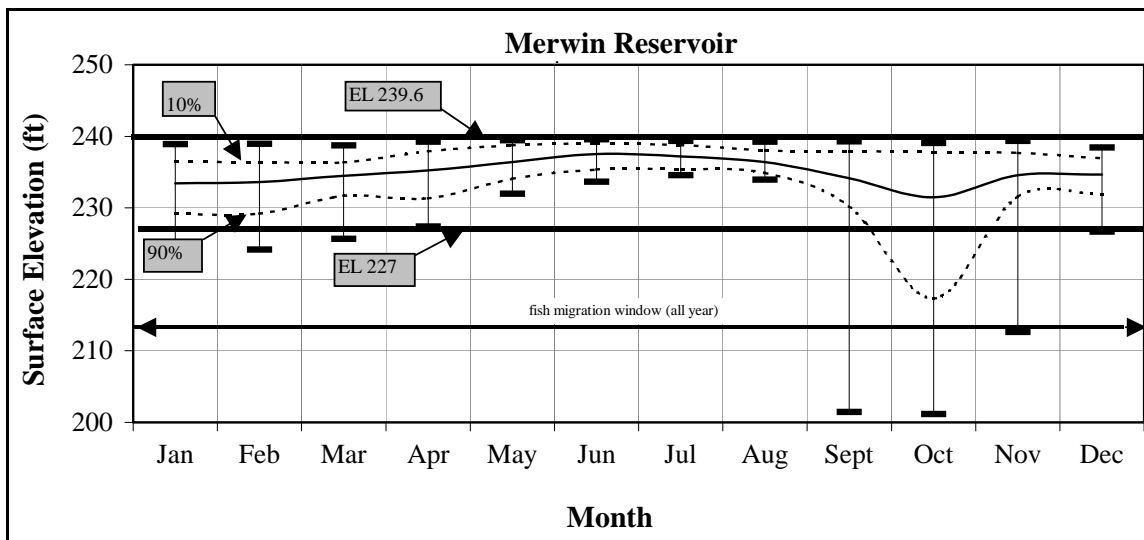

Figure 2.2-2. Lake Merwin reservoir elevations (Jan. 1, 1989 through Dec. 19, 2000) and upstream fish migration timing.

The error bars shown on Figure 2.2-2 document historical reservoir elevations by month. By selecting a low elevation of 227 feet, the primary upstream passage facilities would operate for nearly all of the 90-percent exceedence flows when fish are present. The statistical presentation shown for September through October is somewhat misleading. The low drawdown periods shown in these months are typically due to FERC-mandated operation and maintenance (O&M) requirements. Merwin Reservoir is drawn down 23 feet (to elevation 216.0 feet msl) every 5 years for FERC-mandated spillway gate inspections. These inspections are currently timed to coincide with the low flow months when the reservoir is dropping (from September through November). The duration of the inspection drawdown varies from 2-hours to 2-weeks.

The impact of these planned O&M drawdowns on upstream fish passage exit facilities could be mitigated by manipulating the timing of these mandatory inspections to minimize impacts on facility’s fish passage performance, and by providing backup facilities that will operate during extreme drawdowns. Backup exit facilities would primarily be applicable to fishladder or dedicated trap designs that have a fixed exit structure. In these cases, either a slide type exit from the lowest exit portal could be provided to discharge upstream migrants into the low reservoir, or a backup trap and haul system that would be associated with any trap could be designed to function during periods of extreme low reservoir levels. For trap-and-haul based upstream passage, ramps or release pipes at selected fish release sites would be designed to accommodate the extreme low reservoir levels.

2.2.2 Merwin Reservoir and Tailwater Design Values for Downstream Passage

Table 2.2-2 summarizes the proposed tailwater and reservoir values for the design of downstream passage facilities at the Merwin Project. Figures 2.2-3 and 2.2-4 illustrate these proposed design elevations relative to the historic tailwater and reservoir elevations.

Table 2.2-2. Downstream passage design elevations for Merwin Dam.

	High Elevation	Low Elevation	Fluctuation (ft)
Reservoir	239.6	230.0	10.0
Tailwater	54.0	46.5	7.5

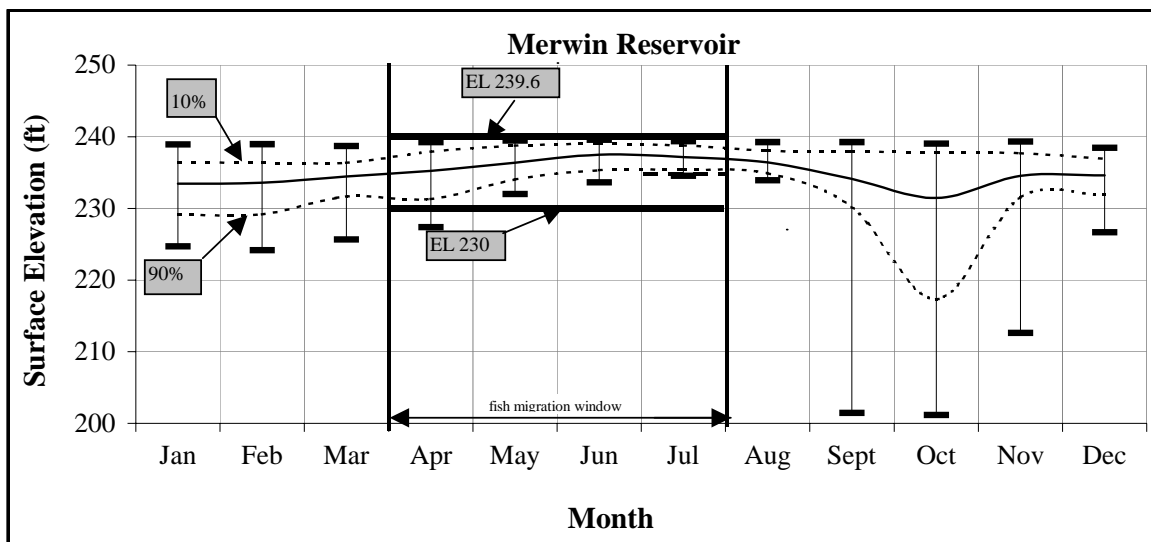

Figure 2.2-3. Lake Merwin elevations (January 1, 1989 through December 19, 2000) and downstream fish migration timing.

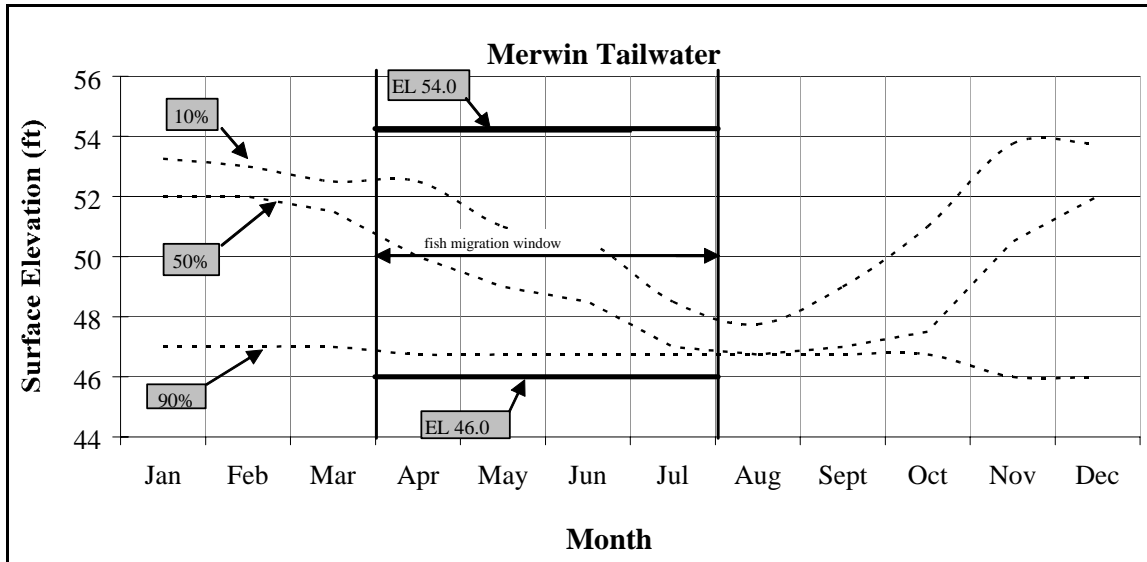

Figure 2.2-4. Merwin tailwater elevations (January 1, 1989 through December 19, 2000) and downstream fish migration timing.

2.2.3 Yale Reservoir and Tailwater Design Values for Upstream Passage

Table 2.2-3 summarizes the proposed tailwater and reservoir values for the design of upstream passage facilities at the Yale Project. Figures 2.2-5 and 2.2-6 illustrate these proposed design elevations relative to the historic tailwater elevation at the fishway entrance, and reservoir historic elevations.

Table 2.2-3. Upstream passage design elevations for Yale Dam.

	High Elevation	Low Elevation	Fluctuation (ft)
Tailwater	240.0	231.5	8.5
Reservoir	490.0	474.0	16.0

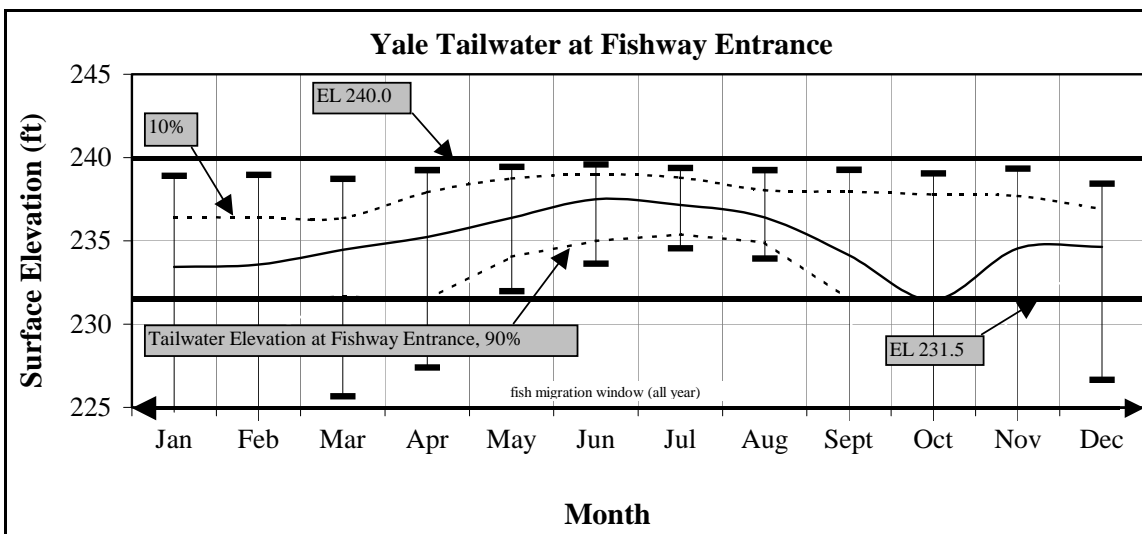

Figure 2.2-5. Yale tailwater elevations (January 1, 1989 through December 19, 2000) and upstream fish migration timing at fishway entrance.

Note that the minimum tailwater elevation of 231.5 shown on Figure 2.2-5 is controlled by open channel flow at the fishway entrance, and not by Merwin Reservoir levels. The proposed criteria for fish entrances will accommodate year-round facility operation.

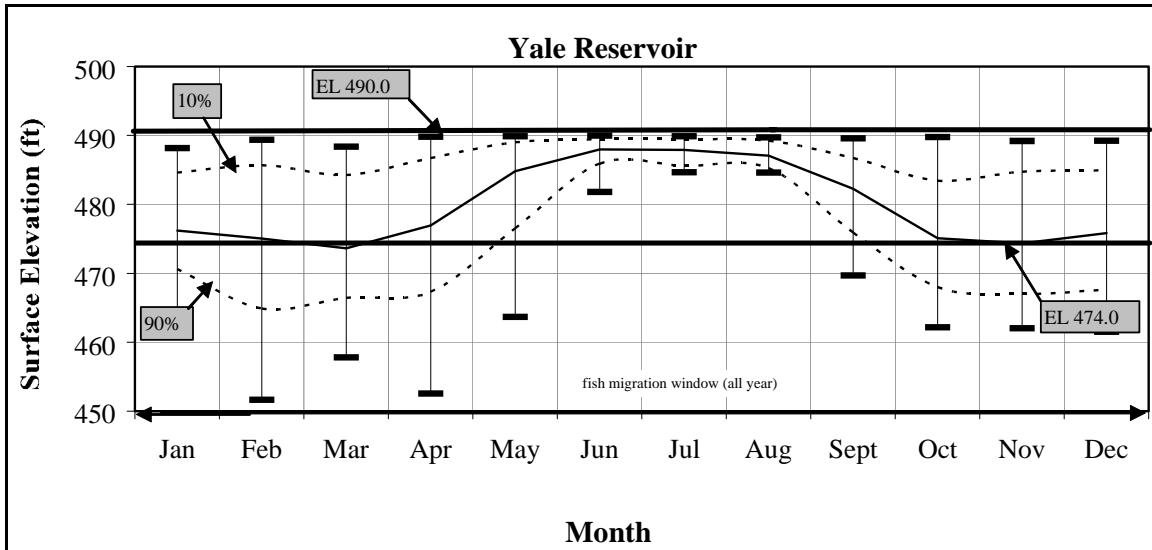

Figure 2.2-6. Yale Lake elevations (January 1, 1989 through December 19, 2000) and upstream fish migration timing.

Similar to the Merwin Project, Yale Lake is drawn down 25 feet (to Elevation 465.5) every 5 years for FERC-mandated spillway gate inspections, typically during the low flow months when the reservoir is dropping (from September through November). The duration of the inspection varies from 2 hours to 2 weeks, and this period could be managed to accommodate fish passage to the extent possible depending on basin goals. The design reservoir elevations proposed for the Yale project upstream passage release facilities are more restrictive than at Lake Merwin. Given the potential for large fluctuations to the full 90-percent exceedence elevation values, the design fluctuation is limited to 16 feet in an effort to optimize facility performance over a narrower operating range. However, upstream migrating fish can be present when the reservoir is lowered to elevation 465. As noted for the Merwin project, alternate release facilities such as a slide or chute could be installed to discharge fish into the reservoir, similar to criteria described for Merwin. Additionally, release facilities for trap-and-haul based upstream passage can be designed to be operational at all levels.

2.2.4 Yale Reservoir and Tailwater Design Values for Downstream Passage

Table 2.2-4 summarizes the proposed tailwater and reservoir values for the design of downstream passage facilities at the Yale Project. Figures 2.2-7 and 2.2-8 illustrate these proposed design elevations relative to the historic tailwater and reservoir elevations.

Table 2.2-4. Downstream passage design elevations for Yale Dam.

	High Elevation	Low Elevation	Fluctuation (ft)
Reservoir	490.0	474.0	16.0
Tailwater	240.0	231.5	8.5

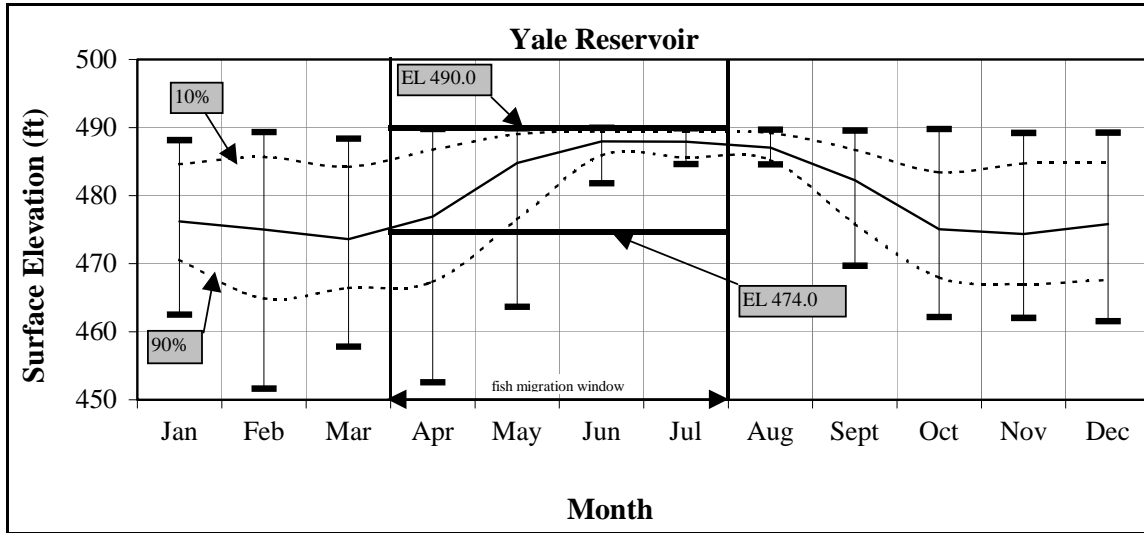

Figure 2.2-7. Yale Reservoir elevations (January 1, 1989 through December 19, 2000) and downstream fish migration timing.

As illustrated in Figure 2.2-7 during the month of April the operational low design elevation is limited to the 50% exceedence value at elevation 474 feet msl. In order to accommodate the full 90% exceedence value when outmigrating fish are present, the operational low design elevation for juvenile passage facilities would need to drop approximately 9 feet, to elevation 465 feet msl. This compromise in criteria is proposed in an effort to increase the operational efficiency of the design based on the assumption that juvenile collection/passage facilities designed to operate over a smaller fluctuation range will be more effective. It is also worth noting that the proposed elevation will accommodate the entire 90% exceedence elevation beginning in early May, prior to the anticipated peak of the outmigration season. An increase to the operational elevation range can be accommodated at a higher cost and potential loss of fish passage efficiency.

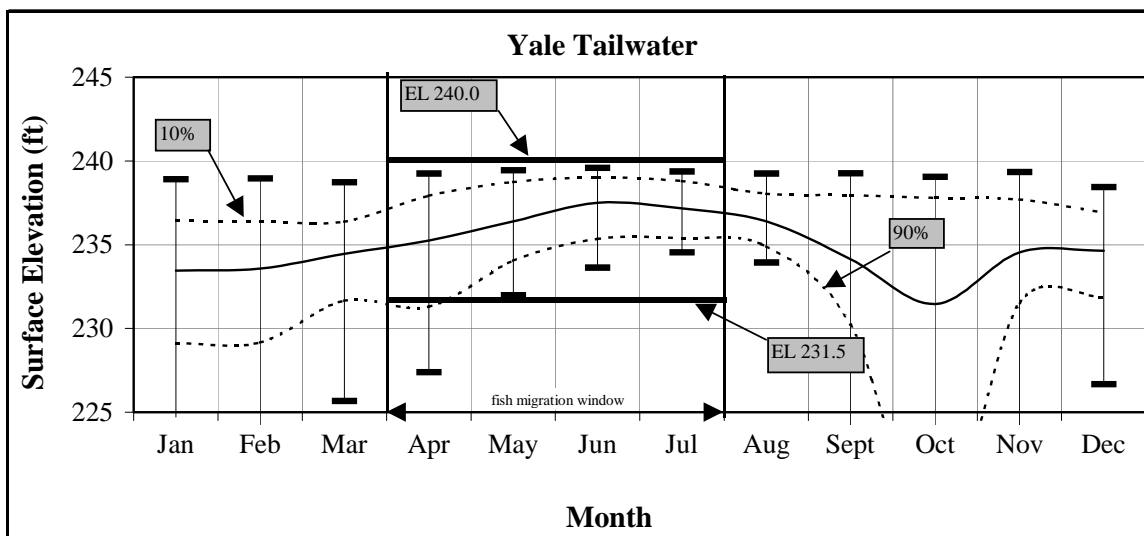

Figure 2.2-8. Yale tailwater elevations (January 1, 1989 through December 19, 2000) and downstream fish migration timing.

2.2.5 Swift Project's Reservoir and Tailwater Design Values for Upstream Passage

Table 2.2-5 summarizes the proposed tailwater and reservoir values for the design of upstream passage facilities at the Swift No. 1 and Swift No. 2 projects. Figures 2.2-9 and 2.2-10 illustrate these proposed design elevations relative to the historic tailwater and reservoir elevations.

Table 2.2-5. Upstream passage design elevations for the Swift No. 1 and Swift No. 2 projects.

	High Elevation	Low Elevation	Fluctuation (ft)
Swift No. 2 Tailwater	490.0	474.0	16.0
Swift No. 1 Tailwater (no curve)	604.0	602.0	2.0
Swift Reservoir	1000.0	960.0	40.0

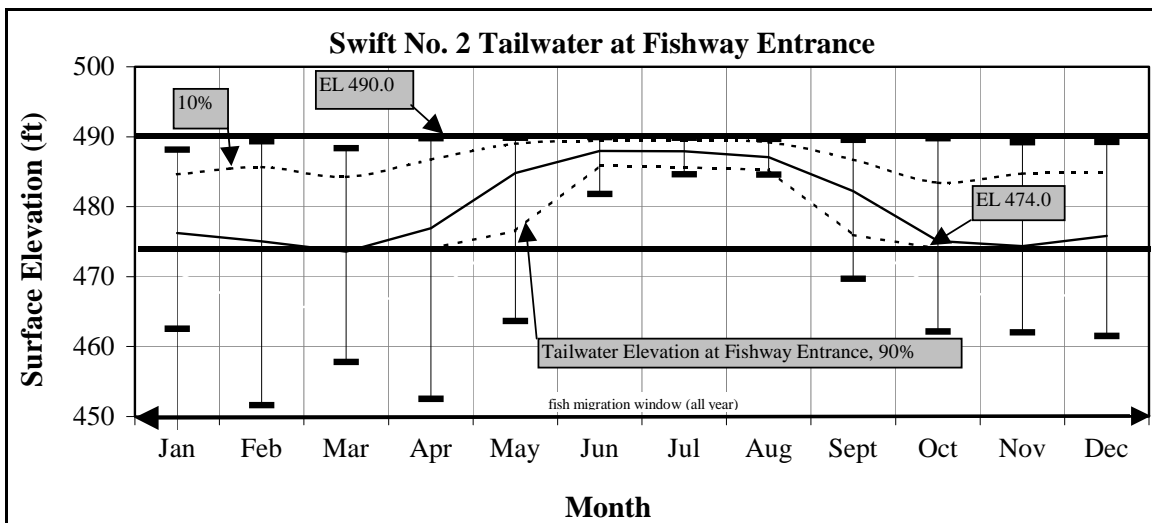

Figure 2.2-9. Swift No. 2 tailwater elevations and (January 1, 1989 through December 19, 2000) upstream fish migration timing at fishway entrance.

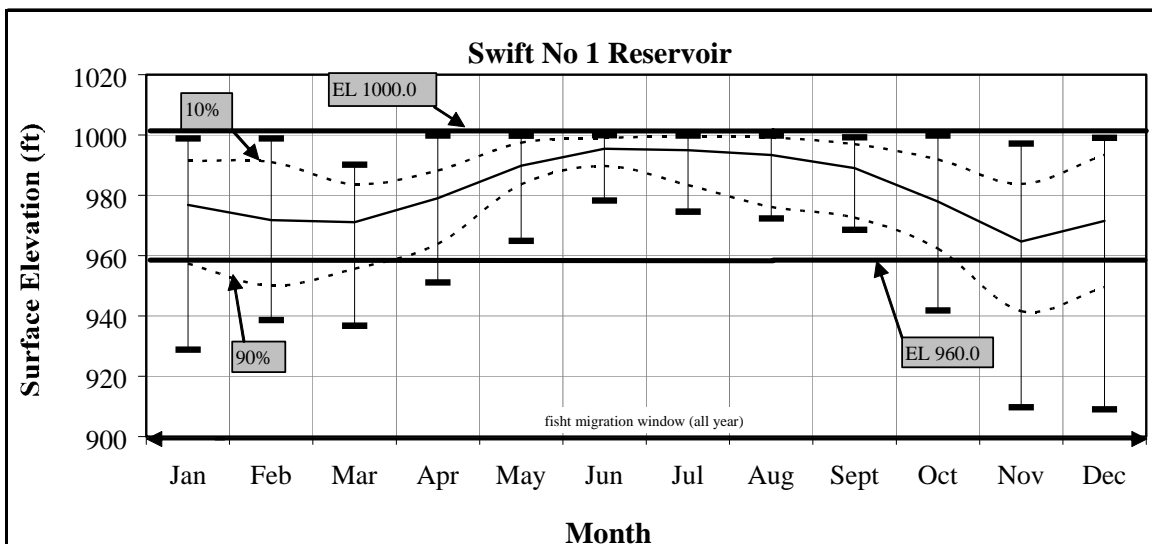

Figure 2.2-10. Swift Reservoir elevations (January 1, 1989 through December 19, 2000) and upstream fish migration timing.

Swift Reservoir is drawn down 58 feet (to Elevation 942.0) every five years for FERC mandated spillway gate inspections, typically during the low flow months when the reservoir is dropping (from September through November). The duration of the inspection drawdown varies from 2-hours to 2-weeks, and this period could be managed to accommodate fish passage to the extent possible.

The low elevation of 960.0 proposed for the Swift project upstream passage fluctuation will allow for upstream passage for nearly all of the 90 percent exceedence elevation values, other than the O&M drawdowns. As mentioned for the other projects, release of upstream adults can be accommodated during periods of extreme drawdown through backup trap-and-haul facilities, or alternate release facilities such as slides as described for Merwin and Yale.

2.2.6 Swift Reservoir and Tailwater Design Values for Downstream Passage

Table 2.2-6 summarizes the proposed tailwater and reservoir values for the design of downstream passage facilities at the Swift No. 1 and Swift No. 2 projects. Figures 2.2-11 and 2.2-12 illustrate these proposed design elevations relative to the tailwater and reservoir historic elevations.

Table 2.2-6. Downstream passage design elevations for the Swift No. 1 and Swift No. 2 projects.

	High Elevation	Low Elevation	Fluctuation (ft)
Swift Reservoir	1000.0	960.0	40.0
Swift No. 1 Tailwater (no curve)	604.0	602.0	2.0
Swift No 2 Tailwater	490	474.0	16.0

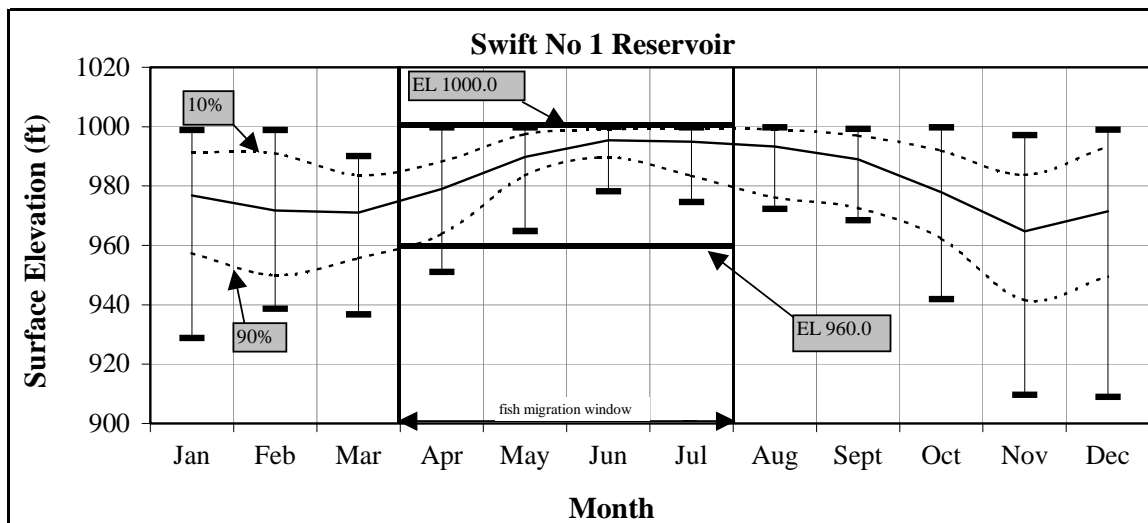

Figure 2.2-11. Swift Reservoir elevations (January 1, 1989 through December 19, 2000) and downstream fish migration timing.

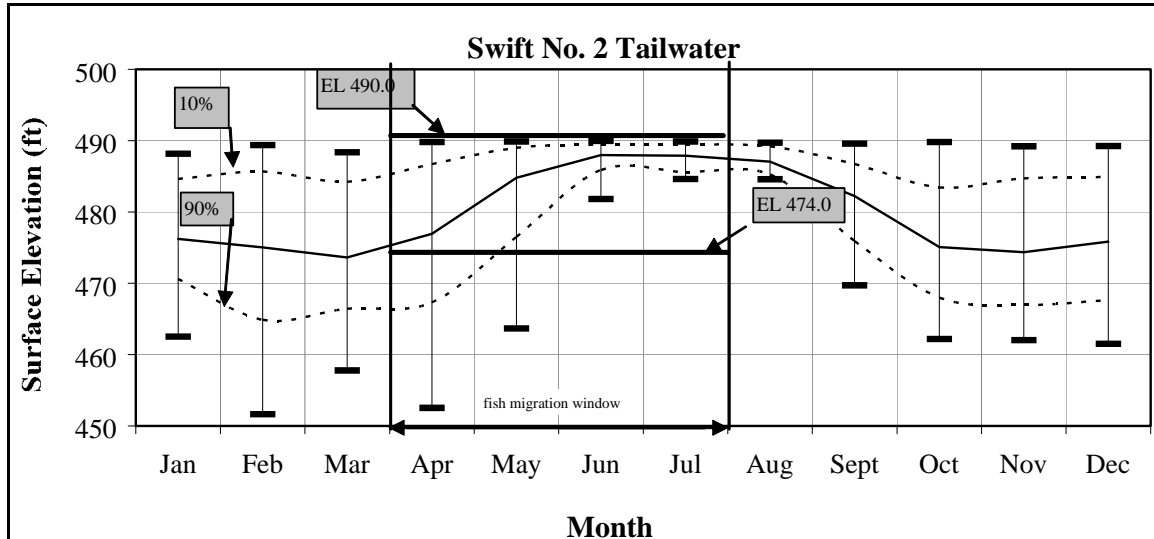

Figure 2.2-12. Swift No. 2 tailwater elevations (January 1, 1989 through December 19, 2000) and downstream fish migration timing.

2.3 DESIGN FLOWS

The Phase 1 report identified 10 percent and 90 percent exceedence flows as the basis for examining fish passage facilities. Similar to the reservoir elevations, the design flows have been refined to better reflect conditions during the anticipated fish migration periods.

Upstream passage design flows would be controlled by the higher winter flows, as fish would migrate throughout this entire season. The 90 percent exceedence flow in the highest flow months represents the upper bounding flow case.

The high design flow for downstream passage is dependent on how early the outmigration period begins each spring. For the purposes of analysis, it is assumed that downstream passage facilities would operate at a minimum from April 1st until the end of June or July.

Table 2.3-1 summarizes upstream and downstream limiting design flows for each project. This information was developed from the flow exceedence curves provided in the Phase 1 report as Figures 3.2-1 through 3.2-3.

Table 2.3-1. Design flow summary for passage facilities.

	Upstream Passage Design Flow (cfs)	Powerhouse Capacity (cfs)	Downstream Passage Design Flow (cfs)
Merwin	11,100	11,470	9,200
Yale	8,300	9,760	7,900
Swift No. 2	7,800	8,000	6,200
Swift No. 1	7,800	9,120	6,200

2.4 OPERATIONAL CONSIDERATIONS

It is common with hydroelectric facilities to expect some operational constraints to be imposed on fish passage facilities by the hydroelectric generation and flood management operations. It is also generally accepted that the reservoir fluctuations impose the greatest challenge when designing fish passage facilities.

As described in Section 2.1, fish passage facilities have been developed to operate most efficiently over a defined and more limited reservoir fluctuation than described in the Phase 1 report. It is also generally true that flood management and public safety concerns are often the controlling factor when examining limits to project operations. Flood management and associated pool levels are described in Section 11 of this technical report. Additionally, PacifiCorp is currently developing a project operational model that will allow comparison of various flood management alternatives and their impact on current operations.

For the purposes of analyzing and comparing fish passage alternatives, the design flow, reservoir fluctuation, and project operation information developed to date is expected to be sufficient. Furthermore, facilities are discussed where applicable to enhance performance of some fish passage facilities. It is expected that additional discussion to refine design elevations, project operations, and design flows will continue throughout the relicensing process.

PacifiCorp and Cowlitz PUD have stated a strong desire to maintain the existing operational flexibility of the overall Lewis River basin projects. Furthermore, Cowlitz PUD has stated its intention to continue operation with existing flows. To this end, this report identifies facilities that can accommodate these goals. Where clear conflicts with these goals are apparent, they are so noted.

3.0 FISH PASSAGE SYSTEM DEVELOPMENT

3.1 SYSTEM GOALS

As described in the Phase 1 report (PacifiCorp and Cowlitz PUD 2001), a clear understanding of basin goals is necessary for the design of specific fish passage facilities. Three broad basin goals were identified by the ARG that could require the construction of fish passage facilities for the Lewis River Projects:

- Reconnect fish habitat and fish populations throughout the basin.
- Reintroduce anadromous salmon into the upper basin.
- Protect and enhance bull trout populations.

Numerous ideas have been brought forward by ARG participants since the Phase 1 report publication in July 2001; however, no consensus has been reached on more specific basin goals. In order to develop and compare fish passage facilities, 7 potential fish passage systems intended to address the full spectrum of basin fisheries goals are presented in this section.

Similar to the 5 systems presented in the Phase 1 report, the 7 passage systems described in this document are not meant to be exclusive. Facilities described for each system can be mixed and matched in a number of ways to meet any combination of basin fisheries goals. The following section provides a brief description of the goals for each system, and a graphic representation of the system components relative to the overall basin.

3.2 SYSTEM ALTERNATIVES

The following sections describe the 7 fish passage systems:

1. Volitional Passage with Criteria Screens
2. Volitional Passage with Surface Collection
3. Fish Lifts Upstream, Surface Collectors Downstream
4. Fish Lifts Upstream, Surface Collectors Downstream with Trucking Facilities
5. Trap-and-Haul to Upper Swift with Surface Collectors
6. Trap-and-Haul to Upper Swift with Screens (bypassing Merwin and Yale)
7. Resident Trap-and-Haul (no anadromous reintroduction).

This page intentionally blank.

3.2.1 System 1: Volitional Passage with Criteria Screens

System 1 (Figure 3.2-1) relies on volitional adult and juvenile fish passage facilities to reconnect fish habitat and populations throughout the upper Lewis River basin. Upstream passage facilities would use fish ladders at each dam. Downstream passage facilities would use criteria screens with sub-sampling facilities at each dam. This system is designed to achieve all 3 basin goals.

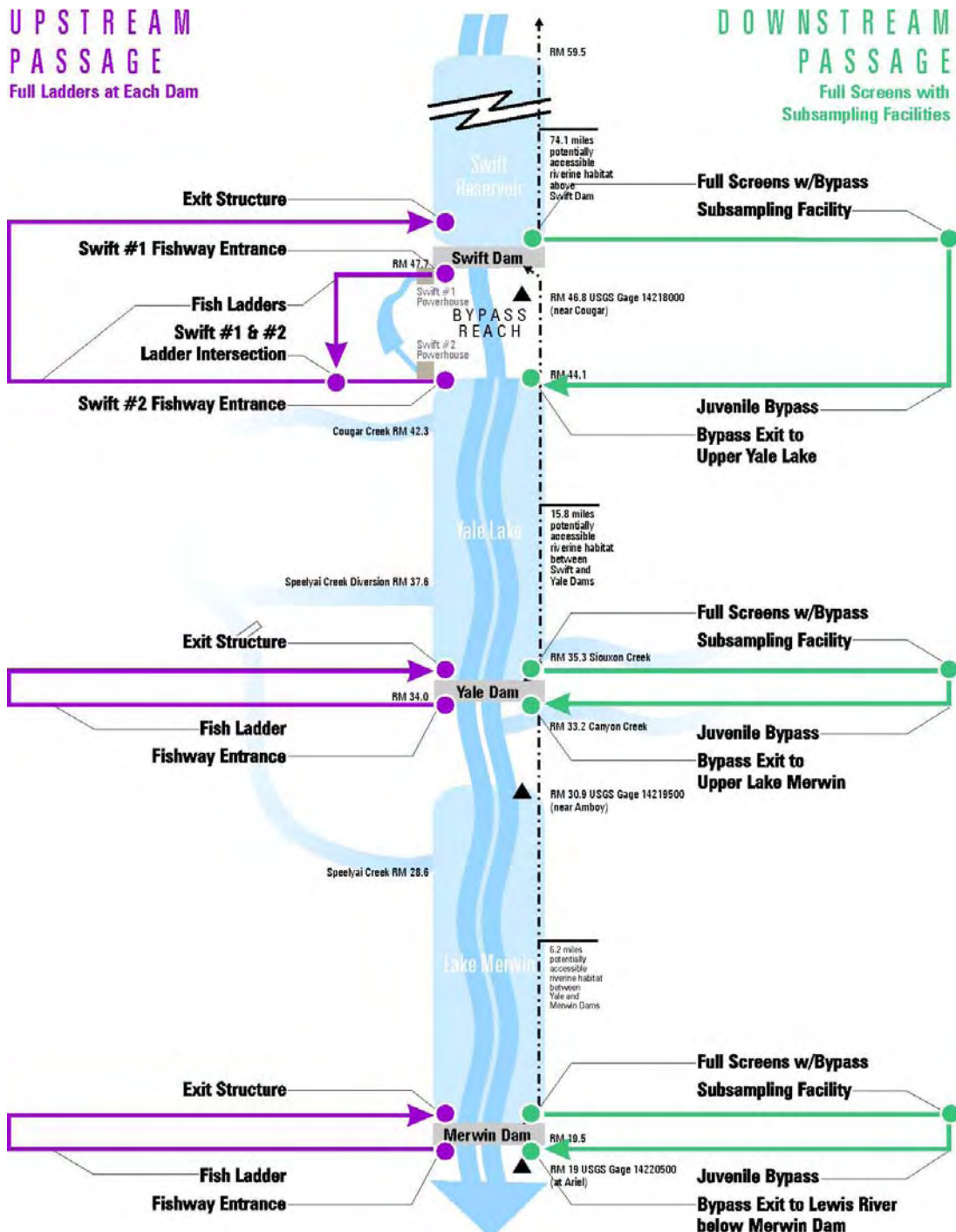

Figure 3.2-1. Volitional passage with criteria screens.

This page intentionally blank.

3.2.2 System 2: Volitional Passage with Surface Collectors

System 2 (Figure 3.2-2) relies on volitional adult and juvenile fish passage facilities to reconnect fish habitat and populations throughout the upper Lewis River Basin. Upstream passage facilities would use fish ladders at each dam. Downstream passage facilities would use surface collectors with sub-sampling facilities at each dam. This system is designed to achieve all 3 basin goals.

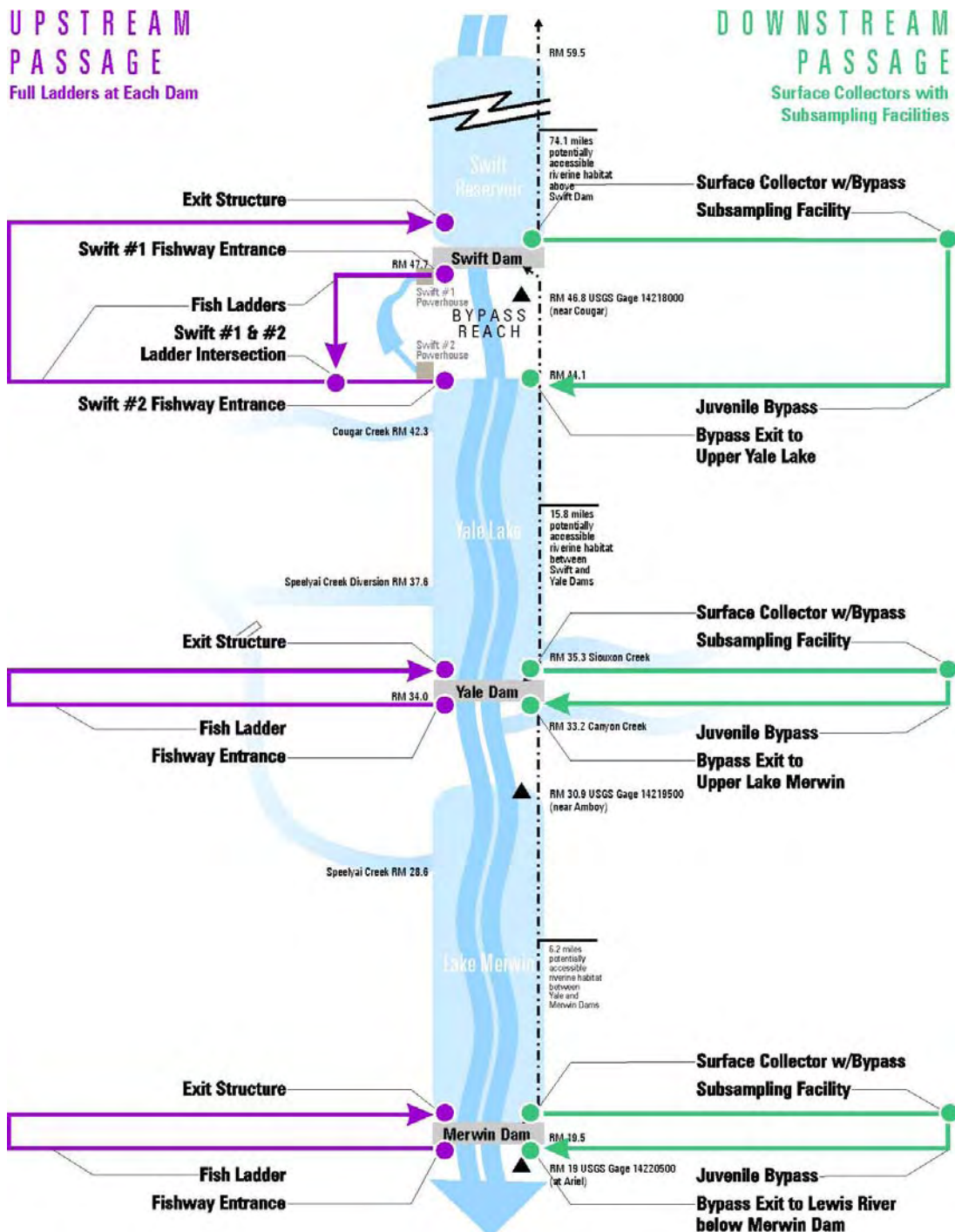

Figure 3.2-2. Volitional upstream passage with downstream surface collectors.

This page intentionally blank.

3.2.3 System 3: Fish Lifts Upstream, Surface Collectors Downstream

System 3 (Figure 3.2-3) is similar in approach to System 2, except that upstream fish lift facilities would be used in place of fish ladders to facilitate the upstream passage of adults. This system is designed to achieve all 3 basin goals.

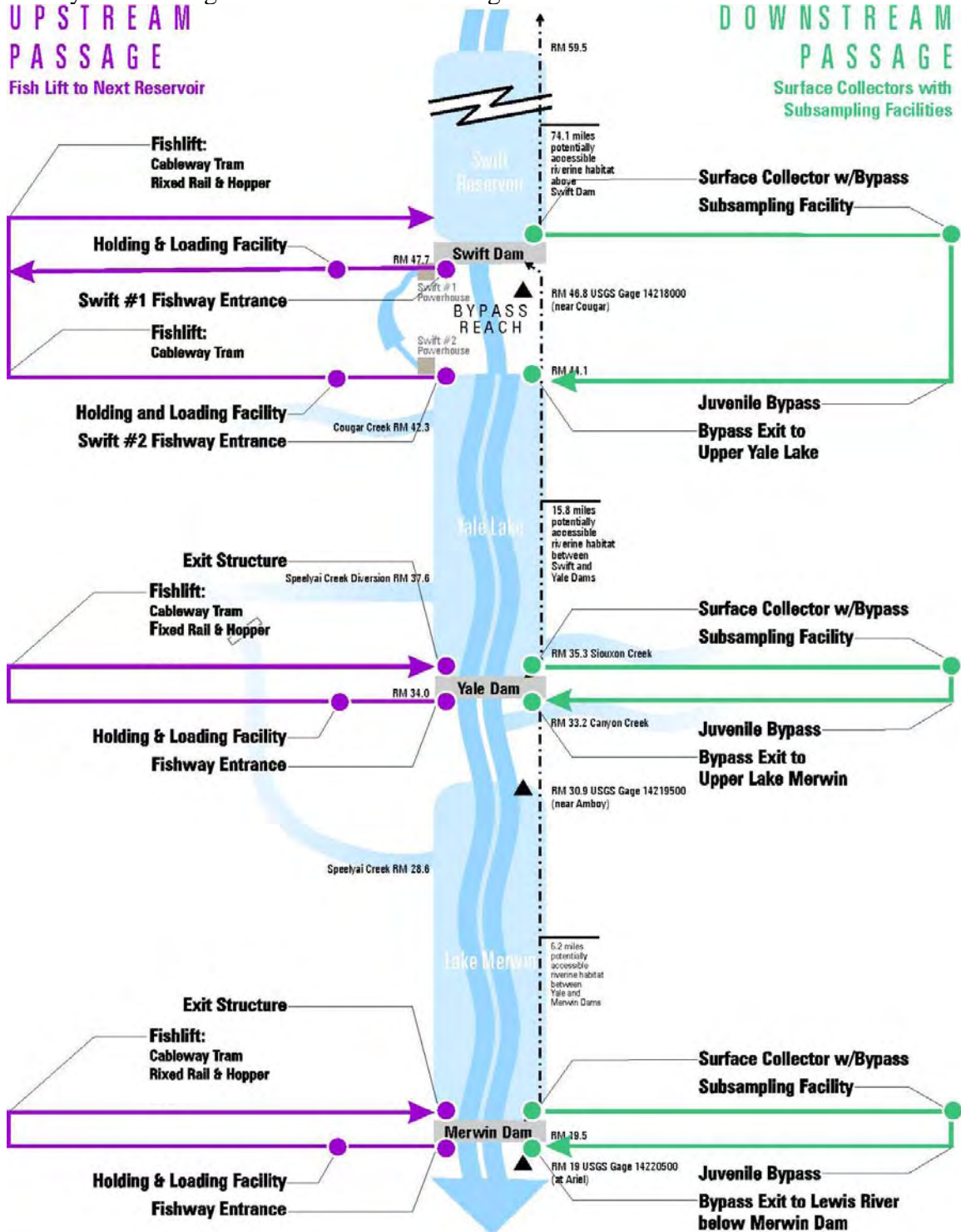

Figure 3.2-3. Volitional upstream passage with downstream surface collectors.

This page intentionally blank.

3.2.4 System 4: Fish Lifts Upstream, Surface Collectors Downstream with Trucking Facilities

System 4 (Figure 3.2-4) is similar in approach to System 3 except that downstream fish passage facilities would include trucking facilities to allow adaptive management to bypass outmigrants around the reservoir. This system is designed to achieve all 3 basin goals.

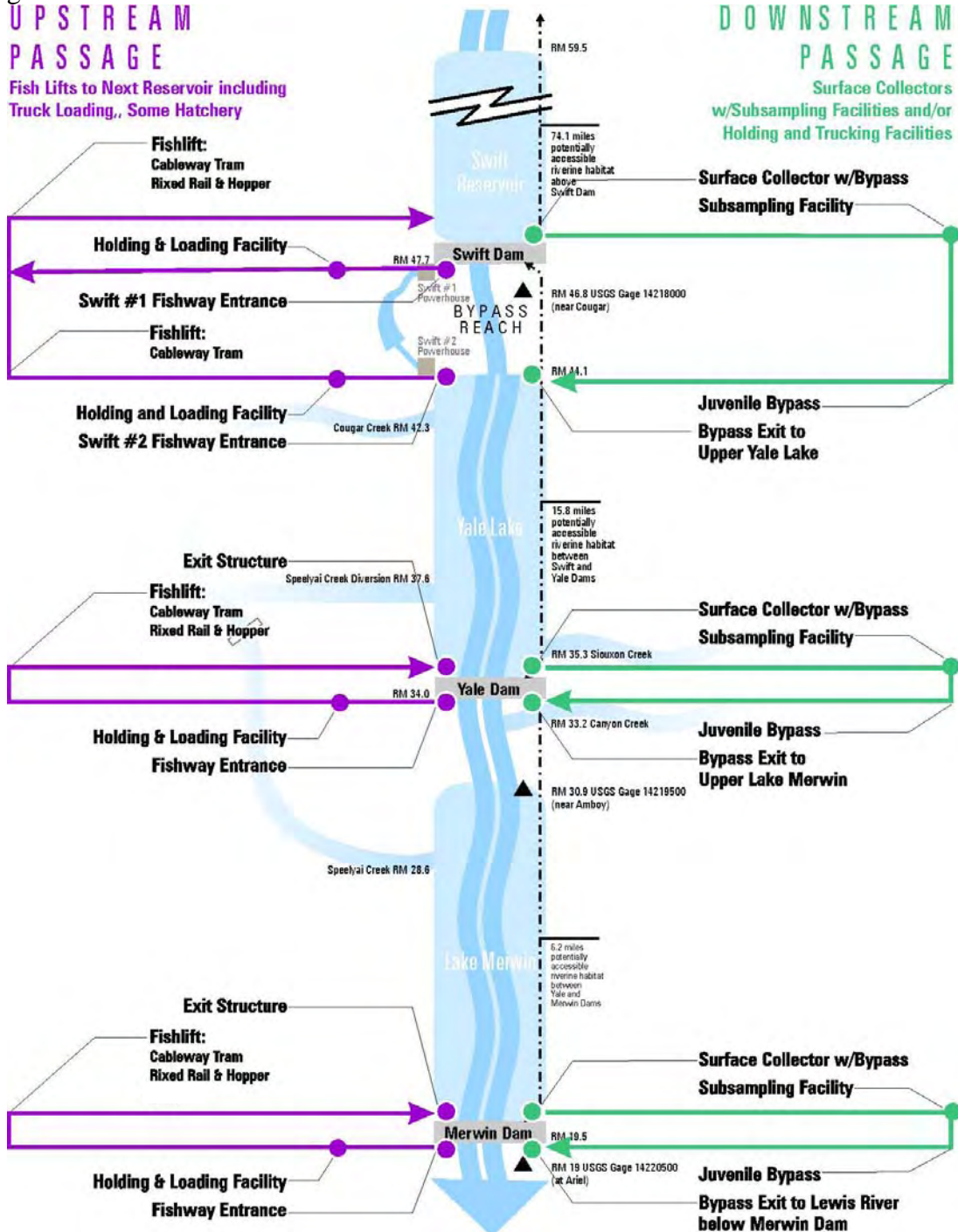

Figure 3.2-4. Fish lifts upstream, surface collectors downstream with trucking facilities.

This page intentionally blank.

3.2.5 System 5: Trap-and-Haul to Upper Swift with Surface Collectors

The objective of System 5 (Figure 3.2-5) is to meet the basin goal to reintroduce anadromous salmon into the upper Lewis River basin. This system would use both upstream and downstream trap-and-haul facilities, bypassing both Merwin and Yale reservoirs.

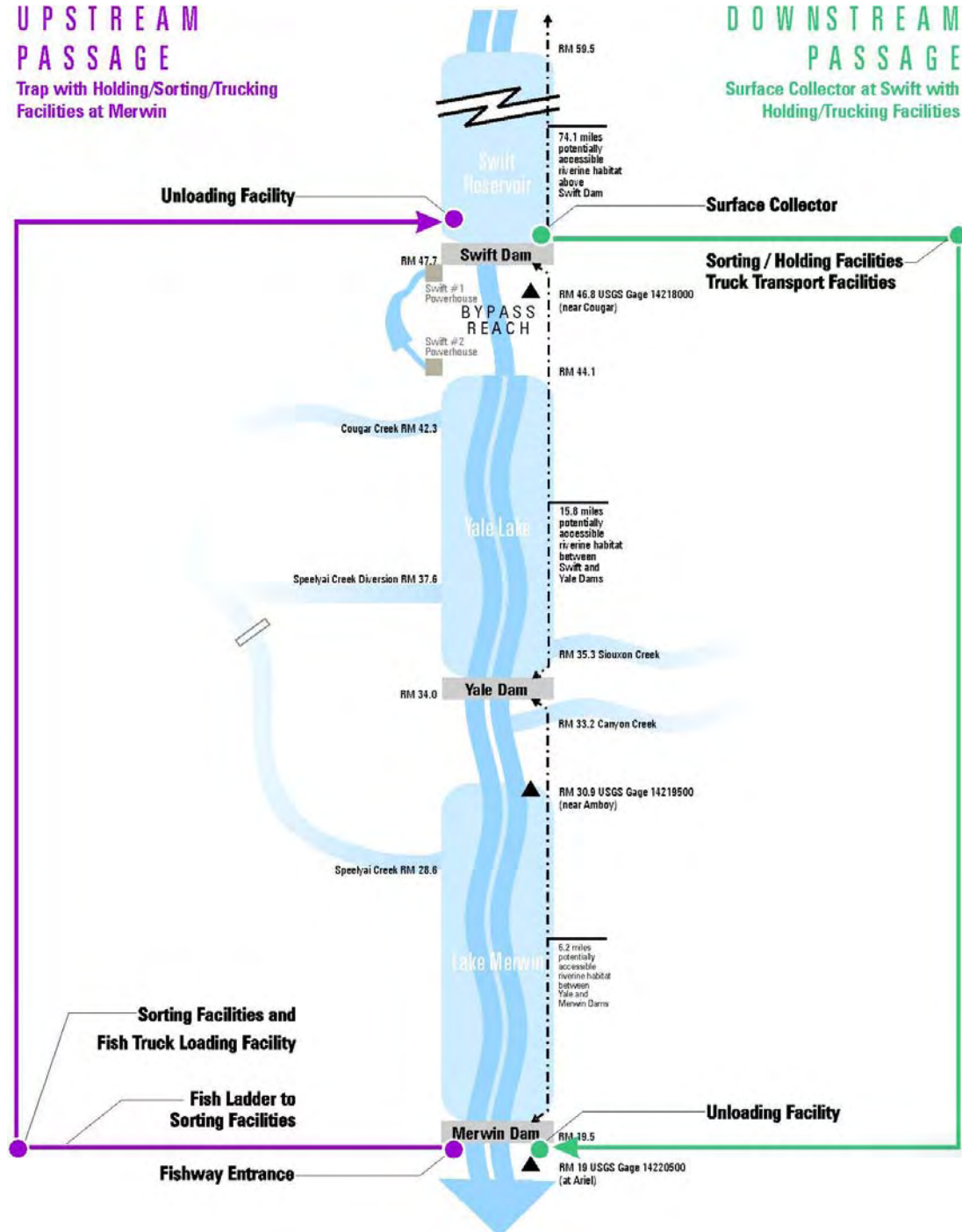

Figure 3.2-5. Trap-and-haul to upper Swift with surface collectors downstream.

This page intentionally blank.

3.2.6 System 6: Trap-and-Haul to Upper Swift with Screens (bypass Merwin and Yale)

The approach for System 6 (Figure 3.2-6) is similar to System 5 except downstream passage would use criteria fish screens in place of surface collectors.

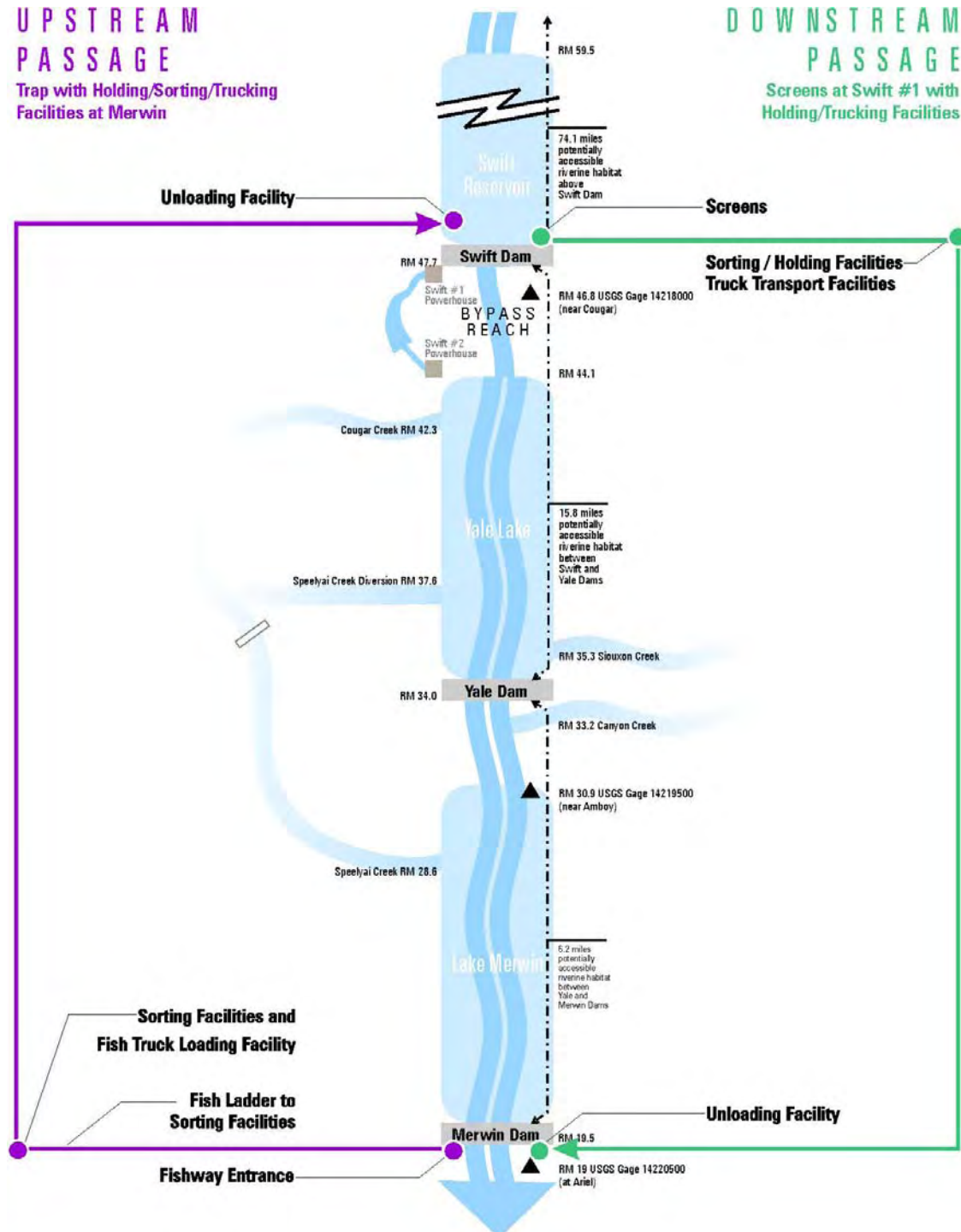

Figure 3.2-6. Trap-and-haul to upper Swift with screens (bypassing Merwin and Yale).

This page intentionally blank.

3.2.7 System 7: Resident Trap-and-Haul (no anadromous reintroduction)

The objective of System 7 (Figure 3.2-7) is to meet the basin goal to protect and enhance bull trout populations. The approach assumes that connecting the reaches, below, within and above the projects, and reducing entrainment mortality best achieves protection for bull trout.

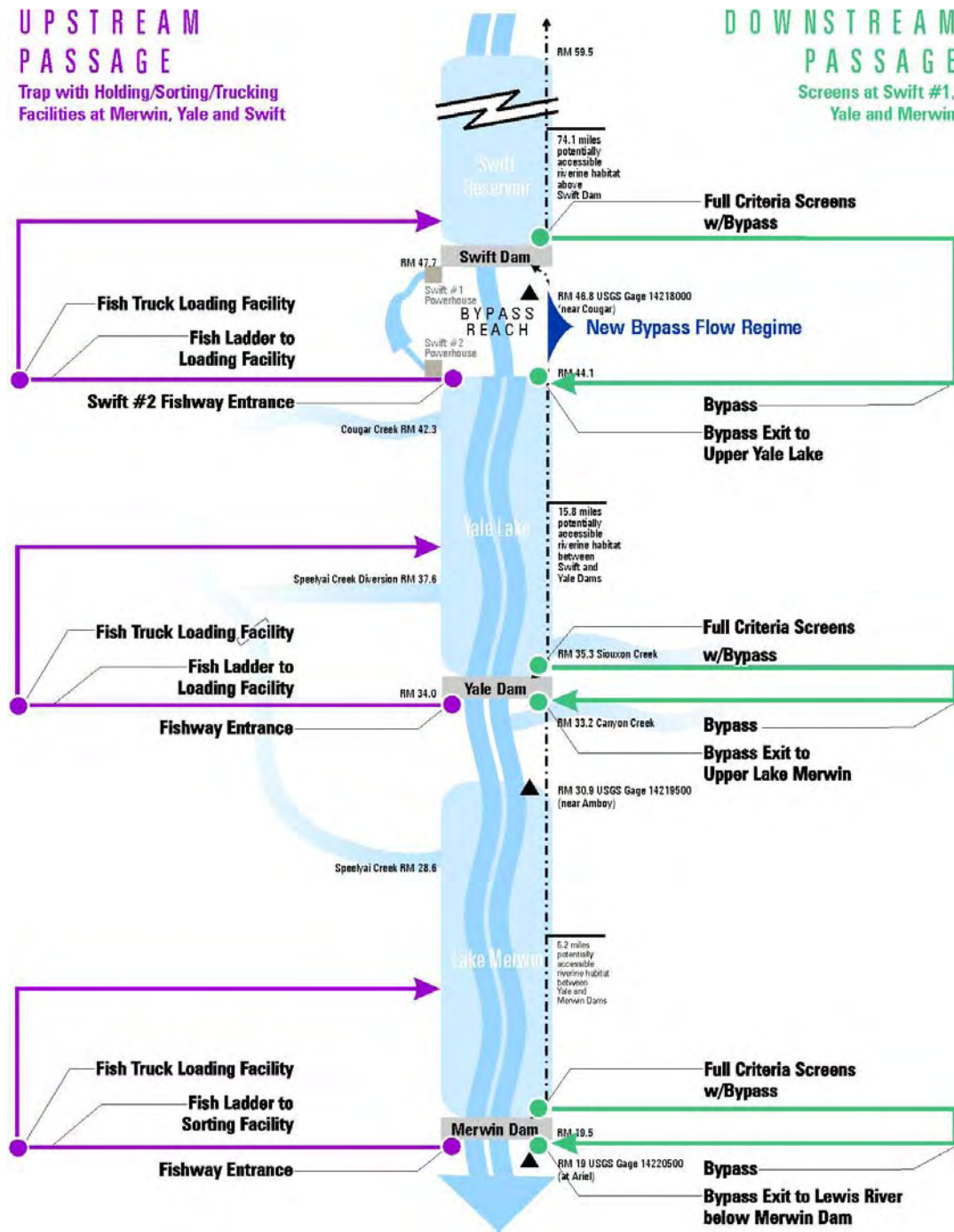

Figure 3.2-7. Resident trap-and-haul (no anadromous reintroduction).

This page intentionally blank.

3.3 DISCUSSION

As stated in the Phase 1 report, the ultimate biological performance of each passage system described above will not be known until the system has been designed, constructed and biologically evaluated. Obviously, decisions must be made about which system and corresponding facilities would have the highest probability of successfully meeting basin goals. In order to compare the predicted biological performance of the 7 systems, a set of draft working assumptions have been developed to help quantify estimates for probable juvenile and adult survival rates and travel times through project reservoirs, turbines, ladders, juvenile collection systems, and trap-and-haul facilities. These assumptions were developed based on a review of the existing fish passage literature and by technical staff from the National Marine Fisheries Service (NMFS), WDFW, the U.S. Fish and Wildlife Service (USFWS), and the 10,000 Years Institute with Steward and Associates.

A complete list and description of the working assumptions can be found in the Fish Passage Working Notebook (PacifiCorp and Cowlitz PUD 2000). Additionally, ARG members have provided a document describing a set of assumptions (10,000 Years Institute 2001). Work by the ARG to refine assumptions on specific facility performance and ultimate system performance is under way through the LRFPM. Tables 3.3-1 and 3.3-2 (first presented in the Phase 1 report) are included to emphasize the importance of using a more defined set of data to analyze the overall systems. These values have not been agreed to by ARG members, and new values are still anticipated prior to final settlement agreement.

Table 3.3-1. Juvenile survival estimates for passage through reservoirs, turbines and bypass systems.

	Expected	Optimistic	Pessimistic	10,000 Years/ Steward
Coho Juvenile Migrants Per Reservoir Survival Value	70%	85%	30%	92%
Steelhead Juvenile Migrants Per Reservoir Survival Value	80%	95%	65%	--
Spring Chinook Juvenile Migrants Per Reservoir Survival Value	28%	70%	10%	--
Bull Trout Juvenile Migrants Per Reservoir Survival Value	Yet to be Determined	Yet to be Determined	Yet to be Determined	--
Turbine Survival Value (Includes tailrace survival / predation)	75%	85%	40%	70%
FCE (Fish Collection Efficiency) – Partial Screening	75%	85%	40%	70%
FCE – Total exclusionary screening	100%	100%	100%	--
Bypass System	97%	99%	95%	98%
Tagging	98%	99%	97%	--
Truck transport	97%	98%	97%	98%
Juvenile survival through multiple bypass systems	50%	Yet to be Determined	Yet to be Determined	--

Table 3.3-2. Adult survival estimate for volitional and trap-and-haul facilities.

	Expected	Optimistic	Pessimistic	10,000 Years / Steward
Ladder Survival	93.5%	97%	80%	93% ¹
Trap & Haul	93.5%	97%	90%	94% ¹

¹ Combines passage and entrance efficiency survival.

4.0 UPSTREAM PASSAGE FACILITIES

4.1 PHASE 2 FACILITY INFORMATION

Upstream passage facilities designed to meet the needs of by the 7 systems are provided in this section. Narrative descriptions of each facility, conceptual drawings, and a reference to the overall passage system provide:

- an understanding of how each concept would operate as a fully functioning facility,
- an overall scale and feel of the facility relative to the existing hydroelectric developments,
- an illustration of how various facility components would be connected,
- information to assist decision makers in estimating future biological performance, and impacts to the existing project,
- a basis for developing cost estimates for each facility design, and
- an understanding of how each facility component would fit into an overall fish passage system.

Most of these facilities were first described in the Phase 1 report. Work performed since July of 2001 has focused on adjustments to the Phase 1 facility designs reflecting (1) comments received and discussed by the ARG; (2) the more refined reservoir fluctuation criteria described in Section 2; (3) development of new system and facility alternatives; and (4) development of cost estimates. Much of the descriptive information originally presented in the Phase 1 Report will be repeated in Sections 4 and 5, although design criteria will not be repeated unless it has been modified. Facility descriptions in this Phase 2 report will supercede the Phase 1 report information.

Facilities have been developed with a building block approach to allow the reader to mix and match facilities to address various system goals. A guide to where various facilities would be located in the basin is provided in Figure 4.1-1. The naming convention for each alternative provides a reference to the dam, defines if the alternative provides upstream or downstream passage, and designates an alternative number. For example, Drawing/Alternative MU-4 designates “Merwin Upstream Facility, Alternative 4.” upstream passage facility alternatives that have been illustrated are identified on Figure 4.1-1.

Upstream fish passage facility alternatives are presented in the order that fish would encounter the projects: downstream to upstream. The conceptual drawings are the most efficient means to communicate the design concept; therefore, the drawing sets have been prepared as nearly stand-alone components that communicate the design intent and primary criteria. Supporting text in this section provides additional information on the design criteria, design intent and any notable constraints for specific designs.

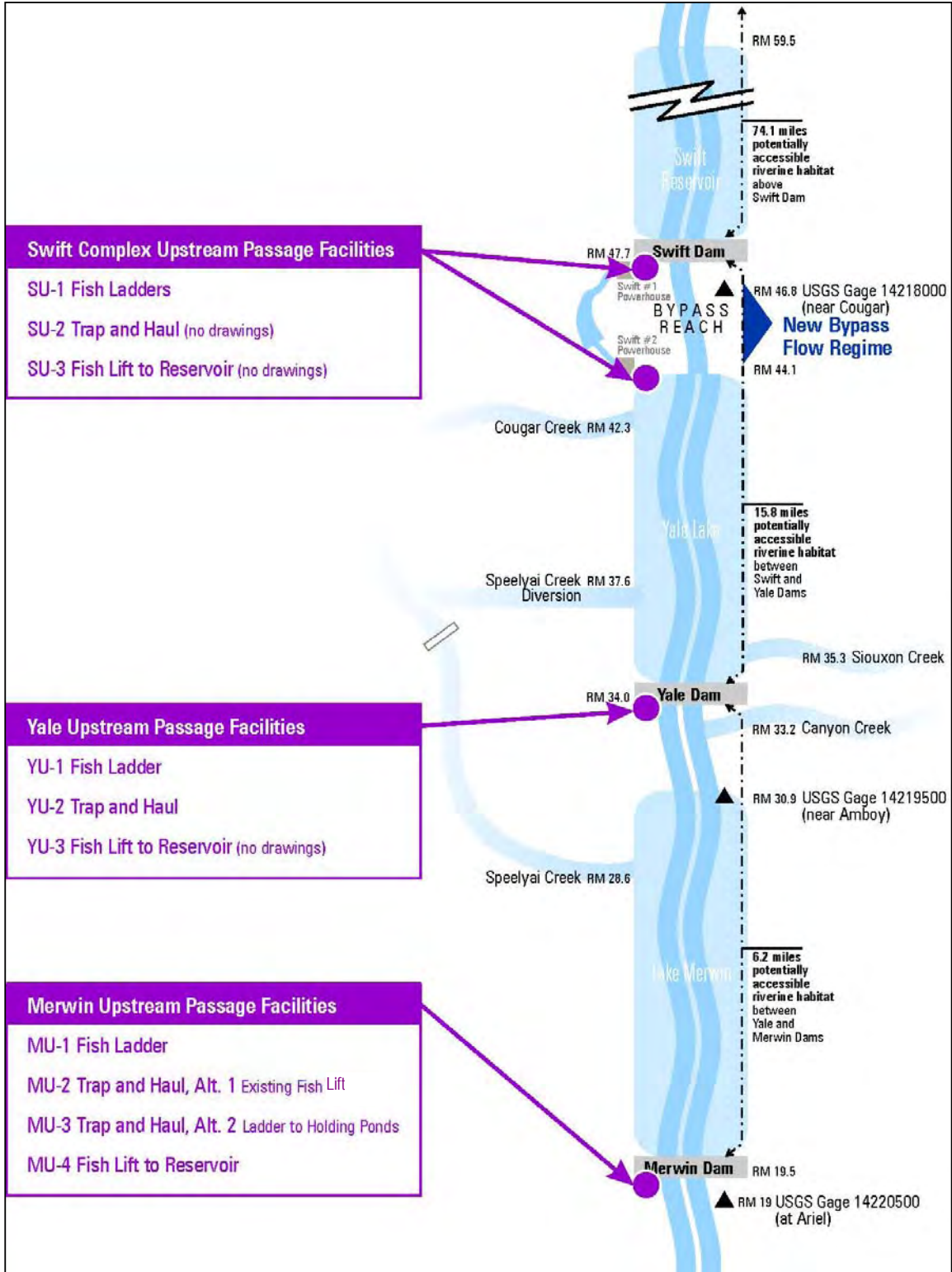

Figure 4.1-1. Key to Upstream Passage Facilities.

This page intentionally blank.

Conceptual facility drawings are located under Tab A, with naming conventions that match Figure 4.1-1. To reduce the number of overall drawings and more clearly communicate new information, drawings and ideas developed in the early numbered drawings are referenced in later drawings where duplication of ideas occurs. Concepts that could be equally applied at each dam are generally only illustrated once to avoid duplication. It is important to note that individual design features illustrated on one alternative can be utilized for other sites or concepts. For alternatives where drawings are not provided (identified in Figure 4.1-1), the concepts are referenced to other facilities.

4.2 REFERENCE TO COST INFORMATION

There are often multiple solutions to each fish passage facility challenge. Because the concepts studied in this document will be used primarily for planning and to guide decisions on future development, designs have been kept simple to better communicate their intent. They have been developed adequately to prepare meaningful estimates of expected performance and construction costs. It is expected that some level of design optimization, based on ARG and other input, would be required prior to implementing any of the conceptual designs.

Additional information is provided in Section 6 regarding the facility costs. Each major component of the upstream fish passage facilities is referenced to a cost value in Section 6. The order of presentation of the various facility components has been revised from the Phase 1 report to correlate facilities with the cost summary table.

4.3 MERWIN DAM UPSTREAM ALTERNATIVES

The target species for upstream passage at Merwin Dam include:

- Spring Chinook
- Coho Salmon
- Summer Steelhead

- Winter Steelhead
- Chum Salmon
- Sea-Run Cutthroat

The following species are not specifically considered for upstream passage at Merwin Dam. Many of the facilities identified would be effective for some of these species, depending on how and when they would be operated.

- Kokanee
- Bull Trout
- Pacific Lamprey

Fall Chinook will continue to arrive at Merwin, and will need to be collected for brood at the hatchery, unless current management of the stock is changed.

4.3.1 MU-1, Merwin Dam Fish Ladder

A fish ladder alternative for Merwin Dam is shown on Drawings MU-1.1 through MU-1.8. Fish loading criteria considered in the design and layout of the ladder is presented in the Phase 1 report. This section describes the ladder and integral components starting from the ladder entrance and ending at the exit structure. Costs for these components are noted in Section 6.

4.3.1.1 Draft Tube Configuration

Comments on the Phase 1 report requested examination of the draft tubes to determine the potential for fish entrainment or injury (Tab C, Appendix A). Figure 4.3-1 provides a plan, front elevation, and section view through the draft tubes. The Merwin turbines are 45 MW vertical Francis units, with a maximum flow of 3,790 cfs for Units 1 and 2, and 3,890 for Unit 3. The centerline of the runner elevation is at elevation 60.0 feet msl, which is above the high and low design tailwater elevations of 54.0 and 46.0 feet respectively. The turbines operate at 120 rpm.

Table 4.3-1 provides a summary of calculated mean velocities throughout the tailrace of Units 1 and 2, taken at the 6 sections as shown in Figure 4.3-1 (Section A-A). Table 4.3-2 provides similar information for Unit 3. The mean velocity is calculated as the total flow divided by the cross sectional area. This method provides a good indicator of the overall water velocity; however, there will be local boundary effects which result in lower velocities along the concrete walls, as well as higher velocities throughout the water column due to turbulence and flow instability.

Table 4.3-1. Calculated mean velocities at Merwin tailrace, Units 1 & 2.

Gate Setting	Unit Flow (cfs)	Velocity at Sections Through Tailrace (fps)					
		V ₁ (face)	V ₂	V ₃	V ₄	V ₅	V ₆
Max	3,790	10.7	13.4	14.5	16.6	39.9	31.8
¾ Gate	2,905	8.2	10.3	11.1	12.7	30.6	24.4
½ Gate	2,021	5.7	7.1	7.7	8.9	21.3	17.0
Min	1,137	3.2	4.0	4.4	5.0	12.0	9.6

Table 4.3-2. Calculated mean velocities at Merwin tailrace, Unit 3.

Gate Setting	Unit Flow (cfs)	Velocity at Sections Through Tailrace (fps)					
		V ₁ (face)	V ₂	V ₃	V ₄	V ₅	V ₆
Max	3,890	11.1	13.7	14.9	17.1	41.0	32.7
¾ Gate	2,983	8.4	10.5	11.4	13.1	31.4	25.1
½ Gate	2,075	5.9	7.3	7.9	9.1	21.8	17.4
Min	1,167	3.3	4.1	4.5	5.1	12.3	9.8

Assuming sustained swimming speeds of 10 to 15 feet per second (fps), and darting speeds ranging from 20 to 26 fps for the target species (Bell 1986), it could be generalized

that mean draft tube velocities at the face of the powerhouse are less than the swimming capabilities of the upmigrating adults.

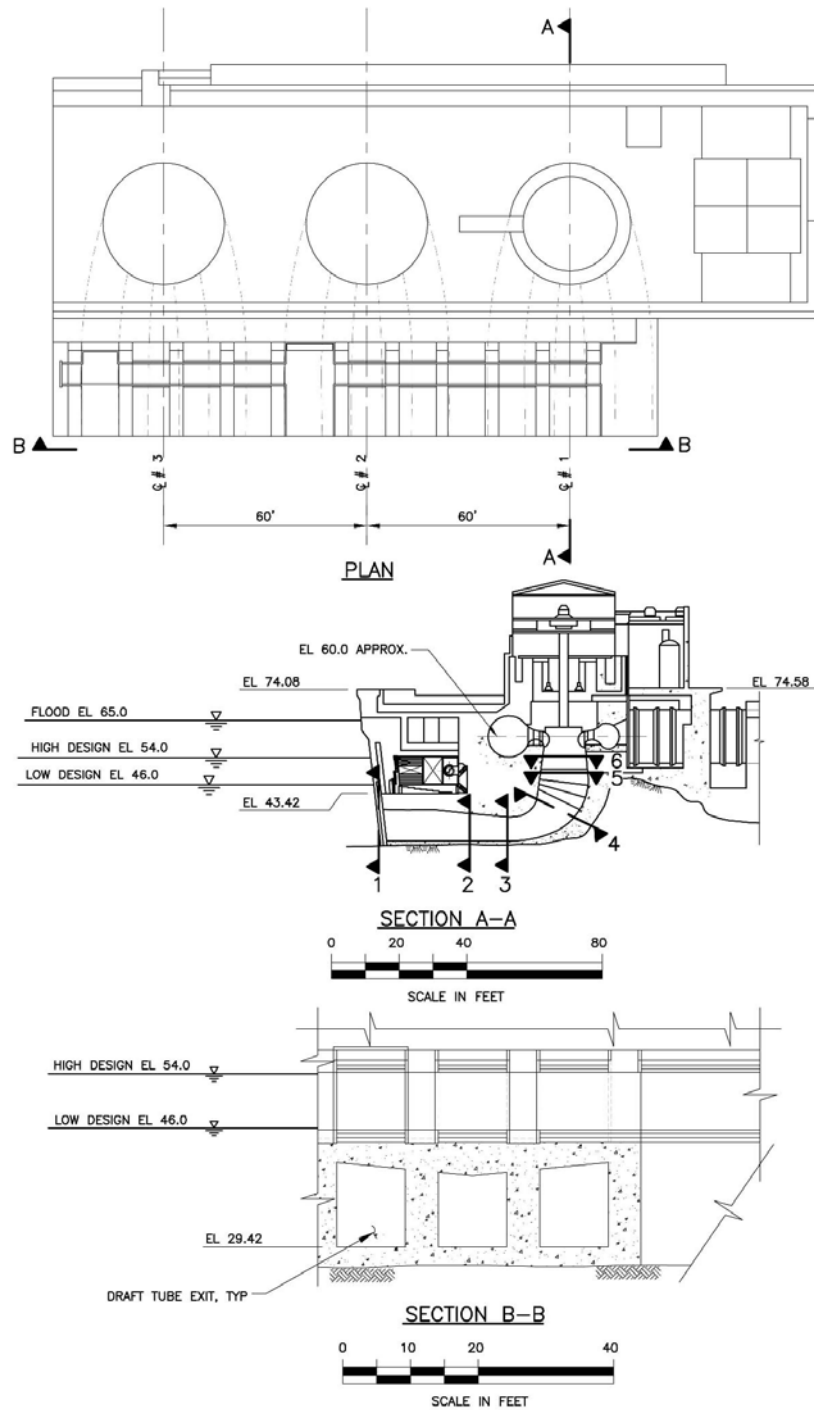

Figure 4.3-1. Merwin Dam draft tube configuration.

Quantifying existing velocity fields as shown in the above tables illustrates that the velocities alone will not prevent fish from entering the draft tubes at full turbine flow, or at reduced operational flows. The geometry of the draft tubes creates a higher velocity that fish would sense as they enter the face of the draft tube and move closer to the turbine runner. This increasing velocity gradient would make it difficult for fish to actually contact the runner at all but the minimum operational flows. During the lower flows, the tailwater elevation would likely be below the runners, and the flow would be turbulent in this area due to gate throttling.

This velocity analysis is helpful to evaluate whether continued access to the draft tubes could harm upstream migrating adults. Given the high velocities at the upstream end of the draft tubes relative to swimming capability, it appears that fish would be prevented from striking the turbine runners under all but the lowest operating conditions. Because the runners are also above the tailwater elevations, it is unlikely that fish could be injured by a runner strike, except possibly during unit start-up from a non-operating condition. Under this scenario, if fish were holding in the draft tube area in a non-operating unit, it is conceivable that they could be attracted to the initial velocities of unit start-up, although the runners would be above the tailwater in this condition. Even if this were a potential for injury, operation could be managed to minimize cold unit starts to reduce this potential.

While runner strike appears unlikely with the Merwin units, the velocity analysis alone cannot determine whether fish could be injured or disoriented by the velocities in the draft tubes. There is always potential for fish to lose swimming direction and be tossed into draft tube walls. Turbines by nature are designed to minimize turbulence and high shear flows; however, these flow conditions can never be avoided completely for all operating conditions.

While the velocity analysis shows that draft tube barriers may keep fish from entering the Merwin draft tubes, it is not clear that such a barrier would benefit upstream passage facilities or reduce injury. In fact, placing a bar rack across the opening could impinge outmigrating anadromous fish or resident fish that may pass through the turbine. No tailrace or draft tube barriers are proposed, nor are barrier cost estimates developed for the Merwin powerhouse in this report.

4.3.1.2 Fish Ladder Entrance

The ladder entrance alternative shown on Drawings MU-1.5 and MU-1.6 utilizes the existing fish lift entrance located in the tailrace of the Merwin powerhouse. The fish lift entrance was originally designed in the 1950s to accommodate 3 weir entrances, one per unit. This facility underwent a major reconstruction by PacifiCorp in the 1980s, and continued improvements have been made through 1997. The fish trap entrance is currently configured for a single entrance that operates at about 31 to 33 cfs, with a maximum capacity of 45 cfs. Attraction water for the entrance is primarily supplied by pumping it from the tailrace. A pipeline discharging Merwin Hatchery effluent is used occasionally to attract the fish or as a back-up system. There is also a back-up system

that uses water from the penstock of the house unit in the event that the pump fails and fish are in the trap.

Comments on the Phase 1 report suggested the need for further analysis of the intake ladder entrance configuration, and better quantification of the existing intake capabilities (Tab C, Appendix A). Based on visual observation of fish entering the existing trap, and on total numbers of fish successfully transported by the trap facility, PacifiCorp believes that minor modifications to the existing ladder entrance will resolve noted deficiencies. A line item is provided in the cost table to increase the attraction flow from the current configuration of 33 cfs at the single entrance to approximately 100 cfs with 3 entrances. Additional comments regarding potential for improvement to the ladder entrance are provided in Section 4.3.2.

4.3.1.3 Fish Ladder Design

One of the largest challenges for the Merwin site is the height of the ladder. The ladder must operate from the lowest tailwater elevation of 47 to a reservoir level of 240 feet msl, for a total height of 193 feet. Comments received on the Phase 1 report concurred with the suggestion of a “Half Ice Harbor” ladder design. Typical sections of the Half Ice Harbor ladder are shown on Drawing MU-1.3. The required flow for this design is approximately 24 cfs. The ladder pool sizes would be 8 feet wide, 10 feet long and 5 feet deep, and each step would be designed to climb one vertical foot. As shown on Drawing MU-1.3, a 15-inch square orifice is located in the bottom of the overflow weir to allow fish that would rather migrate along the bottom (such as chum) a passage portal other than jumping over the weir. These dimensions result in a pool volume of 400 cubic feet.

Given the ladder’s height of nearly 200 feet, resting pools are recommended to allow extra volume and resting space to aid in the adult migrant’s climb. Combined turning and resting pools are provided at twice the regular pool volume, located every 12 vertical feet. Various sizes and locations are possible, but this assumption provides a reasonable starting point to begin the ladder layout.

Because the Half Ice Harbor design is a pool and weir type ladder, the primary ladder would be designed for a constant flow and water surface elevation. The ladder entrance and exit structures would be designed to accommodate the fluctuating reservoir and tailwater levels.

Drawing MU-1.1 provides an overview of the ladder routing, turning/resting pool locations, entrance and exit structures, ladder access, and other site constraints. As shown on Drawing MU-1.1, the ladder would begin at the existing Merwin fish lift entrance and follow the left bank (looking downstream) immediately downstream of the powerhouse. Sufficient ladder length is necessary in this steep, rock cliff area to gain enough elevation to cross the river. A ladder route leading to the reservoir along the left bank is less desirable than crossing the river and constructing it on the right bank due to limited construction access and the steepness of the left bank. Sections shown on Drawing MU-1.4 illustrate the steepness and difficult construction required to fit the ladder into the cliffs near the powerhouse.

The fish ladder bridge crossing is shown on the upstream side of the existing access bridge to avoid crossing the access road twice. This location is susceptible to infrequent but potentially severe spray from the spillway; the bridge is nearly inundated with spray during high spill events. In fact, the access bridge was once destroyed due to high spill. The fish ladder crossing shown in profile (Drawing MU-1.2) assumes the fish ladder bridge girders would be set at or above the elevation of the existing bridge. The spillway spray condition could be mitigated by (1) raising the fish ladder crossing higher than the existing bridge, (2) locating the crossing downstream of the bridge, or (3) placing a cover over the fish ladder in the areas susceptible to spray.

Following the river crossing, the fish ladder would switchback up the right bank of the river along an alignment intended to avoid Merwin headquarters, Merwin Village and Merwin Park, to an exit structure located outside the spillway and non-overflow section. An access road is shown along the full length of the ladder to allow inspection of the entire ladder. Security fencing or other measures would be necessary to deter poaching or vandalism of the ladder. A substantial cut section would be required for approximately 800 feet of the ladder, as shown on Profile Drawing MU-1.2, and Section C on Drawing MU-1.4. Excavations up to 60 feet deep would be required per the alignment shown. A cursory look at geologic mapping indicated that the majority of this cut would be through rock. Additional geotechnical studies would be required to refine the design.

The intent of layouts shown in this document is to communicate general feasibility and design features. Details such as design optimization and architectural treatments are beyond the scope of this document.

4.3.1.4 Fish Ladder Exit

A revised conceptual layout for a Merwin fish ladder exit structure is shown on Drawings MU-1.2, MU-1.7 and MU-1.8. The exit structure would be designed to accommodate fluctuation in reservoir elevation between 240 and 227 feet msl (13 feet of fluctuation). To avoid fallback into either of these flow fields, an exit location west of the non-overflow section was selected. Fish exiting a ladder at this location could follow the right bank of the reservoir, although no data are currently available to support this siting.

The exit structure concept shown provides a series of adjustable weirs, with a single exit along the right bank parallel to the existing shoreline. This approach, along with the reduced reservoir design elevations, decreased the size of the ladder exit structure over the Phase 1 ladder exit. The internal weirs would be automatically controlled, providing a maximum one-foot jump to the varying reservoir elevation.

4.3.2 MU-2, Merwin Dam Trap and Haul, Alt 1 – Existing Fish Lift

There are varying opinions regarding the need and means required to improve the existing Merwin Trap entrance. A line item cost to increase flows at the fishway entrance is provided as described in Section 4.3.1.2. Concerns regarding future improvements to the trap entrance should focus on the following parameters:

1. Effectiveness of the trap entrance for all required operational flows, tailwater levels, and project operational scenarios when upmigrating target species are present.
2. Efficiency and ease (lack of fish stress) for fish to move volitionally to the extent possible from the trap entrance to the trap's fish lift. Consider numbers of fish at peak and normal runs, and their ability to enter the trap under own volition or an efficient crowder system.
3. Size and operational efficiency to transport peak runs up the fish lift and transfer to transport facilities. Transport facilities described in this study for consideration include a truck loading station, a fish lift, and fish ladder alternatives.
4. Health and safety concerns for operating personnel. Any improvements to the existing trap should carefully evaluate and identify changes to improve operational health and safety issues to modern levels as required by OSHA and WISHA.

Alternative MU-2 presented in the Phase 1 report used the existing fish lift and reconstructed trap entrance, and relied on truck transport to take adult fish from the existing lift to a new fish handling facility for short-term holding, fish sorting and truck loading. Comments received on this concept expressed concern regarding the double handling of fish (lift to truck to sorting facility, sorting facility to truck to final destination.)

Drawing MU-2.1 illustrates a combination of the Phase 1 report concepts. This alternative would enlarge the existing fish lift, convey fish from the lift via a flume to a new sorting facility located along the left bank downstream of the powerhouse, and terminate with a facility to hold fish until they could be transported via truck their ultimate destination.

The existing trap transports from 60 to 80 fish per cycle into 1,000 gallon tanker trucks. Cycle time is about 10 to 15 minutes per load, allowing transport of about 240 to 480 adult fish per hour. The goal of enlarging the existing trap is to ease operational constraints in the current facility and improve worker safety.

A total of four 13.5-foot-diameter ponds, each with a capacity of about 690 cubic feet (~5,000 gallons) are shown for holding / transport ponds. A sorting facility is illustrated on Drawing MU-2.1. Additional detail is shown on Drawings MU-3.2 and MU-3.4. A holding pond would receive fish from the transport flume, then an operator would turn on a false weir to attract the fish to the sorting flume. Visual observation allows an operator to activate one of 4 automated gates that would route individual fish to one of the 4 tanks. An additional gate could be provided to route the fish into a sampling building. A flow of about 200 gpm per pond would be required. It could be pumped from the tailrace, gravity fed from the reservoir, and possibly reused from the hatchery effluent. Fish would then be loaded through a water-to-water transfer to the tanker trucks for transport upstream. Discharge facilities similar to a boat ramp would be required at each upper river or reservoir release site.

An alternate location for the fish handling facility could be provided at the Lewis River Hatchery, similar to the concept shown as MU-2 in the Phase 1 Report. This site may have the additional benefit of using existing holding ponds, should more short or long-term holding be desired. However, it would still require trucking from the fish trap, and would result in double handling of the fish.

4.3.3 MU-3, Merwin Dam Trap and Haul, Alt 2 – Ladder to Holding Ponds

The concept of Alternative MU-3 is to avoid double handling the fish from the existing fish elevator as required with MU-2. The concept shown on Drawings MU-3.1 through MU-3.4 illustrates use of the existing Merwin fishway entrance, directing fish into a new ladder similar to Alternative MU-1 that leads to a new fish handling facility. Fish would enter a short-term holding pond, then would jump over a false weir and be sorted and transported as described for Alternative MU-2. WDFW comments on this approach are provided in Appendix A, which primarily focused on the entrance conditions. These comments are addressed in Section 4.3.1.2.

The difficulty with this concept is the severely constrained site (as shown on Drawing MU-3.1), requiring a ladder to climb along the difficult left bank site near the powerhouse. It would extend from the low tailwater elevation of 47.0 msl to a holding pond water surface of about 126.0 msl, or 79 vertical feet. This elevation is nearly the same vertical gain as many of the Columbia River fish ladders.

Upon further investigation based on comments from the Phase 1 Report, it appears that the ladder height may be decreased to reduce the vertical lift required to access the sorting facility. For cost purposes, this approach would require substantially more rock excavation and site work. Because the concept shown on Drawing MU-3 is sound, this drawing has not been revised. Costs developed for the alternative will be appropriate for revised site layouts.

As mentioned in the Phase 1 report, the use of adult fish pumps, such as the Pescalator Archimedes screw-type fish pump, could substantially reduce the cost of site work required for this alternative. The Pescalator fish pump installed in 2001 at the Makah National Fish Hatchery has proven to be very reliable and effective in collecting brood for the hatchery. Adult fish freely enter the lift and are raised to a sorting flume without injury. A system with a redundant fish lift or pumps could be constructed for approximately 20 to 40 percent less cost than the ladder alternative.

4.3.4 MU-4, Fish Lift to Reservoir

Alternative MU-4 is shown conceptually on Drawing MU-4.1. This concept would transport fish directly from collection in the tailrace to the reservoir via an overhead tramway. Feasible alternatives for the overhead tram could range from a rigid track-guided crane or trolley system to an overhead cableway-type design such as modern ski lifts. Individual transport buckets could be designed to operate at frequencies ranging from minutes for the ski lift type system, to half-hourly, hourly or other cycles for a track system. Redundant buckets would be desirable.

The existing fish elevator entrance located in the downstream portion of the tailrace would be used. This concept could be adapted to either the existing fish elevator, or could transport sorted fish from a sorting facility, such as shown in Alternative MU-3. The same comments apply from the Phase 1 report regarding the entrance conditions (see Appendix A).

Phase 1 review comments confirmed that it is difficult to predict the optimal exit location for the fish tramway or lift without additional hydraulic or biological data. Fortunately, at this stage of development, a change in release location will not significantly affect the estimated cost of the facility. A release site located along the left bank of the dam, sufficient to reach the low reservoir water levels, is shown schematically on Drawing MU-4.1. Fish exiting at this location would be protected from spill, and could follow the south bank of the reservoir to their upstream destination. Additional design would be required to provide a well functioning fishway exit.

4.3.5 MU-5, Fish Lock to Reservoir

Alternative MU-5, a fish lock leading from a fishway entrance to the reservoir, was presented as a possible concept in the Phase 1 report. Further analysis indicates it would be a less efficient approach at the high head dam, and would be substantially more expensive than a fish lift constructed of fixed rails or overhead cableways.

For example, concrete wall thicknesses in the rectangular tower required for a fish lift to ascend 193 vertical feet would be on the order of 5 feet thick at the base of the tower. Cycle time for one load of fish would be about an hour per full cycle (crowd, close gate, lift, release, crowd out, close gates, drain, recycle crowd). While fish locks have some appeal due to the true water to water transfer and good water circulation, they are not cost nor operationally effective for high head dams when compared to a more conventional bucket type mechanical fish lift. This alternative will be dropped from further consideration, and no costs have been developed.

4.4 YALE DAM UPSTREAM ALTERNATIVES

The target species for upstream passage at Yale Dam include:

- Spring Chinook
- Coho Salmon
- Summer Steelhead
- Winter Steelhead
- Sea-Run Cutthroat
- Kokanee
- Bull Trout

The following species are not specifically considered for upstream passage at Yale Dam:

- Chum Salmon
- Pacific Lamprey
- Fall Chinook

4.4.1 YU-1, Yale Dam Fish Ladder

A conceptual fish ladder layout for Yale Dam is shown on Drawings YU-1.1 through YU-1.6. Design criteria are similar to the ladder, shown for Merwin Dam, leading to the

conceptual design of a Half Ice Harbor type ladder, with a flow of 24 cfs. As the ladder alternative is intended to illustrate a volitional system, no sorting or sampling facilities are shown on the conceptual designs. Costs for these facilities are included in Section 6.

4.4.1.1 Draft Tube Configuration

A tailrace analysis similar to that provided for the Merwin tailrace was conducted for Yale. Figure 4.4-1 provides a plan, front elevation, and section view through the draft tubes. The Yale turbines are 67 MW vertical Francis units, with a maximum flow of 4,880 cfs for both Units 1 and 2. The centerline of the runner is at elevation 236.0 feet msl, below the high design tailwater elevation of 240.0 feet msl. The turbines operate at 150 rpm. Table 4.4-1 provides a summary of calculated mean velocities throughout the tailrace of Units 1 and 2, taken at the 6 sections as shown in Figure 4.4-1.

Table 4.4-1. Calculated mean velocities at Yale tailrace, Units 1 & 2.

Gate Setting	Unit Flow (cfs)	Calculated Velocity at Sections Through Tailrace (fps)					
		V _{1 (face)}	V ₂	V ₃	V ₄	V ₅	V ₆
Max	4,880	13.0	21.8	25.4	24.9	34.1	43.1
¾ Gate	3,741	9.9	16.7	19.5	19.1	26.1	33.1
½ Gate	2,603	6.9	11.6	13.6	13.3	18.2	23.0
Min	1,464	3.9	6.5	7.6	7.5	10.2	13.0

Similar to the analysis at Merwin, velocities will not prevent fish from entering the tailrace. Because the Yale runner is located below the high design tailwater elevation of 240.0, fish could have access to the runners during non-operational periods or during start up. However, the velocities towards the turbine runner are higher than at the Merwin powerhouse, which would likely keep fish from contacting the runner blades at flows slightly less than half capacity.

No tailrace or draft tube barriers are proposed at this time, nor are cost estimates developed for the Yale powerhouse in this report.

4.4.1.2 Yale Fish Ladder Entrance

The ladder entrance alternative shown on Drawings YU-1.4 locates a new entrance pool downstream of the powerhouse. Powerhouse flow can range from zero to a maximum of 9,760 cfs with both turbines running at full capacity.

A well designed ladder entrance at the Yale site would require careful examination of the hydraulics near the powerhouse exit. Depending on turbine loading and which turbine is running, various circular hydraulic patterns have been noted. Hydraulic data would be helpful in laying out an entrance should the ladder alternative at Yale be carried forward.

The entrance pool shown on Drawing YU-1.4 shows 3 entrances capable of providing about 975 cfs of attraction flow. Attraction flow could be pumped from the tailrace. The entrance would also need to be designed to accommodate tailwater elevations fluctuating between 231.5 to 240 feet msl.

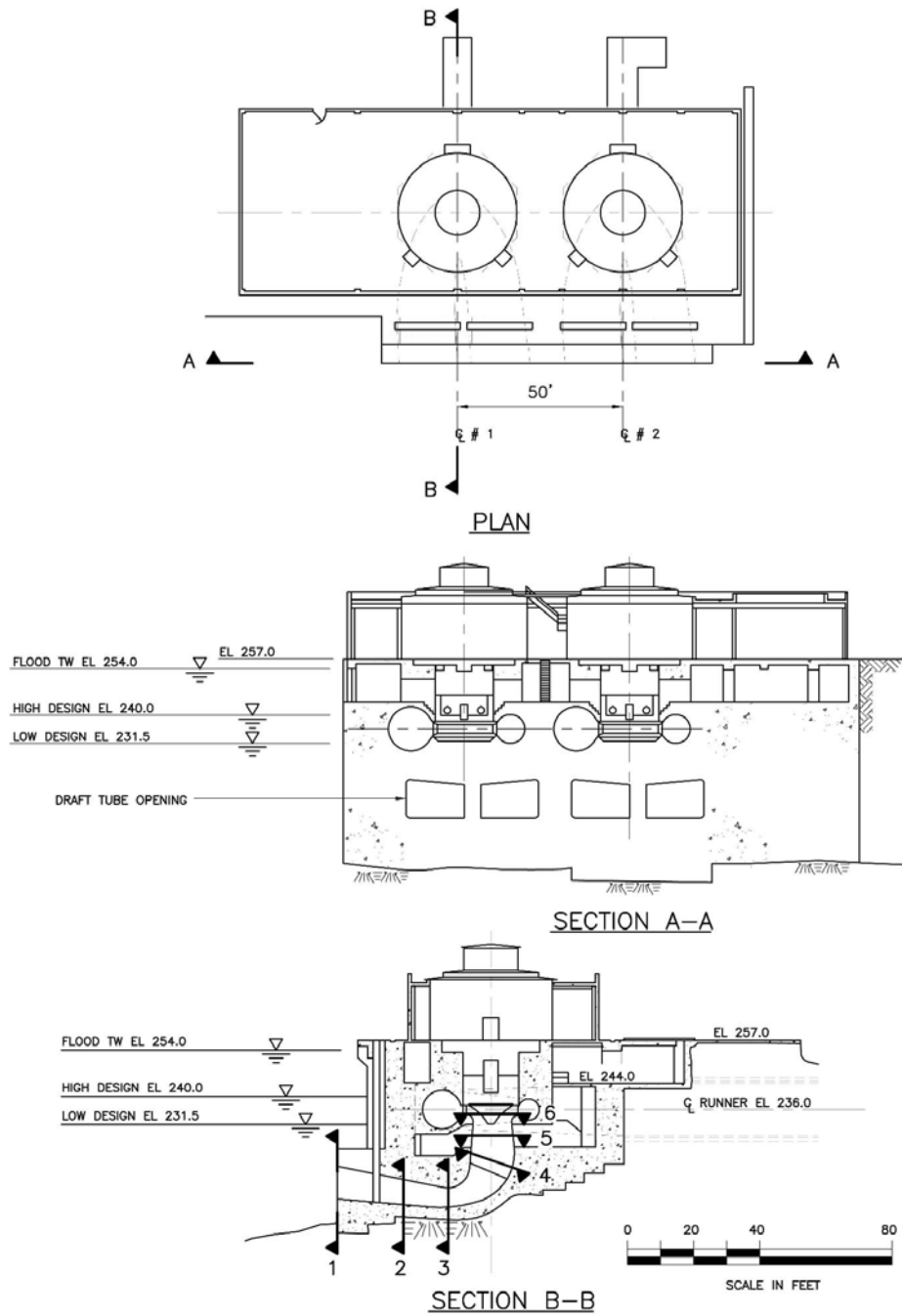

Figure 4.4-1. Yale Dam draft tube configuration.

4.4.1.3 Fish Ladder Design

Similar to Merwin, the overall elevation gain of the ladder is also a challenge at the Yale Dam site. A ladder at Yale would need to operate from the tailwater elevation of 231.5 feet msl to a reservoir full pool level of 490 feet msl. This is a total height of 258.5 feet.

The layout shown for the Yale fish ladder combines turning and resting pools similar to the Merwin ladder. These are sized at twice the regular pool volume and located every 12 vertical feet. Various sizes and locations are possible, but this assumption provides a reasonable starting point to explore feasible ladder alignments.

As shown on Drawing YU-1.1, the ladder alignment begins at a new entrance pool located on the downstream side of the powerhouse, and wraps back around the powerhouse toward the dam. The ladder would then traverse the lower portion of the earthfill dam, climbing towards the spillway. Special attention would be required to place the ladder on the engineered fill of the earth dam to ensure its integrity. The structure loading would need to be examined; however, it is expected that weight would not be the major concern. Ladder design to prevent any leakage following settling or an earthquake would be essential to locating a portion of the fish ladder on the dam section.

Following the traverse across the lower section of the dam, the ladder would bridge the spillway, with necessary protection from floodwaters and spray. The routing would then generally follow the spillway alignment towards an exit located along the north bank of the dam. Additional information on the exit is provided in Section 4.4.1.4.

Similar to the Merwin layout, an access road would be constructed along the entire length of the ladder. Fencing, grating, or other security measures would be required as discussed for the Merwin ladder. As shown on the ladder profile on Drawing MU-1.2 and on Section D of Drawing MU-1.3, the alignment up the spillway would require a cut of nearly 70 feet for about 500 feet of ladder length. The rock along the spillway area is known to be unstable, so additional geotechnical work would be required to refine the design. Should the ladder alternative be pursued, additional engineering development is recommended to optimize the ladder routing.

4.4.1.4 Fish Ladder Exit

A conceptual layout for a schematic Yale fish ladder exit structure is shown on Drawings YU-1.5 and YU-1.6. The exit structure would be designed to accommodate a more limited fluctuation in reservoir elevation than shown in the Phase 1 report: from a low of 474.0 feet to 490.0 feet msl, a fluctuation range of 16.0 feet.

A ladder exit located beyond the non-overflow dam section to the north of the spillway is shown on Drawings YU-1.1 and YU-1.5. Because the Yale Project rarely spills, adult fallback through the spillway would be a minimal concern at this exit location. Fish exiting the ladder could follow along the north shore of the reservoir, or could traverse across the spillway and face of the dam and migrate along the south shore. The exit structure shown illustrates a similar adjustable weir arrangement as shown for Merwin. The exit structure design and location would warrant further preliminary engineering later if this alternative is carried forward.

4.4.2 YU-2, Yale Trap and Haul

A trap-and-haul alternative for Yale Dam is illustrated on Drawing YU-2.1. This concept uses the same fishway entrance as the ladder alternative (see Section 4.3.1.2), accommodating the tailwater fluctuation elevation from 231.5 to 240 feet msl. Fish would then climb a volitional ladder to a handling facility similar to that described for Merwin. A short-term holding pond would be located at the terminus of the ladder, leading to a false weir, sorting flumes, and holding / transport tanks.

Although the site near the Yale powerhouse is constrained, the facilities sized for the Merwin alternative could be located immediately downstream of the powerhouse, as shown on Drawing YU-2.1. Construction of the fish ladder along the shoreline would require dewatering and in-water work, but the construction access and site grading offer no insurmountable challenges. Regrading the access road and construction of retaining walls would be necessary to accommodate the truck loading capabilities of this layout. A truck turn around may also be desirable downstream of the transport station, which is not shown on the drawings. A sampling and biological work-up building is also shown adjacent to the ladder. The size of this facility is shown conceptually, and no definitive goals are currently provided for design of a sampling building.

Water supply to the ladder and handling facilities could be pumped from the tailrace, with a gravity pipeline provided from the reservoir for back-up. Water temperatures consistent with the current river temperature would be important to supply the attraction pool and ladder.

Release sites such as boat ramps would be required at the upstream locations, as described for Merwin.

4.4.3 YU-3, Yale Fish Lift

Because of the similarity of the fish lift and fish lock designs at Yale to Merwin, no drawings are provided to describe Alternative YU-3. A fishway entrance would be required, leading fish to a tram or overhead cableway lift, similar to the concept shown on Drawing MU-4.1. An appropriate exit location would be required in the reservoir to accommodate water level fluctuations ranging from at least Elevation 474 to 490 feet msl. Costs are provided for a lift by considering scale and site constraints relative to the Merwin project.

4.4.4 YU-4, Yale Fish Lock

Fish locks were eliminated from further consideration at all sites due to the reasons stated for Merwin in Section 4.4.5.

4.5 SWIFT COMPLEX UPSTREAM PASSAGE ALTERNATIVES

This section identifies upstream passage alternatives at the Swift No. 1 and Swift No. 2 projects. Because operations of Swift No. 1 and Swift No. 2 are interrelated and hydraulically connected, facilities for both projects are examined together. The objective

of the Swift Complex upstream passage alternatives is to provide passage for the following target species.

- Spring Chinook
- Coho Salmon
- Summer Steelhead
- Winter Steelhead
- Sea-Run Cutthroat
- Bull Trout

The following species are not specifically considered for upstream passage at the Swift No. 1 and Swift No. 2 projects.

- Chum Salmon
- Kokanee
- Pacific Lamprey

4.5.1 SU-1, Swift Complex Fish Ladders

Fish ladder designs for the Swift No. 1 and Swift No. 2 projects are provided on Drawings SU-1.1 through SU-1.3. As noted in the Phase 1 report, passage at Swift No. 1 and Swift No. 2 is more complex than at Merwin and Yale dams. Concepts shown at this stage are preliminary, intended to promote discussion on overall goals for the 2 Swift projects, and to allow development of cost estimates.

A key decision will be to determine whether or not fish should be allowed into the Lewis River bypass reach between the Swift No. 1 spillway and the Swift No. 2 powerhouse tailrace. For planning purposes, schematic entrances are shown for passage beginning both at the Swift No. 2 tailrace and at the upstream end of the bypass reach (near the base of Swift Dam). Fish numbers and potential run sizes are similar to those examined for Merwin and Yale.

4.5.1.1 Swift No. 2 Draft Tube Configuration

A tailrace analysis was conducted for both Swift No. 1 and Swift No. 2 powerhouses. Figure 4.5-1 provides a plan, front elevation, and section through the draft tubes for the Swift No. 2 powerhouse.

The Swift No. 2 turbines are 35 MW vertical Francis units, with a maximum flow of 4,000 cfs for both Units 1 and 2. The centerline of the runner is at elevation 474.0 feet msl, which is equal to the low design tailwater elevation. The turbines operate at 128.6 rpm.

Table 4.5-1 provides a summary of calculated mean velocities throughout the tailrace of Units 1 and 2, taken at the 6 sections as shown in Figure 4.5-1.

Table 4.5-1. Calculated mean velocities at Swift No. 2 Tailrace, Units 1 & 2 .

Gate Setting	Unit Flow (cfs)	Calculated Velocity at Sections Through Tailrace (fps)					
		V _{1 (face)}	V ₂	V ₃	V ₄	V ₅	V ₆
Max	4,000	7.5	10.0	12.5	13.1	22.6	26.0
¾ Gate	3,000	5.6	7.5	9.3	9.8	17.0	19.5
½ Gate	2,000	3.8	5.0	6.3	6.5	11.3	13.0
Min	1,000	1.9	2.5	3.1	3.3	5.6	6.9

The draft tube velocities at Swift No. 2 are less than at both Merwin and Yale. At the higher flows, it appears the velocities are high enough near the runners to prevent fish from contacting the runner blades; however, fish may have access to this area at lower flows. Because the tailwater elevations are typically above the runner elevation, fish would have access to the runner blades at the lower operating flows. No tailrace or draft tube barriers are proposed at this time, nor are cost estimates developed for the Swift No. 2 powerhouse in this report.

4.5.1.2 Swift No. 1 Draft Tube Configuration

Figure 4.5-2 provides a plan, front elevation, and section view through the draft tubes for the Swift No. 1 powerhouse. The Swift No. 1 turbines are 80 MW vertical Francis units with a maximum flow of 3,040 cfs for each of the 3 units. The centerline of the runner is at elevation 607.0 feet msl. The turbines operate at 180 rpm.

Table 4.5-2 provides a summary of calculated mean velocities throughout the tailrace of Units 1 and 2, taken at the 6 sections as shown in Figure 4.5-2.

Table 4.5-2. Calculated mean velocities at Swift No. 1 tailrace, Units 1 through 3.

Gate Setting	Unit Flow (cfs)	Calculated Velocity at Sections Through Tailrace (fps)					
		V _{1 (face)}	V ₂	V ₃	V ₄	V ₅	V ₆
Max	3,040	7.0	10.2	12.7	12.3	19.7	22.9
¾ Gate	2,330	5.3	7.8	9.8	9.4	15.1	17.5
½ Gate	1,621	3.7	5.5	6.8	6.5	10.5	12.2
Min	912	2.0	3.1	3.8	3.7	5.9	6.9

Note: velocities are estimated based on estimated draft tube cross sectional areas.

The draft tube velocities at Swift No. 1 are the lowest of all the projects. As was described for Swift No. 2, it appears the velocities are high enough near the runners to prevent fish injury. However, fish may have access to this area at lower flows. No tailrace or draft tube barriers are proposed at this time, nor are cost estimates developed for the Swift No. 2 powerhouse in this report.

4.5.1.3 Swift No. 2 Fish Ladder Entrance

Tailwater elevations at the Swift No. 2 powerhouse will vary from elevation 470.0 feet msl to the Yale full pool elevation of elevation 490.0 feet msl. This entrance would therefore need to be designed to accommodate a 20 foot fluctuation. Maximum discharge from the Swift No. 2 powerhouse is 8,000 cfs. Attraction flows of 5 percent and 10 percent of the total powerhouse capacity would equal 400 and 800 cfs, respectively.

Drawing SU-1.1 illustrates a Swift No. 2 ladder entrance on the upstream side of the powerhouse. As the specific design of an entrance will depend on Swift bypass reach decisions, additional detail is not provided at this time. For example, if the decision is made to exclude fish from the bypass reach but to collect them near the Swift No. 2 tailrace, a fish barrier (dam, velocity barrier, etc.) would be desirable upstream of the Swift No. 2 ladder entrance. The entrance location shown on Drawing SU-1.1 is intended to communicate location only. Additional site specific entrance details can be developed in the future if this concept is carried forward.

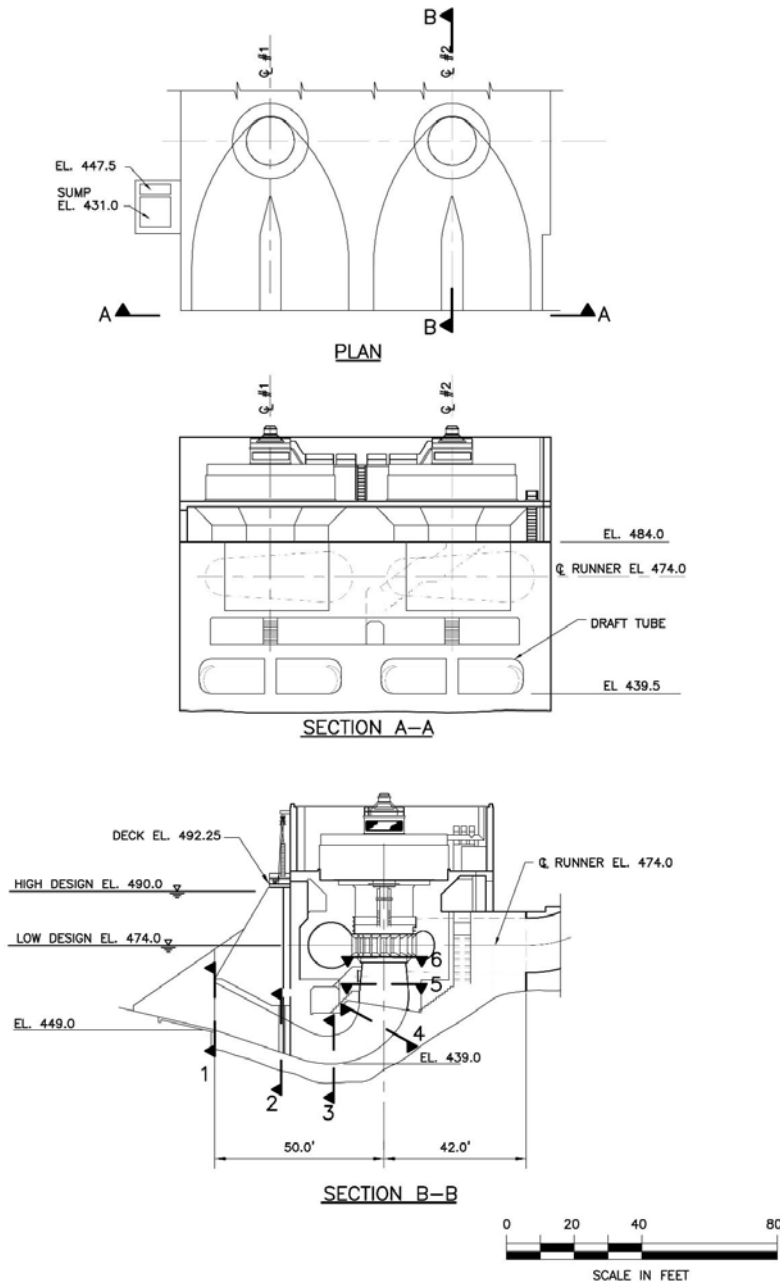

Figure 4.5-1. Swift No. 2 draft tube configuration.

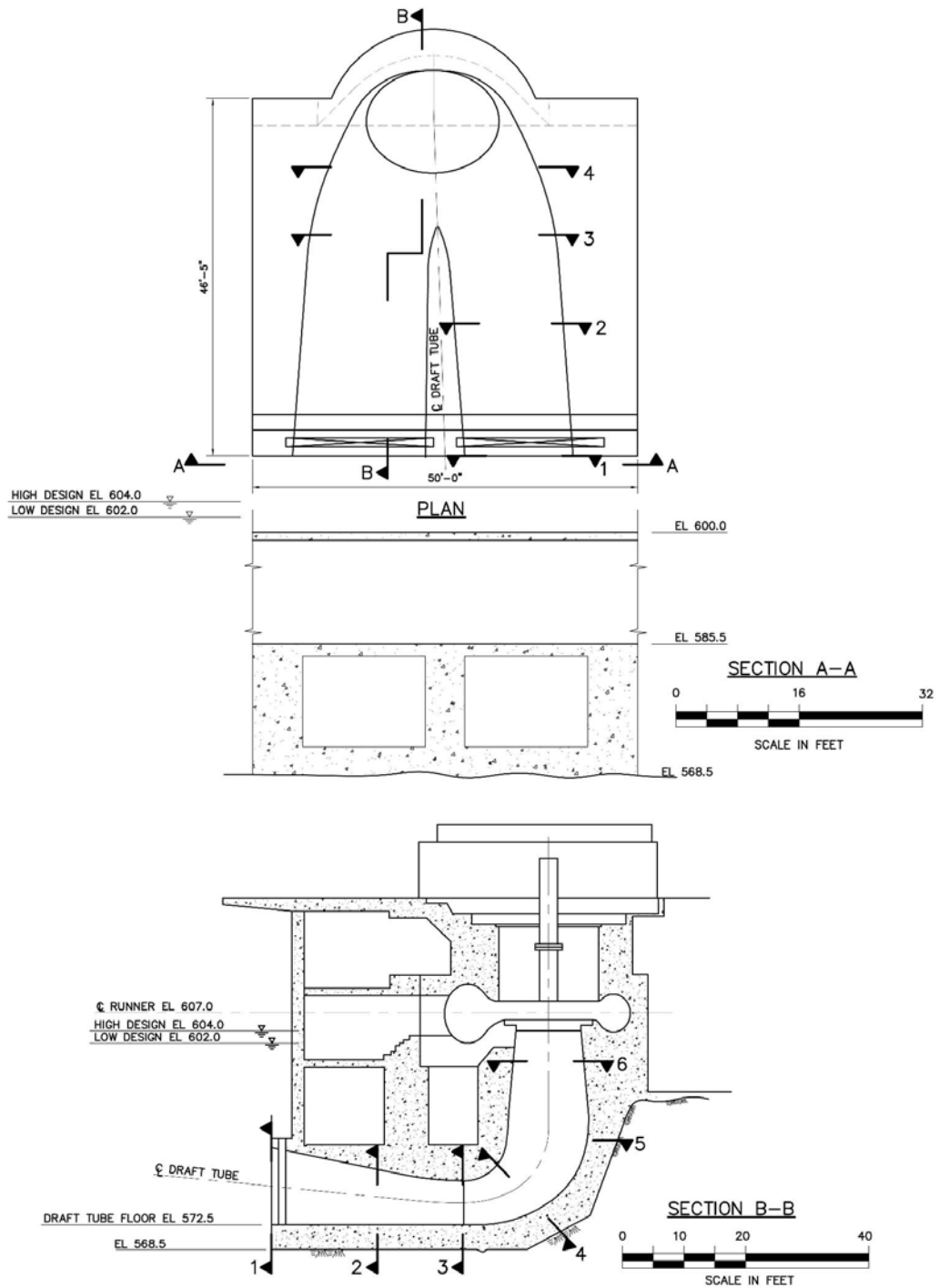

Figure 4.5-2. Swift No. 1 draft tube configuration.

4.5.1.4 Swift No. 1 Fish Ladder Entrance

The hydraulic capacity of the Swift No. 1 powerhouse is 9,120 cfs, and is slightly greater than the Swift No. 2 powerhouse. These projects run in tandem: flows released from the Swift No. 1 powerhouse into the canal pass directly through Swift No. 2 powerhouse. During the infrequent periods when Swift No. 1 discharge exceeds Swift No. 2 capacity, excess flow is spilled through the wasteway back to the Swift bypass reach, shown on Drawing SU-1.2.

As described in the Phase 1 report, a ladder entrance dedicated to the Swift No. 1 powerhouse would likely lead from the bypass reach. Specific design flows and tailwater fluctuation at a ladder entrance are not known at this time, as the projects are not currently operated to release water to the bypass reach. For planning purposes, the entrance location shown on Drawing SU-1.2 is a reasonable starting point. This entrance would be at approximately elevation 600 feet msl.

4.5.1.5 Swift Fish Ladder Designs

To examine feasible alternatives and to identify design concerns, 2 entrances are shown for fish ladders at the Swift Complex: one near the Swift No. 2 powerhouse and one near the Swift No. 1 powerhouse. A ladder from the Swift No. 2 powerhouse would need to operate from the low tailwater elevation of 470 feet msl to a Swift Reservoir full pool level of 1,000 feet msl, a total height of 530 feet. This elevation assumes that fish collected near Swift No. 2 would be transported directly to the reservoir, as there would be little to no value in allowing fish collected at the Swift No. 2 tailrace to exit into the canal. As stated in the Phase 1 report, this is an extremely high fish ladder without supporting data that it would be effective.

Assuming no fish would be purposely introduced into the Swift No. 2 canal, a ladder entrance at Swift No. 1 could be located at the upstream end of the Swift bypass reach if basin management goals desired flow in that reach. This ladder would need to climb from an approximate bypass channel elevation of 600 feet msl to the full pool elevation of 1,000 feet msl, a gain of 400 feet. Again, a 400-foot-high fish ladder is very high, and it is not known if it would be effective.

A Half Ice Harbor ladder design as discussed for Merwin and Yale would also be applicable to the Swift projects, complete with resting and turning pools as described for Merwin. Given the nearly 3-mile distance from the Swift No. 2 powerhouse to Swift Reservoir, it is not necessary for the ladder to climb the entire route. A combination of ladder and open flow channel sections is possible for the ladder starting at the Swift No. 2 powerhouse.

As shown on Drawing SU-1.1, the ladder alignment from the Swift No. 2 powerhouse would begin at the upstream side of the powerhouse, then ascend the embankment in a Half Ice-Harbor ladder section. This section crosses under the highway and continues up towards the canal, away from the river floodplain. Following an initial elevation gain of 130 feet, the concrete fish ladder would transition into an open channel, which could run parallel to the canal. The intent with this routing is to keep the fish channel as far as possible from the floodplain, and to avoid the steep banks and benching into the hills on

the north side of the canal. The alignment generally follows the canal south bank in a series of alternating channel and concrete ladder sections until it crosses the canal. Here it would transition permanently into a concrete section to climb the grade over Swift Dam. Typical sections illustrating ladder features are provided on Drawing SU-1.3.

A preliminary alignment for a Swift No. 1 ladder is also shown on Drawing SU-1.2. After beginning in the bypass reach, a feasible alignment for this ladder would traverse the base of Swift Dam, and then switchback up the hillside until it connects to the alignment shown for the Swift No. 2 ladder. The common ladder would then climb along the steep hillside towards the north side of Swift Reservoir, requiring a cut section of over 200 feet to reach the reservoir. Tunneling would likely be more economical than the open cut section shown, but drawings SU-1.2 and SU-1.3 help to illustrate the confined site available at Swift to construct a ladder.

Given the long route for the ladder, an access road would be constructed along its entire length. Security fencing, grating, or other exclusionary measures would be required to discourage poaching and vandalism. Other issues such as geotechnical information and design goals, as discussed for Merwin and Yale, are relevant at Swift. It is important to note that the alignments shown at this time are to communicate design challenges and site features. Additional engineering development would be required to optimize the ladder design.

4.5.1.6 Swift Fish Ladder Exit

A location for a common Swift ladder exit structure is shown schematically on Drawing SU-1.2. Assuming the north bank ladder routing is preferable to a south routing, the ladder could exit along the north shore of the reservoir in deep enough water to operate at low reservoir elevations. The Swift Project has the most storage of the 3 Lewis River reservoirs, and has operational goals that include power generation and flood management. As such, Swift Reservoir fluctuates seasonally more than the other reservoirs. Forebay fluctuation design values proposed in Section 2.2.5 range from elevation 960.0 to the full pool elevation of 1,000 feet msl, a fluctuation of 40 feet (reduced from elevation 942.0 in the Phase 1 report).

The limiting cases for exit structure design to handle such a large fluctuation would either require that fish ascend a ladder to nearly the top of the dam and return to the reservoir through a slide type system; or a deeper penetration would be required through the dam (larger than shown for Yale or Merwin) to allow fish to swim directly from a multiple weir outlet structure to the reservoir. Drawings SU-1.3 through SU-1.4 illustrate a possible ladder exit facility that could accommodate this range of fluctuation.

4.5.2 SU-2, Swift Complex Trap-and-Haul

A trap-and-haul facility similar to those shown for Merwin and Yale would be applicable at the Swift Projects. Due to the similarity of concepts for the Merwin and Yale trap-and-haul designs along with the need for additional basin goal guidance on the bypass reach, no drawings specific to the Swift Projects are included in this document. Costs provided in Section 6 have been proportioned to the Merwin and Yale facilities.

4.5.3 SU-3, Swift Fish Lift to Reservoir

A dedicated fish lift to Swift Reservoir would be a reasonable alternative for either the Swift No. 2 or Swift No. 1 fishway entrance locations described in Section 4.5.1.3. Additional detail and a discussion of fish lifts is provided for both Merwin and Yale dams, with the only pertinent difference being the additional cycle time necessary to ascend the higher head at Swift No. 1. Costs provided in Section 6 are proportioned to these facilities.

4.5.4 SU-4, Swift Fish Lock

The 400 to 600 feet of head necessary to reach Swift Reservoir eliminates the viability of a fish lock as a reasonable alternative, as described for the Merwin project.

5.0 DOWNSTREAM PASSAGE FACILITIES

5.1 PHASE 2 DOWNSTREAM FACILITY INFORMATION

Downstream passage facilities designed to meet the 7 system plans identified in Section 3 are described in this section, which is organized similarly to Section 4. Some of the downstream facilities presented in this section were conceptually described in the Phase 1 report. Information added to supplement the Phase 1 report includes (1) adjustments to the designs to incorporate comments received and discussed by the ARG; (2) modifications to designs to accommodate more refined reservoir fluctuation criteria described in Section 2; and (3) new downstream alternatives. Designs have been advanced sufficiently to develop cost estimates. Facility descriptions supercede the Phase 1 report information.

Facilities illustrated by conceptual drawings are located under Tab B, with naming conventions shown on Figure 5.1-1. Concepts developed for one project are referenced in later drawings where duplication of ideas occurs. Concepts that could be applied equally at each dam are generally illustrated once to avoid duplication. This is especially true with the Swift No. 1 downstream passage facilities. Individual design features illustrated for Swift are referenced for adaptation at other sites. While this won't provide a true representation, it will be adequate at this phase for decision making and cost estimating.

5.2 REFERENCE TO COST INFORMATION

The conceptual designs have been developed to prepare a meaningful estimate of expected performance and a construction cost for each facility. It is expected that some level of design optimization based on ARG and other input, future fish behavior data, and other information would be required prior to implementing any of the conceptual designs.

A summary of the cost information is provided in Section 6. Each major component of the downstream fish passage facilities is referenced to a cost value in Section 6. The order of presentation of the various facility components has been revised from the Phase 1 report to correlate facilities with the cost summary table.

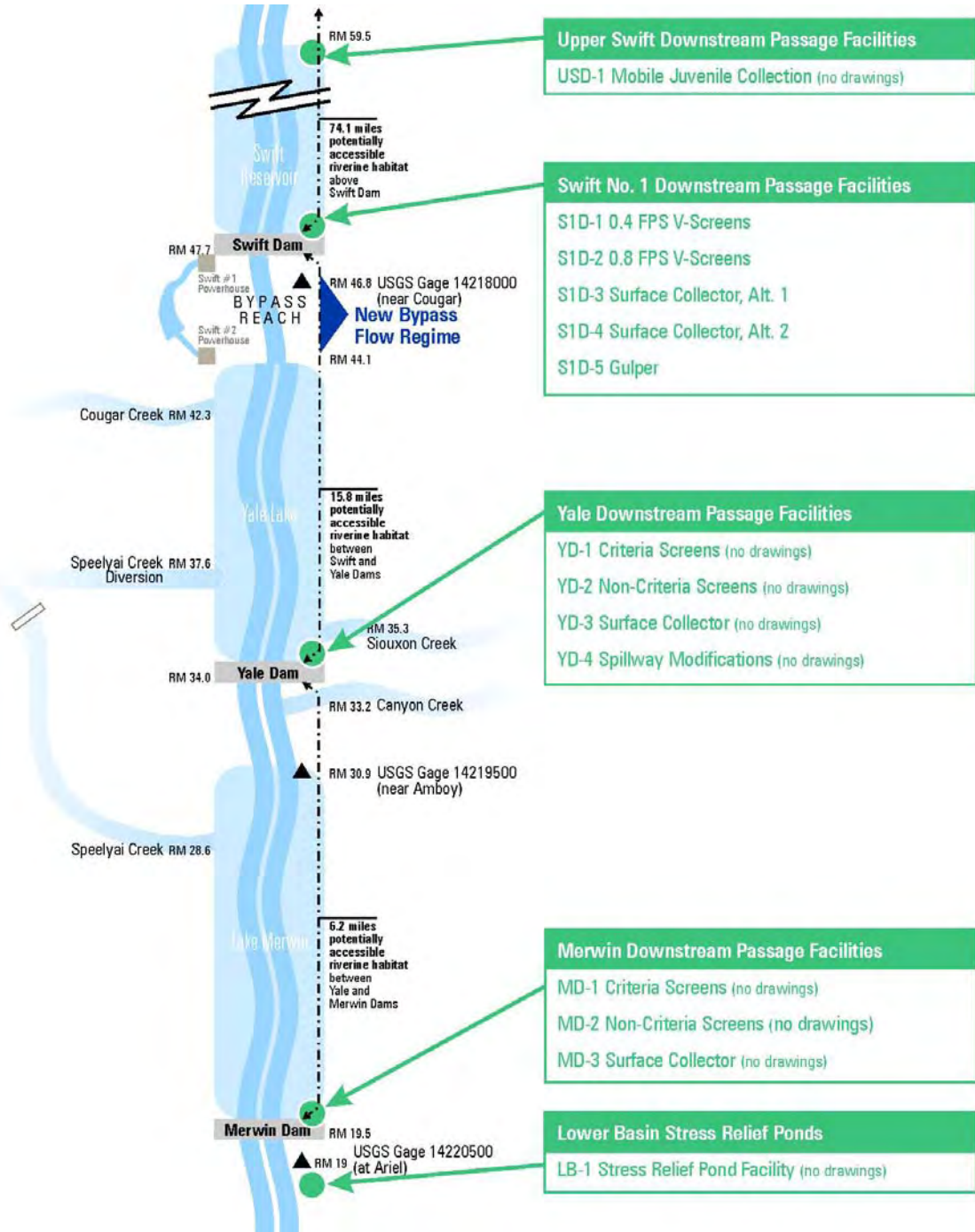

Figure 5.1-1. Key to downstream passage facilities.

This page intentionally blank.

5.3 UPPER SWIFT RESERVOIR

The Phase 1 report provided a description of potential downstream collection facilities that could be located in the upstream end of Swift Reservoir. The intent with this type design was to capture fish before they enter the reservoir, and transport the fish via truck to a downstream release location. This led to the design of another major dam immediately upstream end of the reservoir to collect and sort fish through this collector.

The ARG commented that it was not desirable to construct such a large structure that would effectively be a barrier for upstream migration. There was ARG consensus to eliminate this upstream collector from further consideration.

5.3.1 USD-1 Mobile Juvenile Collectors

Mobile juvenile collectors have been considered by the ARG to aid in collecting fish at the upstream end of Swift Reservoir. These collectors are envisioned to be passive Merwin traps or screw traps anchored to the shore. Both of these approaches would be labor intensive to operate and would require some handling of fish.

The development of mobile juvenile collectors in the upper reaches of Swift Reservoir is feasible.

5.4 SWIFT DAM DOWNSTREAM PASSAGE FACILITIES

Exclusionary screens designed to screen all or a specified percentage of the flow could be used at Swift Dam to collect outmigrating juveniles. Exclusionary screens are defined as facilities that physically screen fish from the intake flow. Fish would be directed with physical screen panels away from turbine intakes toward bypass facilities, where they either would pass downstream to the next reservoir or river, or be routed to a handling and transport facility to be trucked around other dams.

Examination of full exclusionary screens represents the upper bounds of screening technology. Partial screens and high velocity screens are variations on the exclusionary screening concept that have proven successful at some other locations. Due to the scale and nature of facilities necessary to collect fish at Swift Dam, WDFW's comment letter (Appendix A) indicated a willingness to explore alternate screen criteria. For example, it was suggested that the standard approach velocity criteria of 4 fps and a maximum exposure to the screen of 60 seconds before reaching a bypass, could be doubled, (Appendix A). This would result in screen criteria of 0.8 fps, and travel time to a bypass outlet of 2 minutes.

The other bounding case for downstream collection is a surface collector concept. This depends more on behavioral characteristics where fish are attracted to a surface flow and passed without screening. Surface collectors can be gravity fed, created through existing spillways, or created on floating barges run by either gravity or pumps which create a flow field attractive to fish. The floating barge concept is known as the gulper concept (often called the Baker Gulper based on a successful concept at Baker Lake in Washington,

owned and operated by Puget Sound Energy). A gulper would represent the other bounding case for downstream passage alternatives for the Lewis River Projects.

Other concepts such as tributary collectors represent a commonality with the upstream collector or the above options, which could be designed at appropriate scales for the flow. Additionally, behavioral devices such as strobe lights, sound generators, scented water, water temperature regulation, electric fields, bubble curtains, etc. have been used or are currently being researched to varying degrees of success. These concepts are not commonly accepted by agencies as primary passage devices.

This report examines 5 unique approaches to collecting fish at Swift Dam. Although site specific geometry and siting are critical to the design of similar facilities at the other Lewis River dams, issues important for consideration at Swift are common to each site. The designs shown in the following sections, along with variations such as high velocity screens, other surface collection concepts, etc., will be sufficient to communicate design needs for each site, and allow discussion of potential operational efficiency.

5.4.1 S1D-1 0.4 FPS V-Screens

A conceptual design to screen the entire Swift No. 1 intake flow to achieve current agency criteria is shown on Drawings S1D-1.1 and S1D-1.2. As mentioned previously full exclusionary screens represent the upper bounds of screening for this facility. Screens shown upstream of the existing intake in Alternative S1D-1 are sized to accommodate 9,120 cfs, the full hydraulic capacity of the Swift No. 1 powerhouse. Banks of 4 sets of V-screens, with 150-foot long screen panels 20 feet high would be required to meet the 0.4 fps approach velocity criteria. The 150-foot length would also allow entrance to a single bypass within 60 seconds, assuming fish act as a neutrally buoyant particle. As shown in the drawings, an overall structure length of approximately 450 feet with a width of at least 250 feet would be required to accommodate the screens.

Similar to the Alternative USD-1, each screen would bypass approximately 50 cfs, leading to a secondary dewatering facility that would further screen the fish bypass flow to about 30 cfs. Flow initially screened from the intake would be routed to the turbine intakes. Flow from the secondary dewatering facility could be routed to the sorting and holding/handling facility below the dam on the opposite bank. From there, the flow would encounter more screens that would reduce the flow to approximately 2 cfs. The screened flow could then be routed to the spillway, or a low head pump could be provided that would direct this excess flow to the surge tank to allow continued generation of power.

The screen facility would have to accommodate a reservoir fluctuation of 40 feet, to the low water design elevation of 960.0 feet msl. The bottom of the screen panels would be set at or below elevation 940 feet msl as shown on Drawing S1D-1.2.

The configuration shown provides for secondary dewatering immediately downstream of the primary screens. The dewatering facility would reduce flows in the bypass pipe to approximately 30 cfs, and would allow screened flow to be reintroduced to the power tunnel. These flows may be created with a venturi effect using the existing turbine

bulkhead, or may require a low-head pump to generate this flow. The configuration shown allows continued operation of the existing spillway gate, and allows for construction while the plant remains in operation.

There are several design challenges with this arrangement. Construction of the screen foundation would require either a drawdown for construction of the facility in the dry, or would require a large cofferdam. The site is very steep along the left bank, so a large retaining wall may be necessary to prevent slides over the facility. Design and installation of the penstock to deliver dewatered flows from the v-screen to the turbine inlet would be a particular challenge. Lastly, penetration of the dam for the 30-inch diameter HDPE bypass pipe would require special tunneling and extreme care to maintain the structural integrity of Swift No. 1 Dam.

The sorting/handling facility shown on S1D-1.2 and S1D-1.3 includes dewatering, sub-sampling in an interior lab, sorting, and routing to a holding facility. The layout of this facility is modeled after the juvenile collection facility designed for the Cowlitz Falls Project. The facility would contain additional dewatering flumes, fish separators and facilities to handle any adult fish that may enter the system, sampling facilities and biological work space, juvenile holding ponds, and a truck loading facility. Waste water treatment and a truck disinfection station also would likely be required. The footprint shown on Drawing SID-1.3 is the minimum required as this facility was designed for a very constrained site at Cowlitz Falls. Due to the elevations required to maintain flow throughout the overall system, there would be large quantities of rock excavation necessary to site the building.

5.4.2 S1D-2 0.8 fps V-Screens

Drawings S1D-2.1 and S1D-2.2 provide a conventional approach to a higher velocity vee screen structure, to examine how relaxing the 0.4 fps approach criteria would impact the screen feasibility as suggested by WDFW (Appendix A). This screen would be the same concept, but almost half the size of the bank of screens shown for S1D-1.2. Elevations and major components would be the same for both high and low velocity. Costs are provided for a 0.8 fps V-screen in Section 6 to illustrate the potential savings resulting from a relaxation of the downstream passage criteria.

5.4.3 S1D-3 Surface Collector Alt 1, Gate in Spillway

Due to the complexity and high costs of the more conventional V-screens, surface collector concepts sited to utilize the existing structures were examined. The concept shown on Drawing S1D-3.1 was developed to utilize the existing spillway channel structure to draw fish and flow from the existing deep intake. This alternative would take advantage of fish behavior to attract the more surface oriented species with a partial attraction flow.

For this alternative, a new miter gate would be located immediately downstream of the 50-foot-high radial spillway gate. Spillway channel walls would be raised to the new miter gate to contain flows in the channel at full pool. In this configuration, the miter gate would close off the spillway channel, and the existing radial gate would be lifted to

its full up position. Flows passing under the radial gate would be diverted into a new fish channel, leading towards a V-screen sized to dewater at least 600 cfs. Six hundred cfs was selected as 10% of the maximum flow of 6,200 cfs during the outmigration period (Table 2.3-1, rounded to 600 cfs). The existing spillway radial gate crest is constructed at elevation 950.0 msl. Allowing the channel-based surface collector to operate down to elevation 960 would still allow for a 10-foot depth of flow at low design pool. A 20-foot-wide by 10-foot-deep channel would result in velocities of 3 fps with the 600 cfs flow.

After fish pass through the V-screen, they would be subjected to a ramped head dissipation and dewatering area to help adjust flows during various flow and reservoir conditions. This structure would be a challenge to design in the footprint shown in order to accommodate a full 40-foot fluctuation in pool elevation. Fish passing through the ramp section would enter the sorting and holding facilities similar to those shown for Alternative S1D-1.1. Dewatered flow from the V-screen would be pumped to the surge tank with a low head pump to allow generation with over 400 feet of head. An emergency spillway would be necessary as a backup system to the low-head pump.

One of the advantages of this design is it maintains full use of the south spillway at all times. Additionally, the miter gate could be closed relatively quickly, so the capacity of the north spillway would not be reduced.

Drawing S1D-3.1 also shows an alternate surface attraction gate configuration located upstream of the existing north radial gate. This entrance would require construction of a new guide wall on the upstream edge of the spillway. In this scenario, a dedicated gate would be provided for the fish facilities that would be completely independent of the spillway system.

5.4.4 S1D-4 Surface Collector Alt 2, Floating Surface Collector

Alternative S1D-4 was developed in an effort to reduce costs from the conventional V-screen designs. This concept uses a floating gulper-type barge (see Drawing SID-4.1) with an inclined screen that actively generates attraction flow through a pipe penetrating the dam. Similar to the design flow discussed in Section 5.4.3, the floating surface collector shown is sized for at least 600 cfs. This approach to the surface skimmer or gulper concept would not induce currents in the reservoir near the intake, as would a conventional gulper with pumps which may reduce turbulence and allow fish to more easily find a passageway out of the reservoir.

A guide wall would be provided to create a channel upstream of the intake, which would help direct all fish towards the intake.

Water used for attraction flow is extremely valuable at this site due to the 400 feet of available head. A low head pump station would recover the attraction flow for generation by pumping the attraction water back into the penstock.

A sorting facility similar to that shown in Drawing S1D-1 would be provided near the surge tank. Other conceptual design details are provided in the drawings SID-4.1 and SID-4.2.

5.4.5 S1D-5 Gulper

Based on comments received at the ARG meetings, the gulper concept was carried forward from the Phase 1 report. Drawings S1D-5.1 and S1D-5.2 illustrate a larger gulper to match the 600 cfs capacity of Alternative S1D-4. This concept would generate the same attraction flow as Alternative SID-4, however, instead of just pulling the water through the intake screen, this approach would result in flows being introduced in the forebay and attraction channel by the pump discharge. This discharge flow from the gulper may reduce its effectiveness for attracting fish by confusing natural flow patterns upstream of the intake. Although not shown, both the guide wall and lead net concepts are optional items that could enhance the performance of this alternative.

5.5 SWIFT NO. 2 POWERHOUSE

Downstream passage facilities are not anticipated to be constructed at the Swift No. 2 powerhouse.

5.6 YALE DAM DOWNSTREAM PASSAGE FACILITIES

5.6.1 Downstream Passage Alternatives

All of the conceptual alternatives examined at Swift No. 1 would be applicable at the Yale Dam. Costs are proportioned by flow for facilities similar to Swift No. 1 and are presented in Section 6.5.6.2 Spillway Modifications

In addition to the screen or surface collector facilities that could be added to the Yale Project, PacifiCorp has planned for spillway improvements to increase the fish survival during low spill events (6,000 cfs or less).

The existing spillway has a rock outcrop at its downstream end as shown on Drawing YU-1.1. Figure 5.6-1 provides a rendering of modifications proposed by PacifiCorp.

The modifications would create a channel through the hazardous rock area allowing safe fish passage. The channel would be 25-foot-wide with a 5-foot minimum depth. It would smoothly transition from the existing lined spillway and continue down to the water edge.

5.7 MERWIN DAM DOWNSTREAM PASSAGE FACILITIES

5.7.1 Downstream Passage Alternatives

All of the conceptual alternatives examined at Swift No. 1 could also be applied to Merwin Dam. Costs are proportioned by flow for facilities similar to Swift No. 1 and are presented in Section 6.

This page intentionally blank.

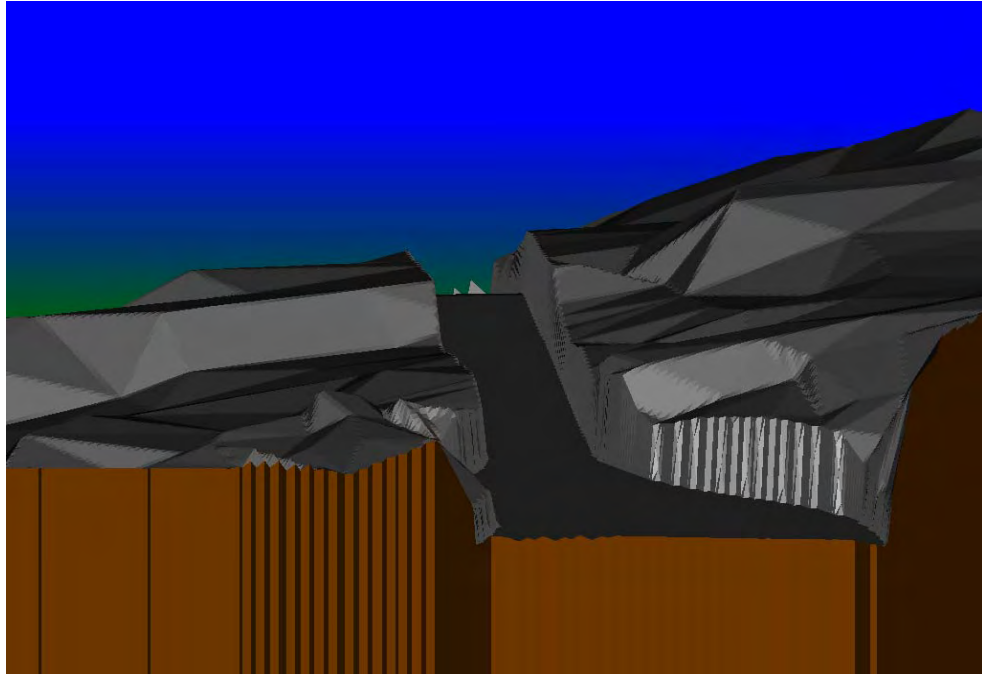

Yale Spillway Looking Downstream
At Rock Outcrop (Proposed Channel)

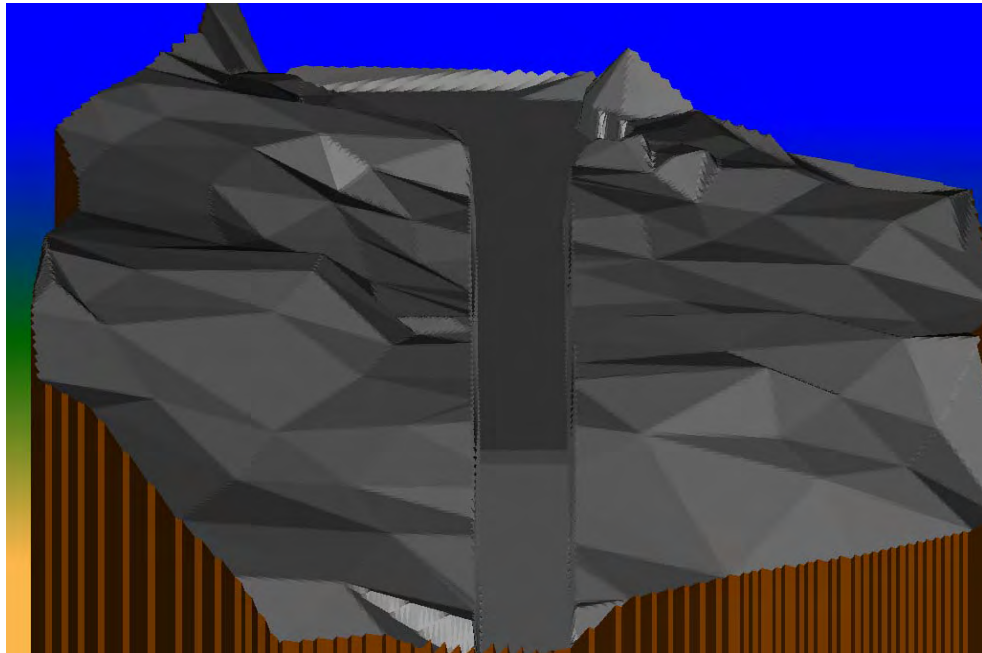

Looking Upstream From Below
Rock Outcrop (Proposed Channel)

Figure 5.6-1. Yale Project Spillway Extension Project

(Source: PacifiCorp, 2002)

This page intentionally blank.

5.8 LOWER BASIN

5.8.1 LB-1, Stress Relief Pond Facility

One final component in a downstream passage facility plan may be to provide stress relief ponds near the final juvenile release site. Stress relief ponds are thought to reduce fish stress following truck transport. It should be noted that not all biologists agree that stress relief ponds are necessary, and many downstream passage systems release fish directly to the river following transport.

Facilities funded and constructed by BPA at the Cowlitz Salmon Hatchery in 1995 in support of the Cowlitz Falls Upper Basin restoration project included stress relief ponds. The ponds were sized to hold fish for 24 hours during the peak, overlapping outmigration fish run. Twelve ponds were configured in a bank of 8-foot-wide by 50-foot-long by 5-foot-deep concrete raceways, designed with outlet structures that allowed volitional exit to the river. Fish that chose not to exit within 24 hours could be forced out of the raceway via crowders or by draining a single pond. This subjects the fish to stress which is the reason for mixed opinions of this type of facility.

As concrete raceways are a standard fish culture feature and fish numbers for outmigrants are not yet available for planning purposes, no drawings were developed specifically for stress relief ponds. A site at or near the Merwin Hatchery would be a reasonable assumption for siting stress relief facilities. Additional discussion on whether or not these ponds are a desirable feature for the Lewis River is warranted in future ARG meetings, prior to developing site specific conceptual designs.

6.0 PLANNING LEVEL COST ESTIMATES

Planning level cost estimates are provided to allow comparison of the various facilities and systems.

6.1 FACILITY COSTS

Cost estimates were prepared for individual passage facilities, tailored where possible for specific fish passage systems. The cost information is intended to be conservative, based on quantity take-offs from the conceptual drawings, a comparison of past projects of similar scope, and the 2001 Means estimating manual (Means 2001). A 30 percent contingency was added to the construction subtotal to cover unforeseen items, and to address issues not yet analyzed in detail. An additional 25 percent fee was added to the construction subtotal cover engineering, permitting, construction management and administrative costs. Costs are represented in 2001 dollars.

Detailed spreadsheets showing the estimated cost breakdowns for fish passage facilities are provided in Tab C, Appendix B. The estimated accuracy for the estimates is approximately -25 percent to +50 percent. In other words, actual system costs could be up to 25 percent less or 50 percent more than costs shown for each facility.

6.2 SYSTEM COST DEVELOPMENT

Individual fish passage facility costs are important as components to an overall system analysis. Table 6.2-1 provides a comprehensive summary of total system costs, with individual facility costs provided in a “building block” format along the left column. This presentation allows the reader to critique individual systems for key cost items, and allows facilities to be mixed and matched to customize other potential passage systems.

Components contributing to the complete system costs are provided alongside the component cost description, and the total system cost is totaled in the bottom row. Costs associated with upstream passage systems, depicted on table 6.2-1 are consistent between subsystem options. Because multiple downstream collection facility options have been developed, the seven systems are subdivided into further categories and presented in their own columns. Downstream collection facilities include two types of screens and three types of surface collectors. For example, System 1 is divided into Subsystem A and B. Subsystem A includes costs for the 0.4 fps criteria screen and Subsystem B includes cost for the 0.8 fps non-criteria screen. System 2 is divided into Subsystem A, B, and C. Subsystem A includes costs for the modified spillway surface collector, Subsystem B includes costs for the skimmer surface collector and Subsystem C includes costs for the Gulper surface collector.

Given the order of magnitude of many of the component costs, estimates were made for repetitive facilities based on detailed work from other facilities.

6.3 SYSTEM COST SUMMARY

Table 6.3-1 provides a summary total of system costs.

Table 6.3-1. System Cost Summary

	\$ in Millions
System 1 Volitional with Screens	
A Criteria Screens	381.0
B Non-Criteria Screens	345.3
System 2 Volitional with Surface Collector	
A Modified Spillway Surface Collector	279.5
B Skimmer Surface Collector	281.0
C Gulper Surface Collector	280.2
System 3 Fish Lifts u/s, Surface Collectors d/s	
A Modified Spillway Surface Collector	223.3
B Skimmer Surface Collector	224.8
C Gulper Surface Collector	224.0
System 4 Fish Lifts u/s, Surface Collectors d/s with Trucking Facilities	
A Modified Spillway Surface Collector	250.5
B Skimmer Surface Collector	252.0
C Gulper Surface Collector	251.2
System 5 Trap and Haul to Upper Swift with Surface Collectors, (bypass Merwin and Yale)	
A Modified Spillway Surface Collector	62.3
B Skimmer Surface Collector	63.7
C Gulper Surface Collector	62.9
System 6 Trap and Haul to Upper Swift with Screens, (bypass Merwin and Yale)	
A Criteria Screens	91.3
B Non-Criteria Screens	80.9
System 7 Resident Trap and Haul (no anadromous reintroduction)	
A Criteria Screens	274.4
B Non-Criteria Screens	238.7

Table 6.2-1 System Cost Detail

Lewis River Fish Passage Study Potential Fish Passage System's and Associated Costs (\$ in Millions)

System Description	Component Cost	Anadromous Reintroduction Volitional with Criteria Screens Up: Full Ladders at Each Dam Down: Full Screens w/ Subsampling Facilities		Anadromous Reintroduction Volitional with Surface Collector Up: Full Ladders at Each Dam Down: Surface Collector w/ Subsampling Facilities		Anadromous Reintroduction Fish Lifts u/s, Surface Collectors d/s Up: Fish Lift to Next Reservoir Down: Surface Collector w/ Subsampling Facilities			Anadromous Reintroduction Fish Lifts u/s, Surface Collectors d/s with Trucking Facilities Up: Fish Lift to Next Reservoir including truck loading, some hatchery Down: Surface Collector w/ Subsampling Facilities And / Or Holding and Trucking Facilities			Anadromous Reintroduction Trap and Haul to upper Swift with Surface Collectors, (bypass Merwin and Yale) Up: Trap w/ Holding/Sorting/Trucking Fac. at Merwin Down: Surface Collector at Swift w/ Holding / Trucking Fac.			Anadromous Reintroduction Trap and Haul to upper Swift with Screens, (bypass Merwin and Yale) Up: Trap w/ Holding/Sorting / Trucking Fac. at Merwin Down: Screens at Swift #1 w/ Holding/Trucking Fac.		Non-Anadromous Resident Trap and Haul (no anadromous reintroduction) Up: Trap w/ Holding/Sorting/Trucking Fac. at Merwin, Yale and Swift Down: Screens at Swift #1, Yale and Merwin		
		System 1		System 2		System 3			System 4			System 5			System 6		System 7		
		A	B	A	B	C	A	B	C	A	B	C	A	B	C	A	B	A	B
System No.																			
Upstream Passage Facilities																			
Merwin Dam																			
Fishway Entrance, Exist Configuration (24-100 cfs)	\$0.2	\$0.2	\$0.2	\$0.2	\$0.2	\$0.2	\$0.2	\$0.2	\$0.2	\$0.2	\$0.2	\$0.2	\$0.2	\$0.2	\$0.2	\$0.2	\$0.2	\$0.2	\$0.2
Enhance Initial Holding Pond (as back up)	\$1.0						\$1.0	\$1.0	\$1.0	\$1.0	\$1.0	\$1.0	\$1.0	\$1.0	\$1.0	\$1.0	\$1.0	\$1.0	\$1.0
Ladder to Sorting / Loading Facilities	\$8.6						\$8.6	\$8.6	\$8.6	\$8.6	\$8.6	\$8.6	\$8.6	\$8.6	\$8.6	\$8.6	\$8.6	\$8.6	\$8.6
Transport Facilities																			
Fish Ladder	\$11.7	\$11.7	\$11.7	\$11.7	\$11.7	\$11.7													
Exit Structure	\$4.9	\$4.9	\$4.9	\$4.9	\$4.9	\$4.9													
Holding / Loading Sorting Facilities (T&H Alt 2)	\$1.7												\$1.7	\$1.7	\$1.7	\$1.7	\$1.7	\$1.7	\$1.7
Fish Lift Including Exit Structure	\$3.3						\$3.3	\$3.3	\$3.3	\$3.3	\$3.3	\$3.3							
Fish Truck Loading Facility (T&H Alt 1)	\$4.2	\$4.2	\$4.2	\$4.2	\$4.2	\$4.2				\$4.2	\$4.2	\$4.2	\$4.2	\$4.2	\$4.2	\$4.2	\$4.2	\$4.2	\$4.2
Yale Dam																			
Fishway Entrance	\$7.2	\$7.2	\$7.2	\$7.2	\$7.2	\$7.2	\$7.2	\$7.2	\$7.2	\$7.2	\$7.2	\$7.2						\$7.2	\$7.2
Initial Holding Pond	\$1.6	\$1.6	\$1.6	\$1.6	\$1.6	\$1.6	\$1.6	\$1.6	\$1.6	\$1.6	\$1.6	\$1.6						\$1.6	\$1.6
Ladder to Sorting / Loading Facilities	\$1.4						\$1.4	\$1.4	\$1.4	\$1.4	\$1.4	\$1.4						\$1.4	\$1.4
Transport Facilities																			
Fish Ladder to Exit	\$9.4	\$9.4	\$9.4	\$9.4	\$9.4	\$9.4													
Exit Structure	\$5.2	\$5.2	\$5.2	\$5.2	\$5.2	\$5.2													
Holding / Loading Facilities	\$1.7									\$1.7	\$1.7	\$1.7						\$1.7	\$1.7
Fish Lift Including Exit Structure	\$4.1						\$4.1	\$4.1	\$4.1	\$4.1	\$4.1	\$4.1							
Fish Truck Loading Facility	\$4.2	\$4.2	\$4.2	\$4.2	\$4.2	\$4.2				\$4.2	\$4.2	\$4.2						\$4.2	\$4.2
Swift No. 2 Powerhouse																			
Fishway Entrance	\$3.1	\$3.1	\$3.1	\$3.1	\$3.1	\$3.1	\$3.1	\$3.1	\$3.1	\$3.1	\$3.1	\$3.1						\$3.1	\$3.1
Initial Holding Pond	\$1.0	\$1.0	\$1.0	\$1.0	\$1.0	\$1.0	\$1.0	\$1.0	\$1.0	\$1.0	\$1.0	\$1.0						\$1.0	\$1.0
Ladder to Sorting Facilities	\$1.5						\$1.5	\$1.5	\$1.5	\$1.5	\$1.5	\$1.5						\$1.5	\$1.5
Transport Facilities																			
Fish Ladder to Exit, (adult Salmonid criteria 1' step)	\$26.7	\$26.7	\$26.7	\$26.7	\$26.7	\$26.7													
Exit Structure Above Swift #1 (Existing 40' Res. Fluctuation, 1' step)	\$10.3	\$10.3	\$10.3	\$10.3	\$10.3	\$10.3													
Holding / Loading Facilities	\$1.7						\$1.7	\$1.7	\$1.7	\$1.7	\$1.7	\$1.7						\$1.7	\$1.7
Fish Lift Including Exit Structure	\$5.7						\$5.7	\$5.7	\$5.7	\$5.7	\$5.7	\$5.7							
Fish Truck Loading Facility	\$4.2	\$4.2	\$4.2	\$4.2	\$4.2	\$4.2				\$4.2	\$4.2	\$4.2						\$4.2	\$4.2
Swift No. 1 Dam																			
Fishway Entrance	\$1.1	\$1.1	\$1.1	\$1.1	\$1.1	\$1.1	\$1.1	\$1.1	\$1.1	\$1.1	\$1.1	\$1.1						\$1.1	\$1.1
Initial Holding Pond	\$1.0	\$1.0	\$1.0	\$1.0	\$1.0	\$1.0	\$1.0	\$1.0	\$1.0	\$1.0	\$1.0	\$1.0						\$1.0	\$1.0
Ladder to Sorting Facilities	\$3.0						\$3.0	\$3.0	\$3.0	\$3.0	\$3.0	\$3.0						\$3.0	\$3.0
Transport Facilities																			
Fish Ladder to Swift #2 intersect. (adult Salmonid criteria 1' step)	\$8.2	\$8.2	\$8.2	\$8.2	\$8.2	\$8.2													
Holding / Loading Facilities	\$1.7						\$1.7	\$1.7	\$1.7	\$1.7	\$1.7	\$1.7						\$1.7	\$1.7
Fish Lift Including Exit Structure	\$4.9						\$4.9	\$4.9	\$4.9	\$4.9	\$4.9	\$4.9							
Fish Truck Loading Facility	\$4.2	\$4.2	\$4.2	\$4.2	\$4.2	\$4.2				\$1.0	\$1.0	\$1.0						\$4.2	\$4.2
Subtotal, Upstream Passage Facilities		\$108.2	\$108.2	\$108.2	\$108.2	\$108.2	\$51.9	\$51.9	\$51.9	\$67.1	\$67.1	\$67.1	\$15.7	\$15.7	\$15.7	\$15.7	\$15.7	\$54.1	\$54.1
Downstream Passage Facilities																			
Swift No. 1 Dam																			
Collector																			
0.4 fps Criteria Screens (40-ft Forebay Fluctuation)	\$55.0	\$55.0														\$55.0		\$55.0	
0.8 fps Non-Criteria Screens (40-ft Forebay Fluctuation)	\$44.7		\$44.7														\$44.7		\$44.7
Modified Spillway Surface Collector (40-ft Forebay Fluctuation)	\$26.0			\$26.0			\$26.0			\$26.0			\$26.0						
Skimmer Surface Collector (40-ft Forebay Fluctuation)	\$27.5				\$27.5			\$27.5			\$27.5			\$27.5					
Gulper Surface Collector(40-ft Forebay Fluctuation)	\$26.7					\$26.7			\$26.7			\$26.7			\$26.7				
Bypass Conduit and Head Dissipation Facility	\$6.9	\$6.9	\$6.9	\$6.9	\$6.9	\$6.9	\$6.9	\$6.9	\$6.9	\$6.9	\$6.9	\$6.9						\$6.9	\$6.9
Subsampling Facility	\$15.0	\$15.0	\$15.0	\$15.0	\$15.0	\$15.0	\$15.0	\$15.0	\$15.0	\$15.0	\$15.0	\$15.0							
Sorting/Holding Facility	\$12.0									\$12.0	\$12.0	\$12.0	\$12.0	\$12.0	\$12.0	\$12.0	\$12.0		
Truck Transport Facility	\$5.0												\$5.0	\$5.0	\$5.0	\$5.0	\$5.0		
Yale Dam																			
Collector																			
Criteria Screens (16-ft Forebay Fluctuation)	\$66.0	\$66.0																\$66.0	
Non-Criteria Screens (16-ft Forebay Fluctuation)	\$54.0		\$54.0																\$54.0
Surface Collector (16-ft Forebay Fluctuation)	\$31.2			\$31.2	\$31.2	\$31.2	\$31.2	\$31.2	\$31.2	\$31.2	\$31.2	\$31.2							
Spillway Modifications	\$0.6	\$0.6	\$0.6	\$0.6	\$0.6	\$0.6	\$0.6	\$0.6	\$0.6	\$0.6	\$0.6	\$0.6	\$0.6	\$0.6	\$0.6	\$0.6	\$0.6	\$0.6	\$0.6
Bypass Conduit and Head Dissipation Facility	\$8.3	\$8.3	\$8.3	\$8.3	\$8.3	\$8.3	\$8.3	\$8.3	\$8.3	\$8.3	\$8.3	\$8.3						\$8.3	\$8.3
Subsampling Facility	\$18.0	\$18.0	\$18.0	\$18.0	\$18.0	\$18.0	\$18.0	\$18.0	\$18.0	\$18.0	\$18.0	\$18.0							
Sorting/Holding Facility	\$14.4																		
Truck Transport Facility	\$6.0																		
Merwin Dam																			
Collector																			
Criteria Screens (13-ft Forebay Fluctuation)	\$71.5	\$71.5																\$71.5	
Non-Criteria Screens (13-ft Forebay Fluctuation)	\$58.1		\$58.1																\$58.1
Surface Collector (13-ft Forebay Fluctuation)	\$33.8			\$33.8	\$33.8	\$33.8	\$33.8	\$33.8	\$33.8	\$33.8	\$33.8	\$33.8							
Bypass Conduit and Head Dissipation Facility	\$9.0	\$9.0	\$9.0	\$9.0	\$9.0	\$9.0	\$9.0	\$9.0	\$9.0	\$9.0	\$9.0	\$9.0						\$9.0	\$9.0
Subsampling Facility	\$19.5	\$19.5	\$19.5	\$19.5	\$19.5	\$19.5	\$19.5	\$19.5	\$19.5	\$19.5	\$19.5	\$19.5							
Sorting/Holding Facility	\$15.6																		
Truck Transport Facility	\$6.5																		
Lower Basin																			
Stress Relief Ponds	\$3.0	\$3.0	\$3.0	\$3.0	\$3.0	\$3.0	\$3.0	\$3.0	\$3.0	\$3.0	\$3.0	\$3.0	\$3.0	\$3.0	\$3.0	\$3.0	\$3.0	\$3.0	\$3.0
Subtotal, Downstream Passage Facilities		\$272.8	\$237.1	\$171.3	\$172.8	\$172.0	\$171.3	\$172.8	\$172.0	\$183.3	\$184.8	\$184.0	\$46.6	\$48.1	\$47.3	\$75.6	\$65.3	\$220.3	\$184.6
Total, System Passage Facilities		\$381.0	\$345.3	\$279.5	\$281.0	\$280.2	\$223.3	\$224.8	\$224.0	\$250.5	\$252.0	\$251.2	\$62.3	\$63.7	\$62.9	\$91.3	\$80.9	\$274.4	\$238.7

7.0 LITERATURE CITED

- 10,000 Years Institute and Steward and Associates. 2001. Technical Memorandum: Comparative Assessment of Risk to Migrating Salmon in the Lewis River: Volitional vs. Trap-and-Haul.
- Bell. 1986. Fisheries Handbook of Engineering Requirements and Biological Criteria. U.S. Army Corps of Engineers, North Pacific Division. Portland, OR. Milo C. Bell, 1986.
- Means, R.S. 2001. Heavy construction cost data, 15th Annual Edition. Kingston, MA.
- PacifiCorp and Cowlitz PUD. 1999, as amended. Study Plan Document for the Lewis River Hydroelectric Projects. Portland, Oregon and Longview, Washington. March 29, 1999 as amended.
- PacifiCorp and Cowlitz PUD. 2000. Fish Passage Study Working Notebook. Prepared for PacifiCorp and Cowlitz PUD by Harza Engineering Company. Bellevue, WA. September 14, 2000.
- PacifiCorp and Cowlitz PUD. 2001. AQU 5 Engineering Feasibility Study for Fish Passage Facilities, Draft Phase 1 Report. Prepared for PacifiCorp and Public Utility District No. 1 of Cowlitz County by Montgomery Watson Harza. Bellevue, WA.

Tab A

Upstream Passage Facility Drawings

FISH LADDER, FOR PROFILE
SEE DWG MU-1.2. FOR TYP
SECTIONS SEE DWG MU-1.3

MAX DESIGN EL 239.6 (FULL POOL)
MIN DESIGN EL 227.0 (UPSTREAM PASSAGE)
MIN DESIGN EL 230.0 (DOWNSTREAM PASSAGE)

RECORD LOW (1936) POOL EL 166.7
ESTIMATED FLOW LINES TO SPILLWAY, TYP

STA. 23+43 END FISH LADDER
EXIT STRUCTURE, SEE DWG MU-1.7
CONCRETE RETAINING WALL SIMILAR TO
EXTERIOR WALL OF EXIT STRUCTURE

NON-OVERFLOW SECTION, L = 208'
SPILLWAY SECTION, L = 206'
4 GATES @ 39'W X 30'H
1 GATE @ 10'W X 30'H
FISH HATCHERY
WATER SUPPLY PUMPS
THRUST BLOCK
SECTION, L = 75'
ARCH SECTION,
L = 728'

ESTIMATED FLOW LINES TO TURBINE INTAKES (DEEP), TYP

RECORD LOW (1936) POOL EL 166.7

MIN DESIGN EL 227.0 (UPSTREAM PASSAGE)
MIN DESIGN EL 230.0 (DOWNSTREAM PASSAGE)
MAX DESIGN EL 239.6 (FULL POOL)

ORIGINAL DIVERSION
TUNNEL

PLUG

STA 0+00 BEGIN FISH LADDER
SEE DWG MU-1.5
FOR LADDER ENTRANCE

MERWIN TAILWATER DESIGN ELEVATIONS
RANGE FROM 46.0 TO 54.0,
SEE DWG MU-1.4 & MU-1.5

PLAN

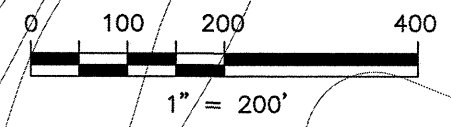

PACIFICORP LEWIS RIVER HYDRO PROJECT	FISH PASSAGE STUDY FERC No. 935
MERWIN DAM FISH LADDER PLAN	
MU-1.1	
Scale: 1" = 200' Date: FEB, 2002 File: O:\7262G\FPDR\MERWIN	Drawing
MWH	
<small>BELLEVUE, WASHINGTON (425) 602-4000</small>	

BTaylor 10/28/02 2:28 PM

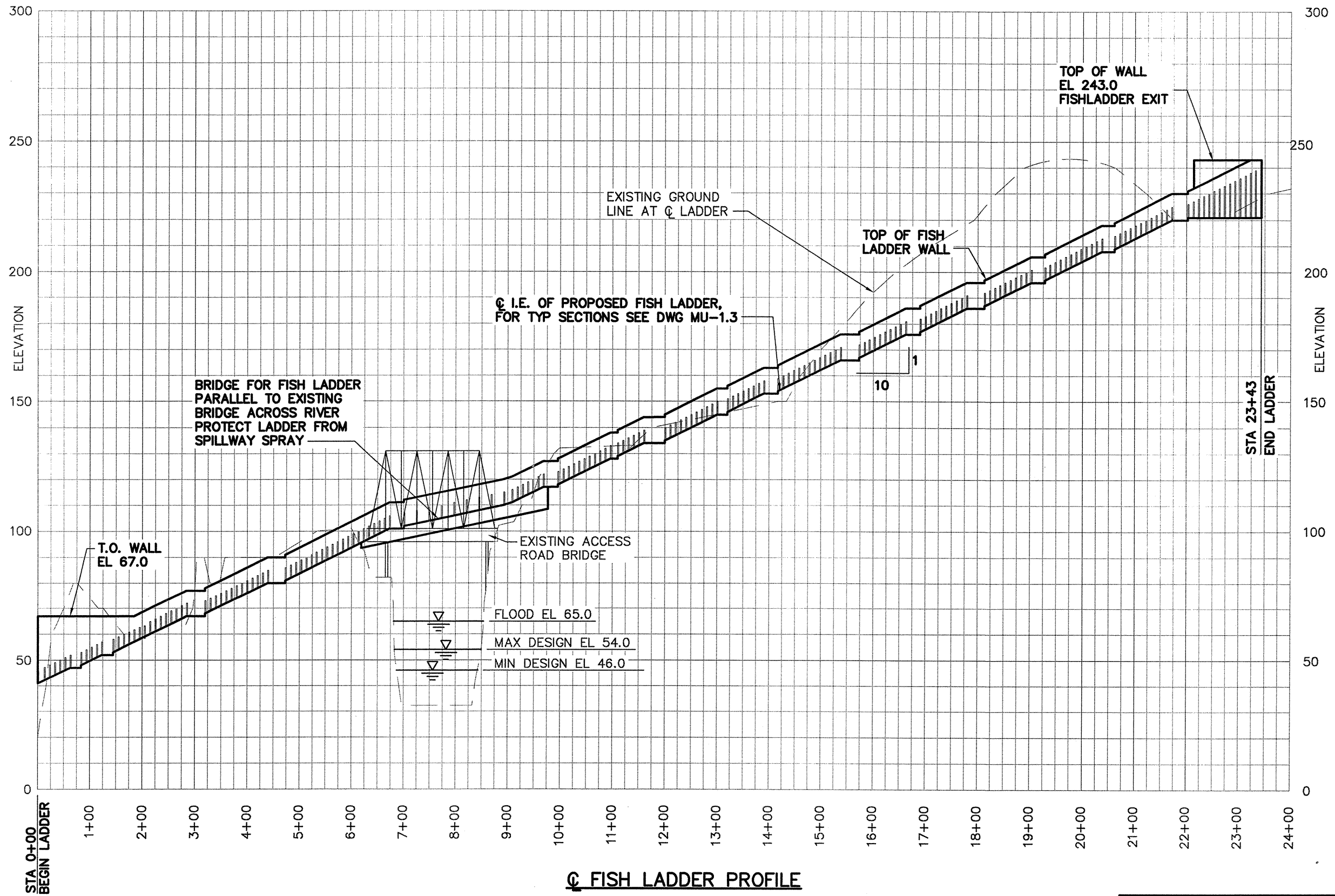

Q FISH LADDER PROFILE

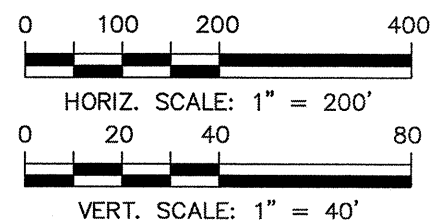

PACIFICORP FISH PASSAGE STUDY
 LEWIS RIVER HYDRO PROJECT FERC No. 935
MERWIN DAM
FISH LADDER
PROFILE
MU-1.2
 Scale: AS SHOWN
 Date: FEB, 2002
 File: O:\7262G\FPDR\MERWIN Drawing
MWH BELLEVUE, WASHINGTON (425) 802-4000

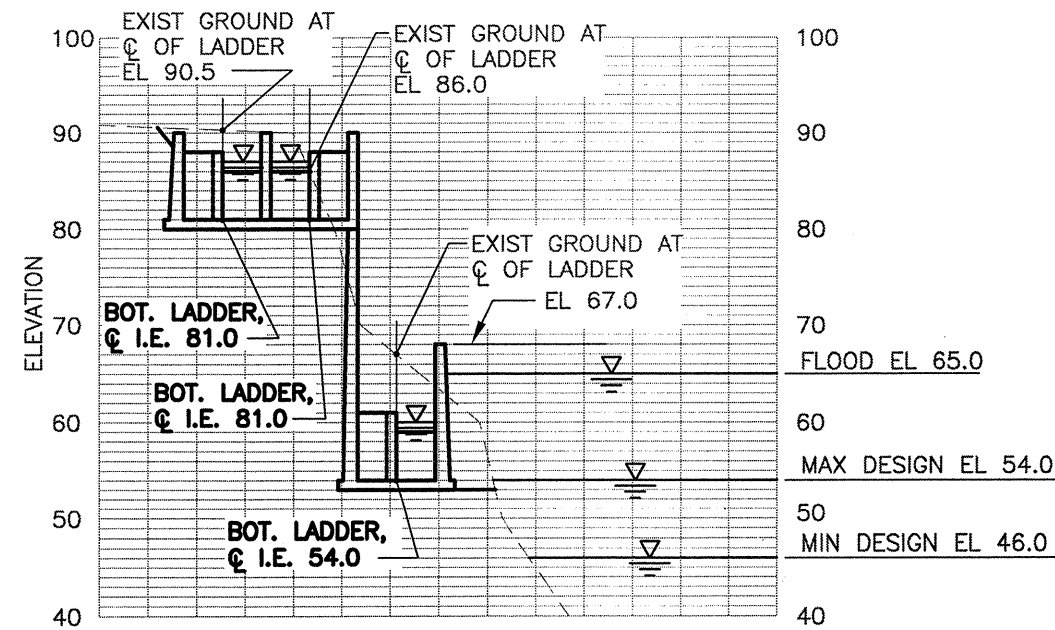

SECTION A
 APPX STA 1+50
 4+10
 4+60
 MU-1.1

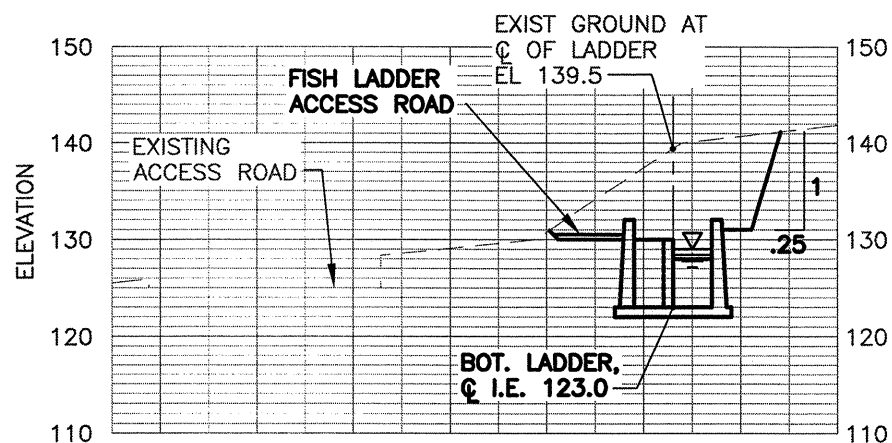
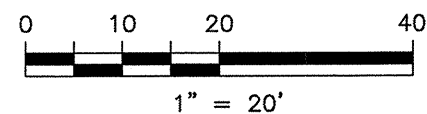

SECTION B
 APPX STA 10+40
 MU-1.1

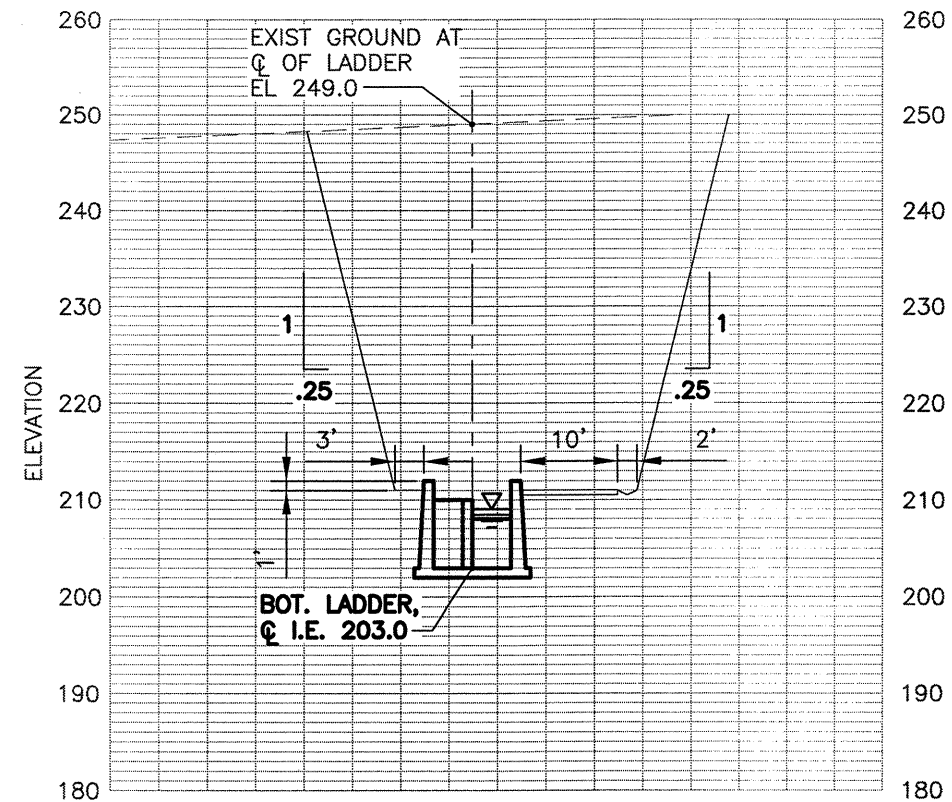

SECTION C
 APPX STA 19+95
 MU-1.1

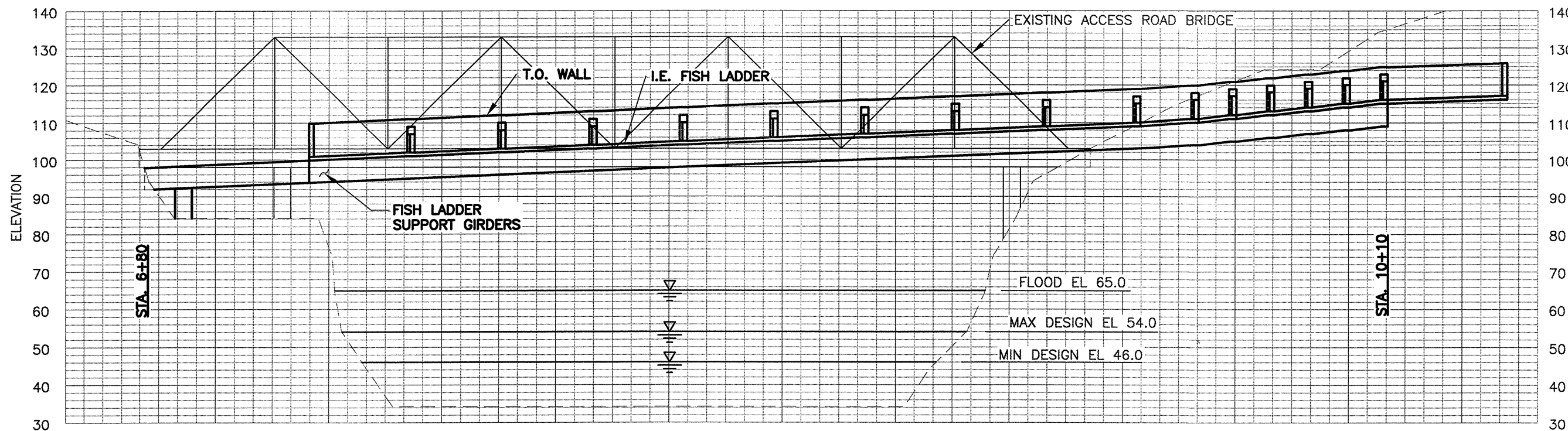

SECTION D
 BRIDGE CROSSING
 MU-1.1
 1" = 30'

NOTES:

- SECTION SHOWN TO ILLUSTRATE LOCATION RELATIVE TO EXIST GROUND. ALL CUT LINES NOT SHOWN.
- CUTS ASSUMED TO BE IN ROCK SECTIONS.
- BRIDGE AND FISH LADDER SUBJECT TO SPRAY FROM SPILLWAY, PROTECT LADDER FROM SPRAY. ALTERNATE PROTECTION POSSIBLE BY RAISING LADDER OR MOVING CROSSING DOWNSTREAM.

PACIFICORP FISH PASSAGE STUDY
 LEWIS RIVER HYDRO PROJECT FERC No. 935
MERWIN DAM
FISH LADDER SECTIONS
 Scale: 1" = 20' U.N.O.
 Date: FEB, 2002
 File: O:\7262G\FPDR\MERWIN Drawing **MU-1.4**
MWH BELLEVUE, WASHINGTON (425) 602-4000

MERWIN TAILWATER DESIGN ELEVATIONS
 • FLOOD EL 65.0
 • MAX DESIGN EL 54.0
 • MIN DESIGN EL 46.0

EXISTING FISH
 TRANSPORT TUNNEL

NOTE:
 EXISTING FISHWAY ENTRANCE ORIGINALLY
 DESIGNED TO OPERATE 3 ENTRANCES,
 ONE PER UNIT CURRENTLY CONFIGURED TO
 OPERATE ON ENTRANCE CLOSEST TO
 CONTROL BUILDING

CONSTRUCT LADDER TO
 BLOCK EXISTING FISHWAY
 ENTRANCE, SEE DWG M-2.1
 FOR DETAILS

SEE DWG MU-1.1 FOR FISH LADDER
 PLAN, AND DWG MU-1.2 FOR FISH
 LADDER PROFILE.

RECONFIGURE TRAP ENTRANCE
 TO ACCOMODATE LADDER

MIN WSEL 48.0
 MAX WSEL 55.0

RETAIN EXISTING
 FISH LIFT CAPABILITIES

POTENTIAL NEED TO
 MODIFY PUMP ROOM TO
 ACCOMMODATE LADDER
 ROUTING

STA 0+00
 BEGIN LADDER, SEE
 PROFILE DWG MU-1.2
 OLD CONTROL BUILDING
 (HISTORIC FEATURE)

ACCESS ROAD

PLAN

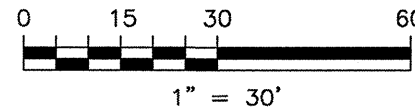

PACIFICORP FISH PASSAGE STUDY
 LEWIS RIVER HYDRO PROJECT FERC No. 935

MERWIN DAM
FISH LADDER ENTRANCE PLAN
EXISTING ENTRANCE ALT

Scale: 1" = 30'
 Date: FEB, 2002
 File: O:\7262G\FPDR\MERWIN\ Drawing MU-1.5

MWH

BELLEVUE, WASHINGTON
 (425) 602-4000

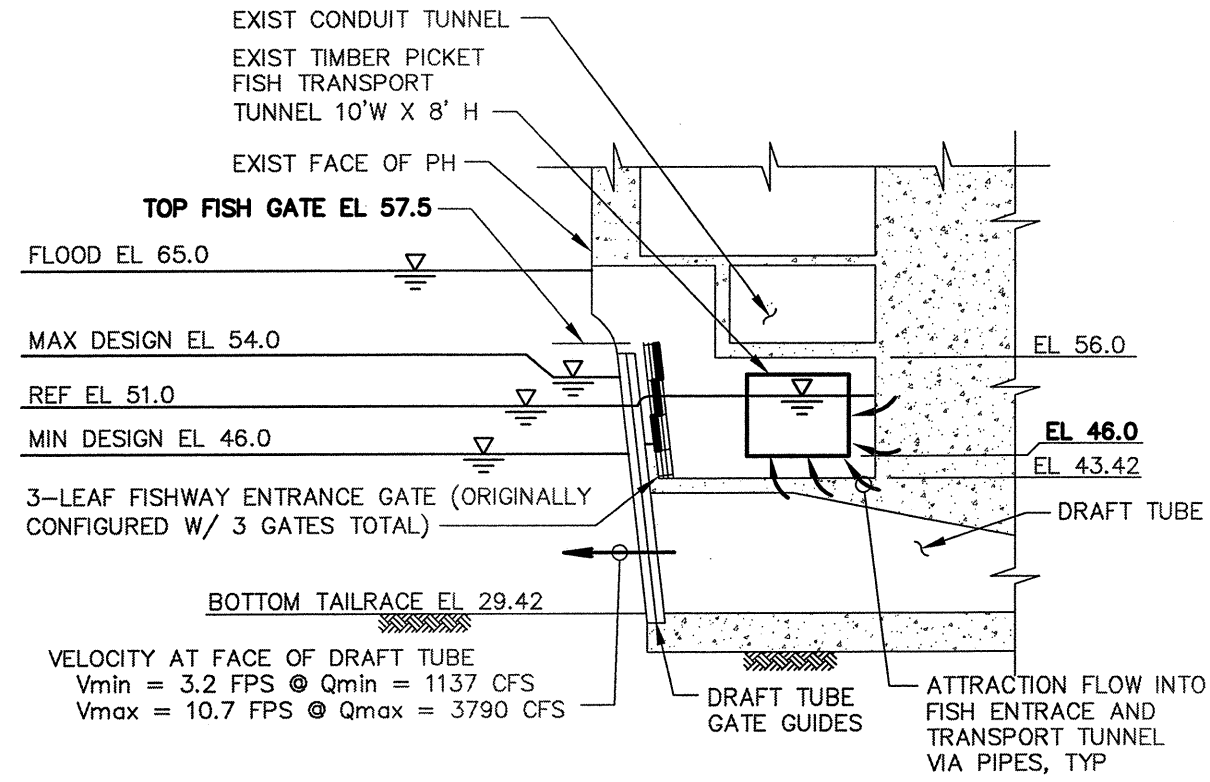

SECTION A
SECTION THRU FISHWAY ENTRANCE MU-1.5

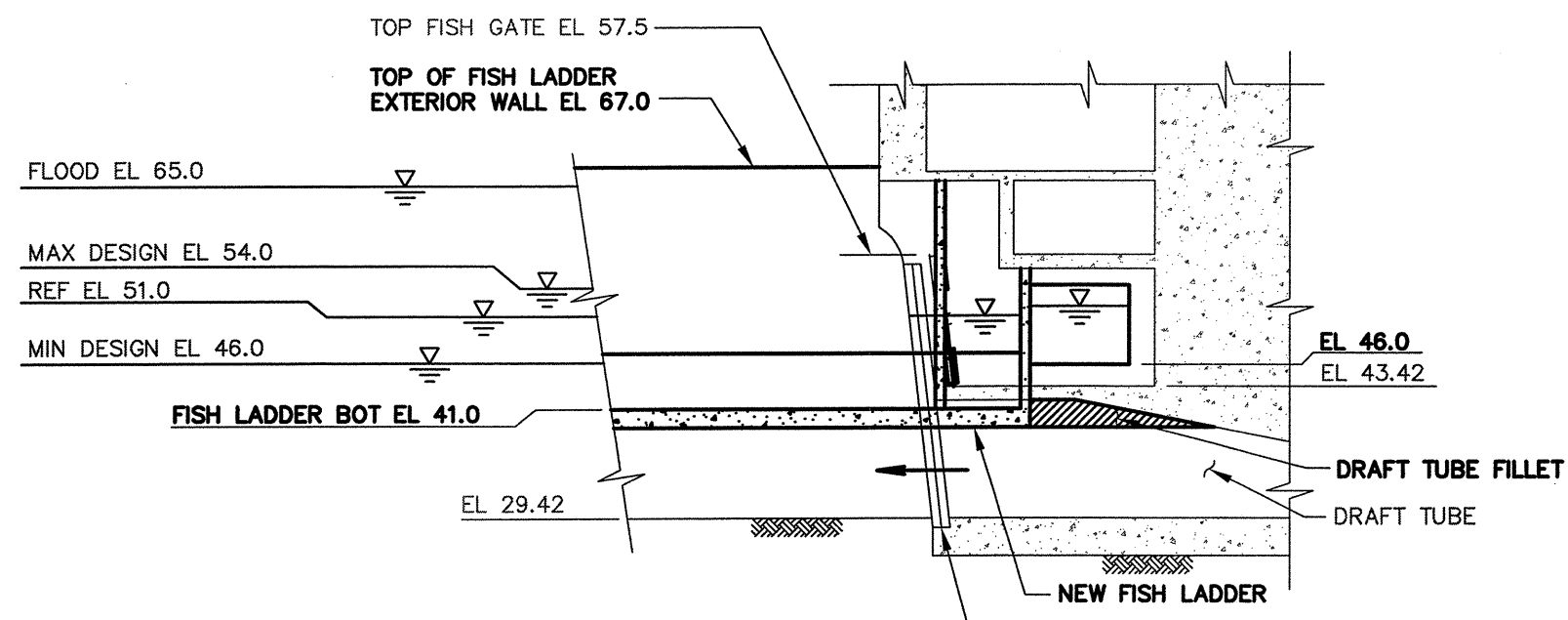

SECTION B
SECTION THRU NEW FISHLADDER MU-1.5

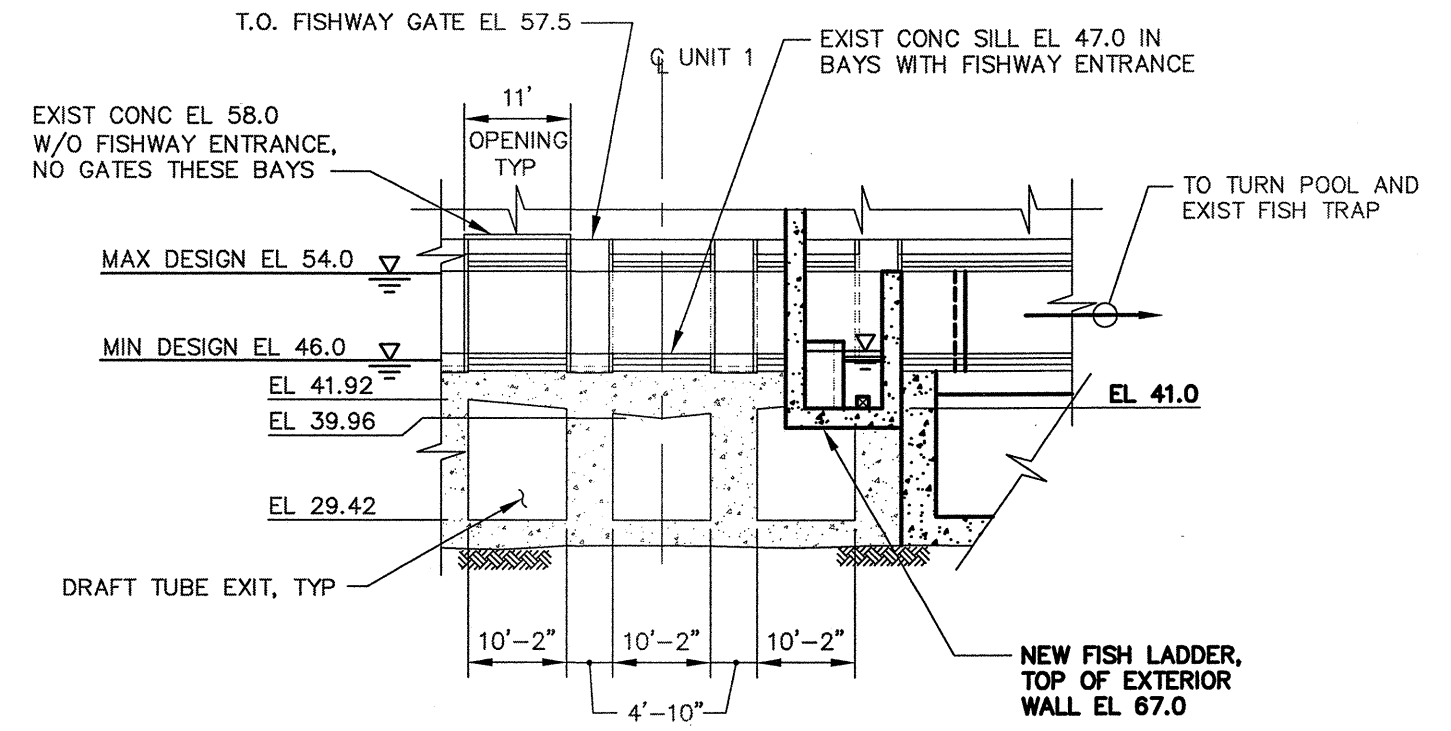

SECTION C
SECTION THRU LADDER SHOWING ELEVATION OF DRAFT TUBE EXIT MU-1.5

NOTE:
WILL REQUIRE MODIFICATION TO ONE DRAFT TUBE GATE

NOTE:
SEE DWG MU-2.2 FOR ENLARGED PLAN OF EXISTING MERWIN DAM FISHWAY ENTRANCE

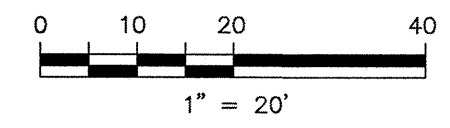

PACIFICORP LEWIS RIVER HYDRO PROJECT	FISH PASSAGE STUDY FERC No. 935
MERWIN DAM	
FISHLADDER ENTRANCE SECTIONS	
EXISTING ENTRANCE ALT	
Scale: 1"=20'	MU-1.6
Date: FEB, 2002	
File: O:\7262G\FPDR\MERWIN\ Drawing	
MWH	
<small>BELLEVUE, WASHINGTON (425) 602-4000</small>	

BTaylor 02/14/02 10:28 AM

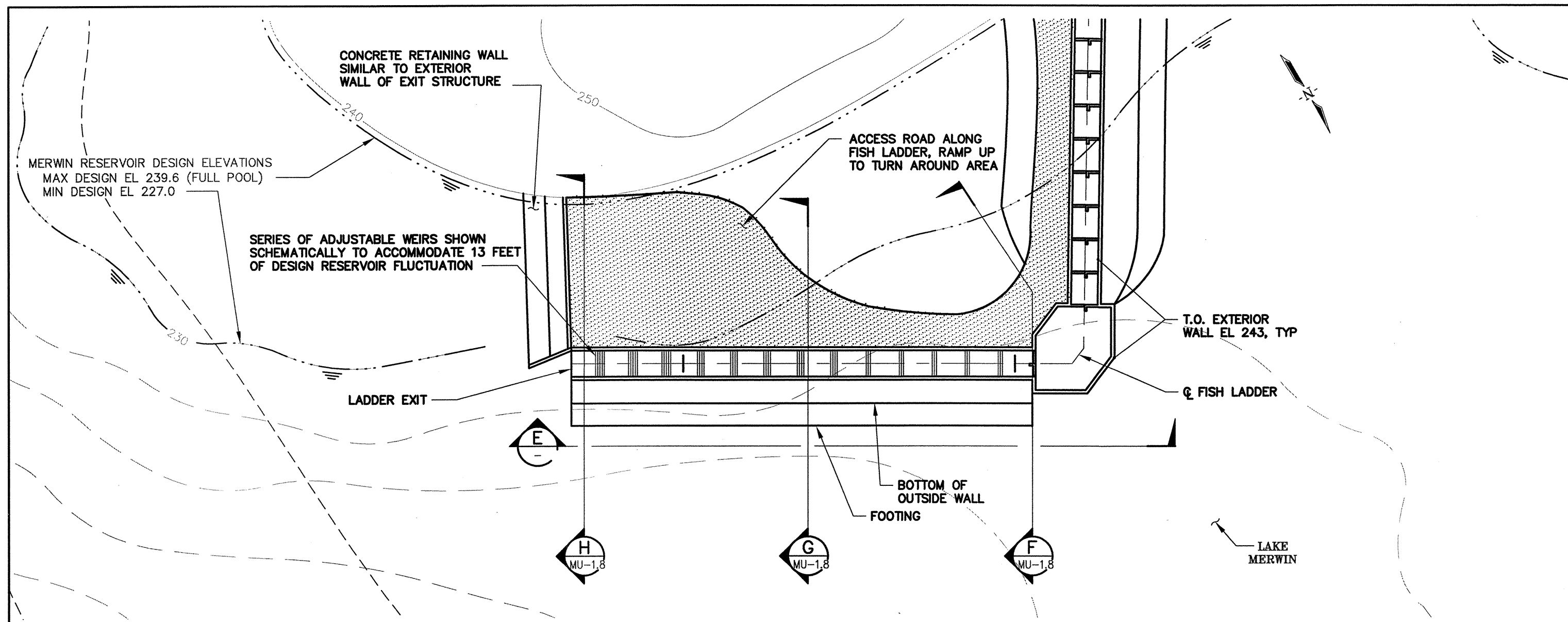

FISH LADDER EXIT PLAN

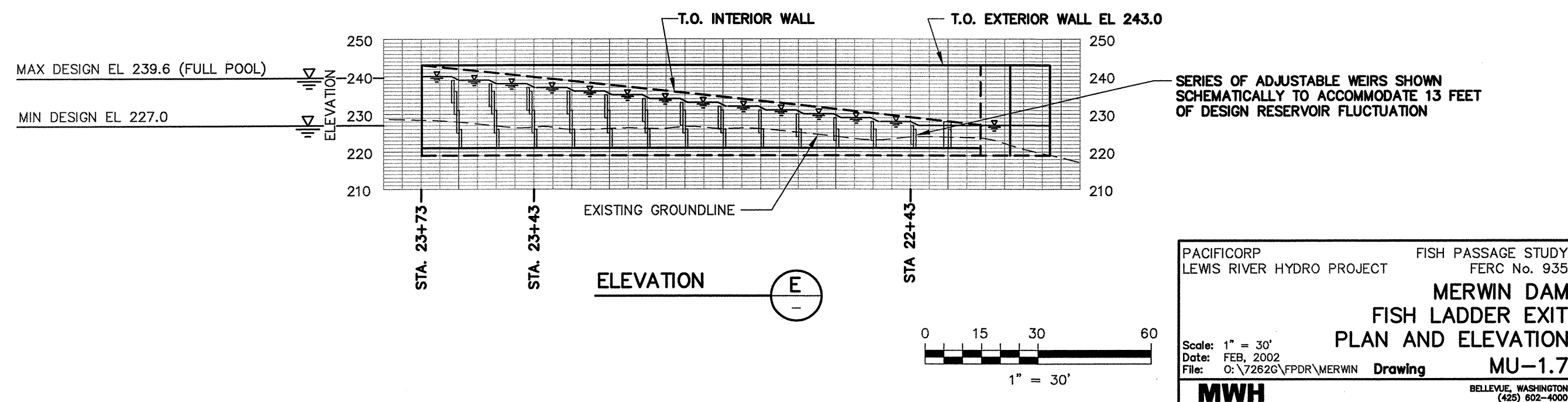

PACIFICORP FISH PASSAGE STUDY
LEWIS RIVER HYDRO PROJECT FERC No. 935

MERWIN DAM
FISH LADDER EXIT
PLAN AND ELEVATION

Scale: 1" = 30'
Date: FEB, 2002
File: O:\7262G\FPDR\MERWIN Drawing

MU-1.7

MWH
BELLEVUE, WASHINGTON
(425) 602-4000

BTaylor 02/14/02 2:21 PM

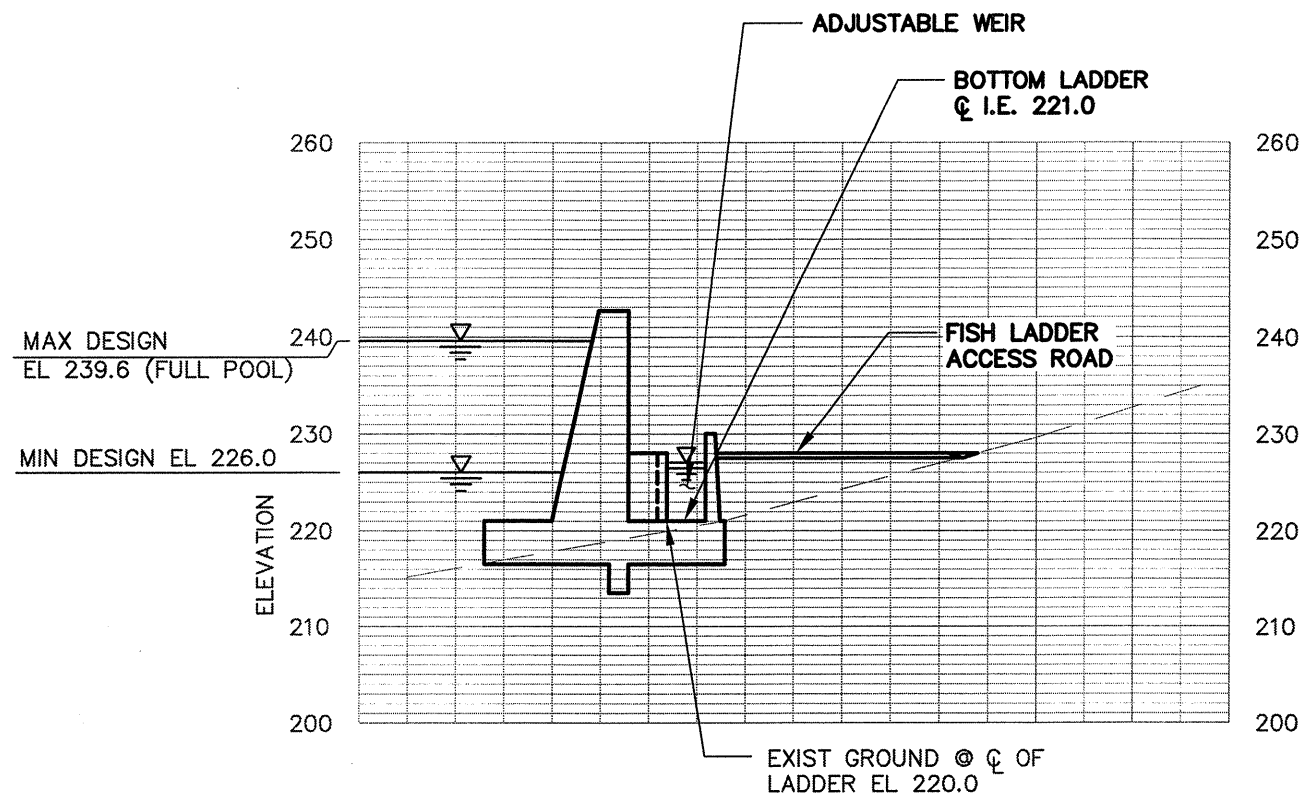

SECTION F
APPX. STA 20+90.00
MU-1.7

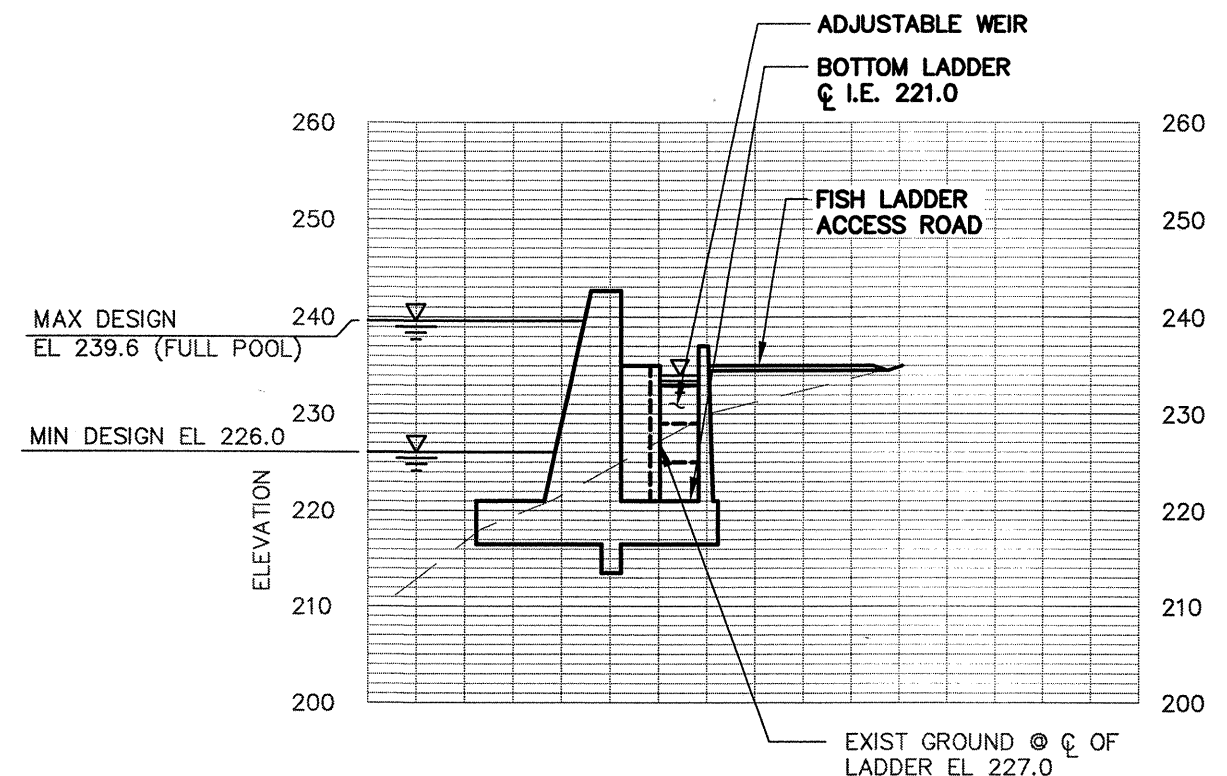

SECTION G
APPX STA 21+60.00
MU-1.7

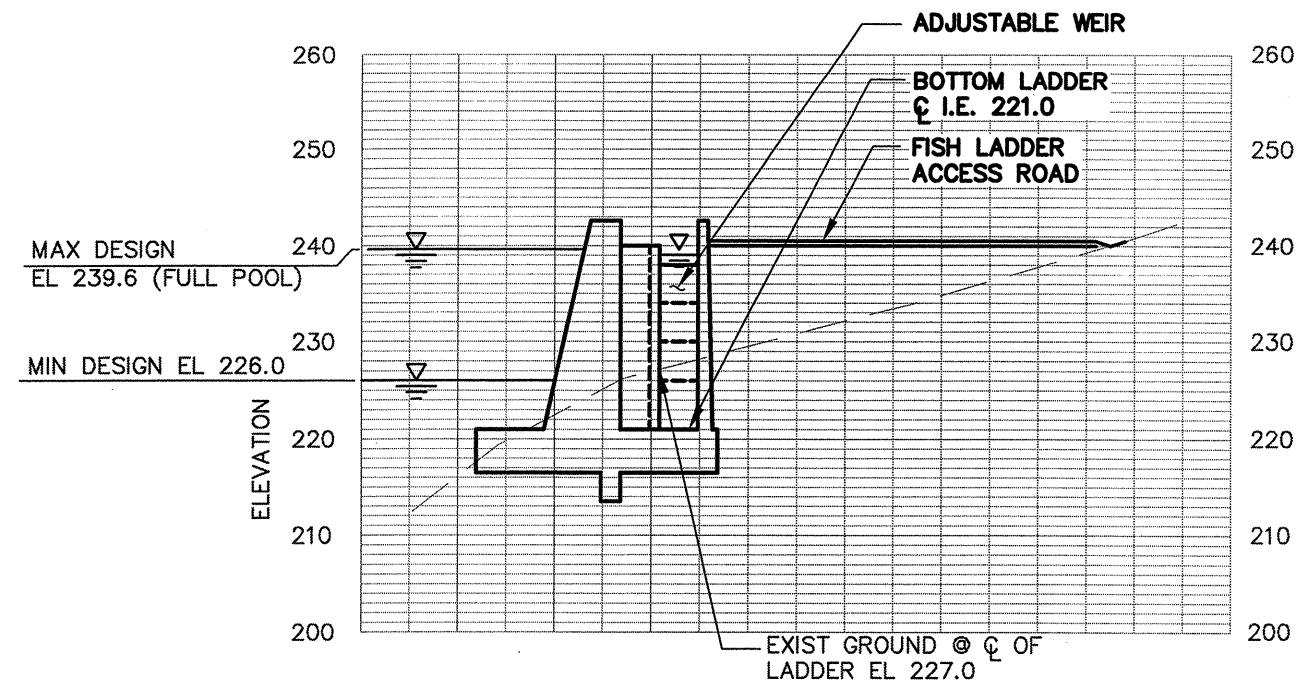

SECTION H
MU-1.7

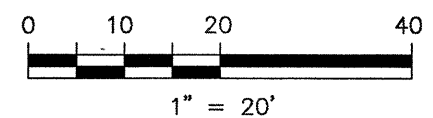

PACIFICORP LEWIS RIVER HYDRO PROJECT	FISH PASSAGE STUDY FERC No. 935
MERWIN DAM	
FISH LADDER EXIT	
SECTIONS	
Scale: 1" = 20'	MU-1.8
Date: FEB, 2002	Drawing
File: O:\7262G\FPDR\MERWIN	MWH
<small>BELLEVUE, WASHINGTON (425) 602-4000</small>	

BTaylor 02/14/02 2:26 PM

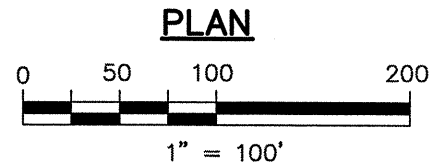
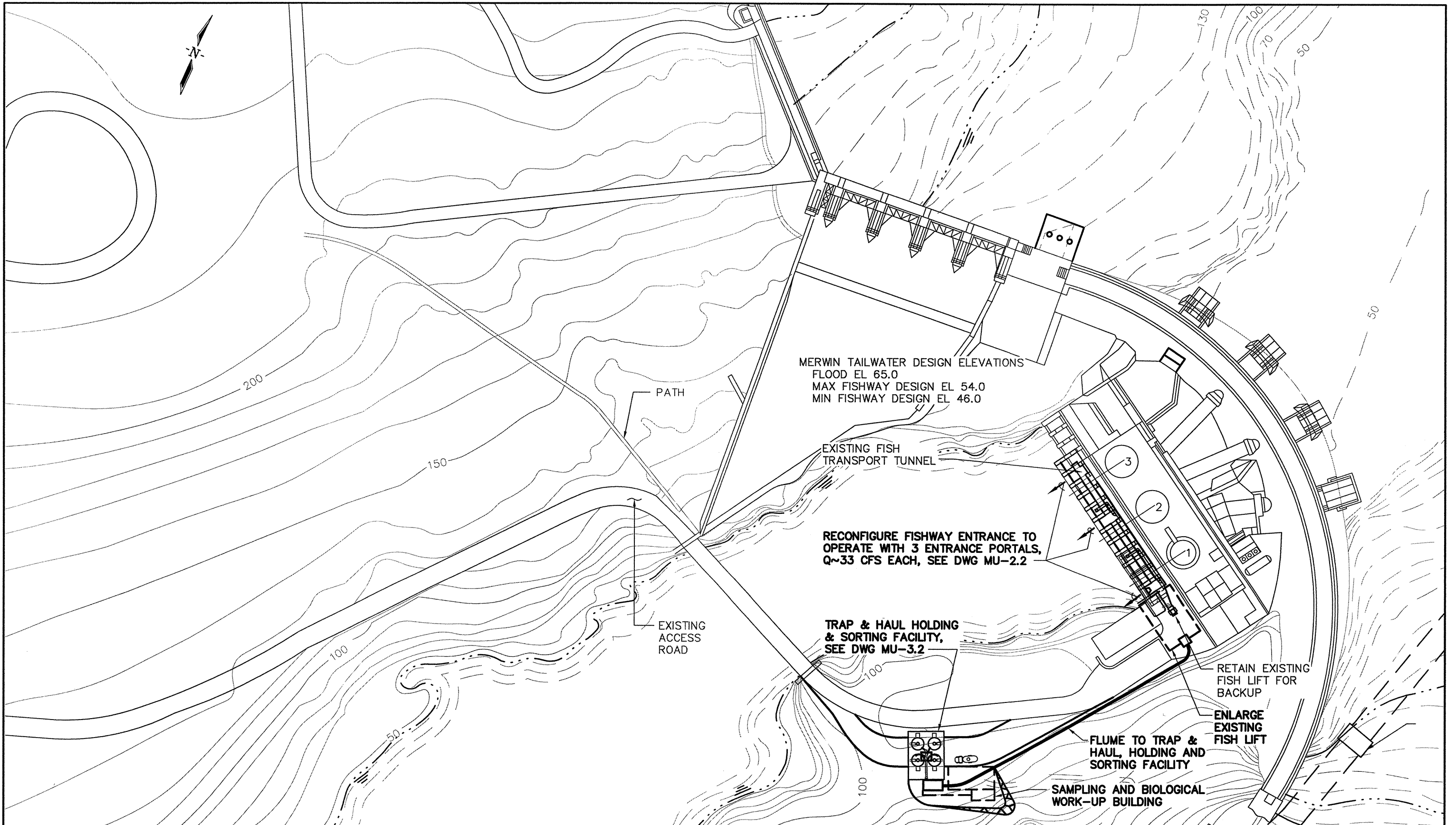

NOTES:

1. ALTERNATE LOCATION FOR SORTING/HOLDING/TRANSPORT FACILITY AT LEWIS RIVER HATCHERY.

PACIFICORP LEWIS RIVER HYDRO PROJECT	FISH PASSAGE STUDY FERC No. 935
MERWIN DAM TRAP & HAUL ALT 1 EXISTING ENTRANCE PLAN	
MU-2.1	
Scale: 1"=100' Date: APR, 2002 File: O:\7262G\FPDR\MERWIN\ Drawing	
MWH	
BELLEVUE, WASHINGTON (425) 602-4000	

BTaylor 04/18/02 07:38 AM

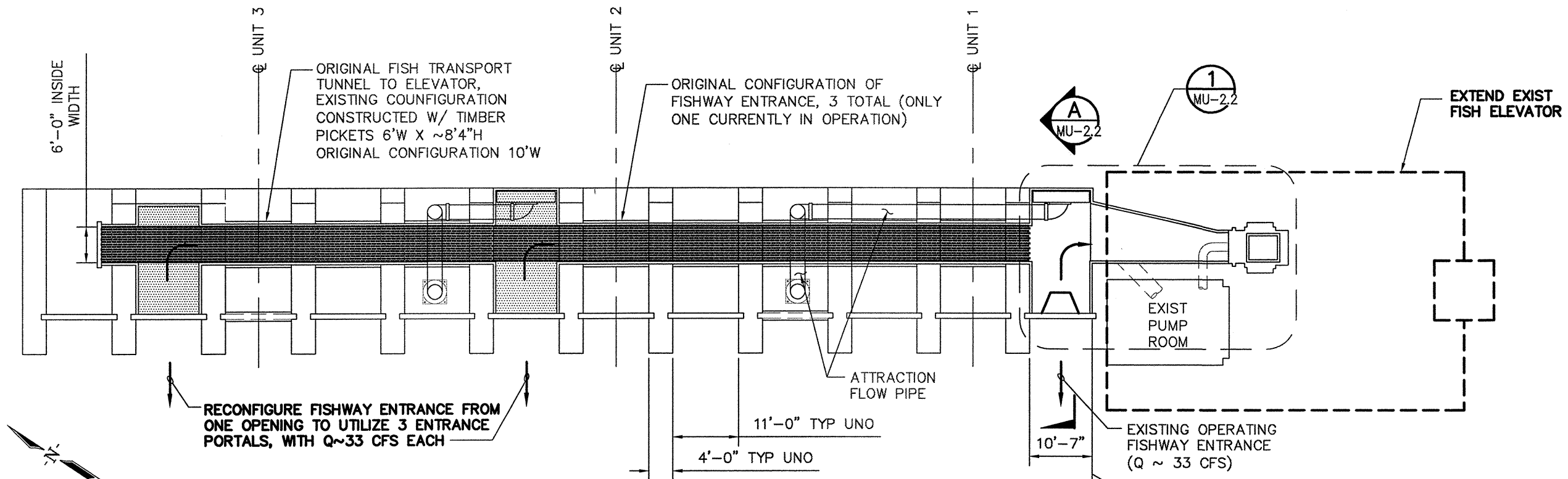

EXISTING FISHWAY ENTRANCE PLAN

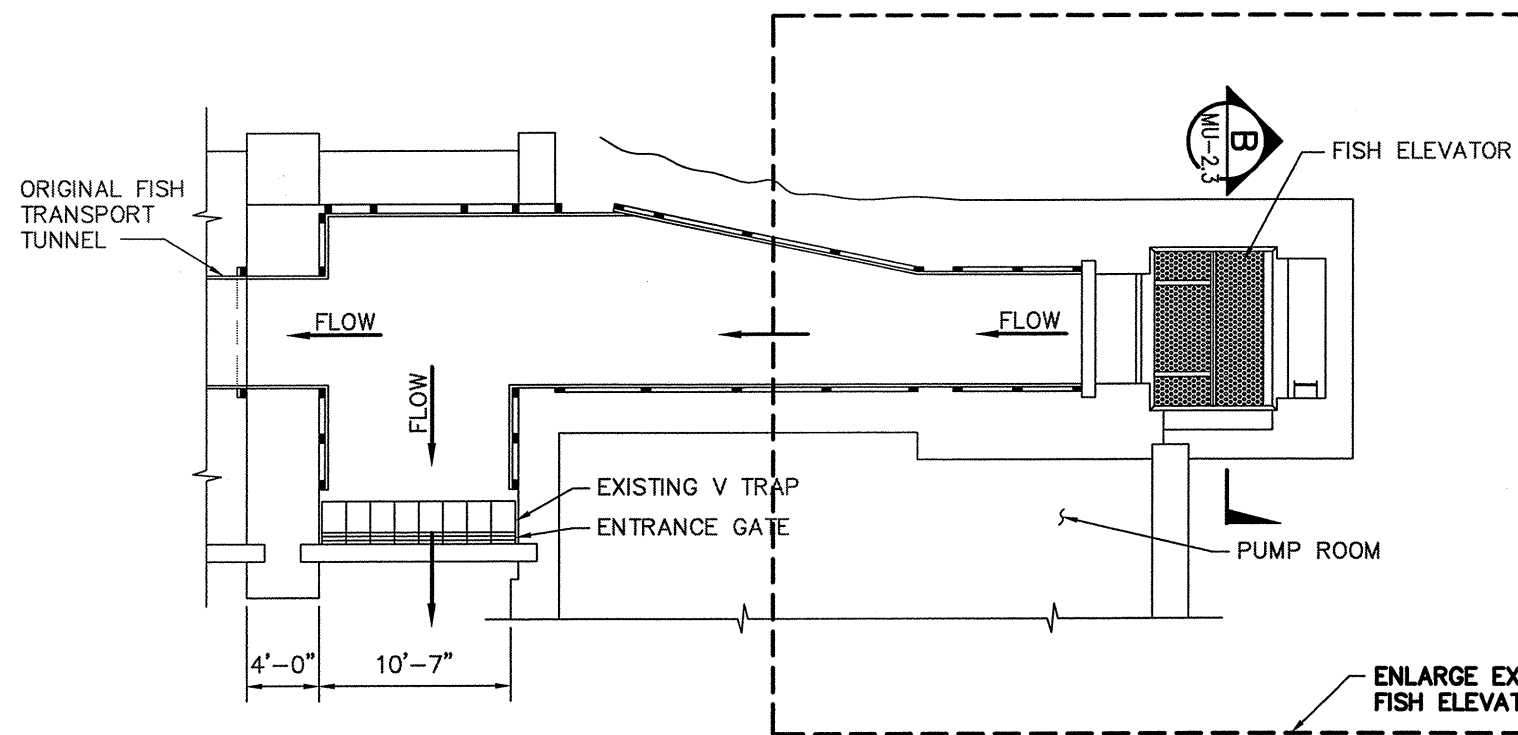

DETAIL 1
(ENLARGED PLAN OF FISHWAY ENTRANCE AND ELEVATOR)
3/32" = 1'-0"

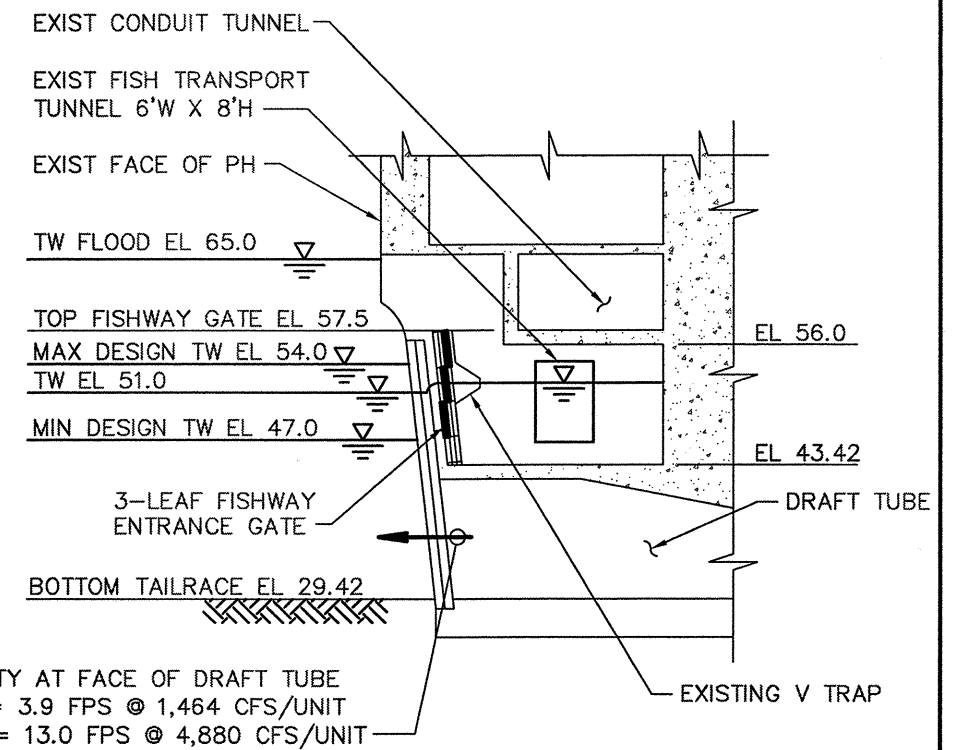

SECTION A-MU-2.2

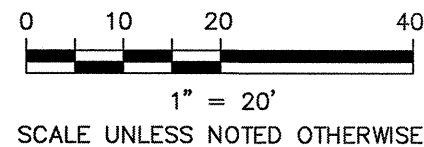

PACIFICORP FISH PASSAGE STUDY
LEWIS RIVER HYDRO PROJECT FERC No. 935

MERWIN DAM
T & H ALT 1 - EXISTING ENTRANCE DETAILS
MU-2.2

Scale: AS SHOWN
Date: APR, 2002
File: O:\7262G\FPDR\MERWIN\ Drawing

MWH BELLEVUE, WASHINGTON (425) 602-4000

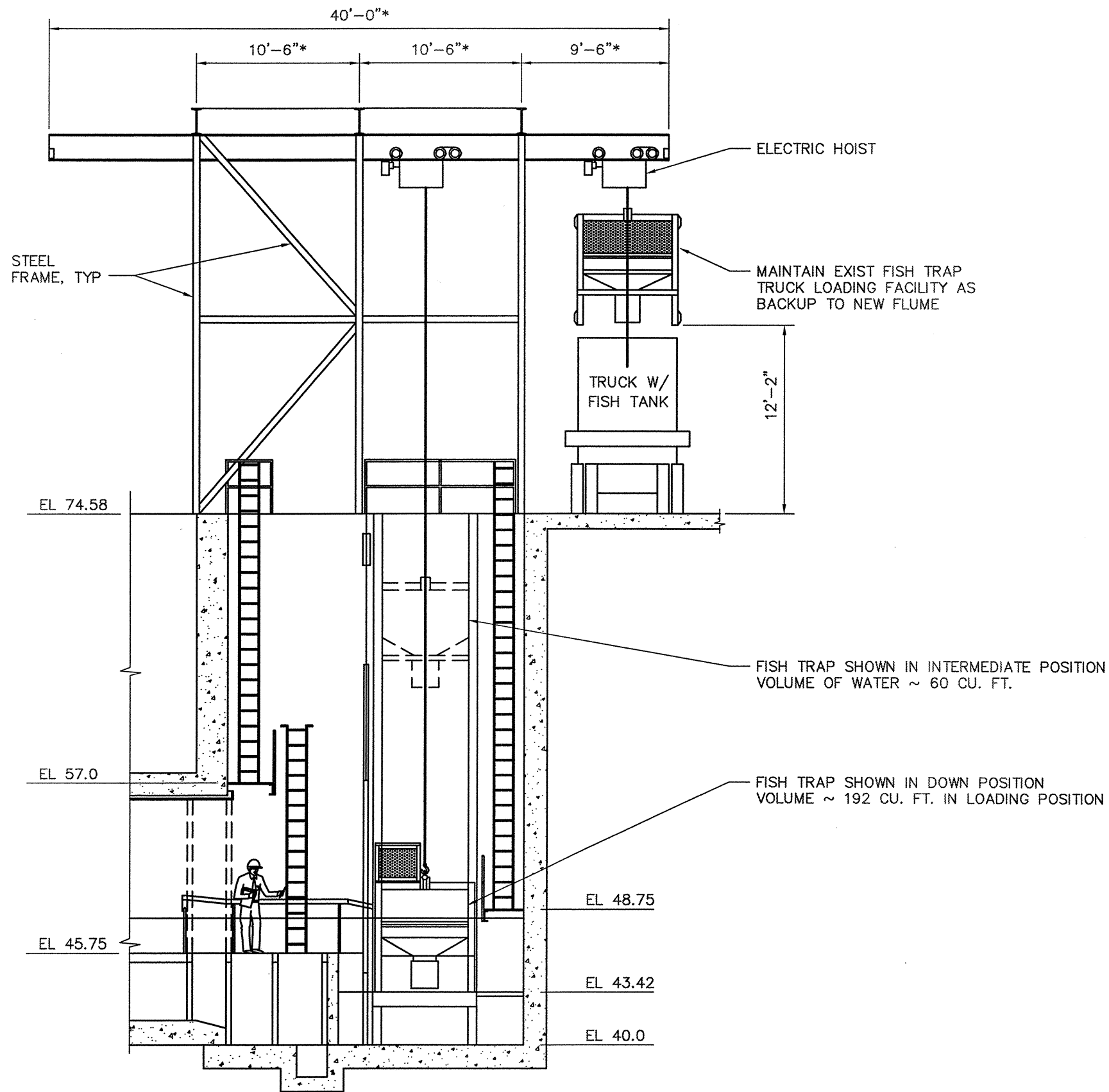

ELECTRIC HOIST

STEEL FRAME, TYP

MAINTAIN EXIST FISH TRAP TRUCK LOADING FACILITY AS BACKUP TO NEW FLUME

TRUCK W/ FISH TANK

12'-2"

EL 74.58

FISH TRAP SHOWN IN INTERMEDIATE POSITION
VOLUME OF WATER ~ 60 CU. FT.

EL 57.0

FISH TRAP SHOWN IN DOWN POSITION
VOLUME ~ 192 CU. FT. IN LOADING POSITION

EL 45.75

EL 48.75

EL 43.42

EL 40.0

NOTE: * DIMENSIONS ARE SCALED OFF DRAWING

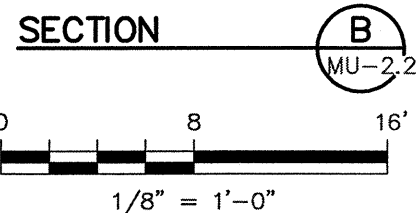

- NOTES:
1. EXISTING LIFT SHOWN FOR REFERENCE. NEW FLUME NOT SHOWN.
 2. ~ 15 MINUTES REQUIRED PER COMPLETE LOADING CYCLE.
 3. LIFT CAPACITY ~ 800 POUNDS FISH TRANSFERRED PER CYCLE.
(~60 STEELHEAD/TRUCK)
(~88 COHO/TRUCK)

PACIFICORP LEWIS RIVER HYDRO PROJECT	FISH PASSAGE STUDY F.E.R.C. No. 935
MERWIN DAM	
TRAP & HAUL ALT 1	
EXISTING LIFT SECTION	
Scale: 1/8" = 1'-0"	MU-2.3
Date: FEB, 2002	
File: O:\7262G\FPDR\MERWIN\ Drawing	
MWH	
<small>BELLEVUE, WASHINGTON (425) 602-4000</small>	

BTaylor 02/14/02 2:57 PM

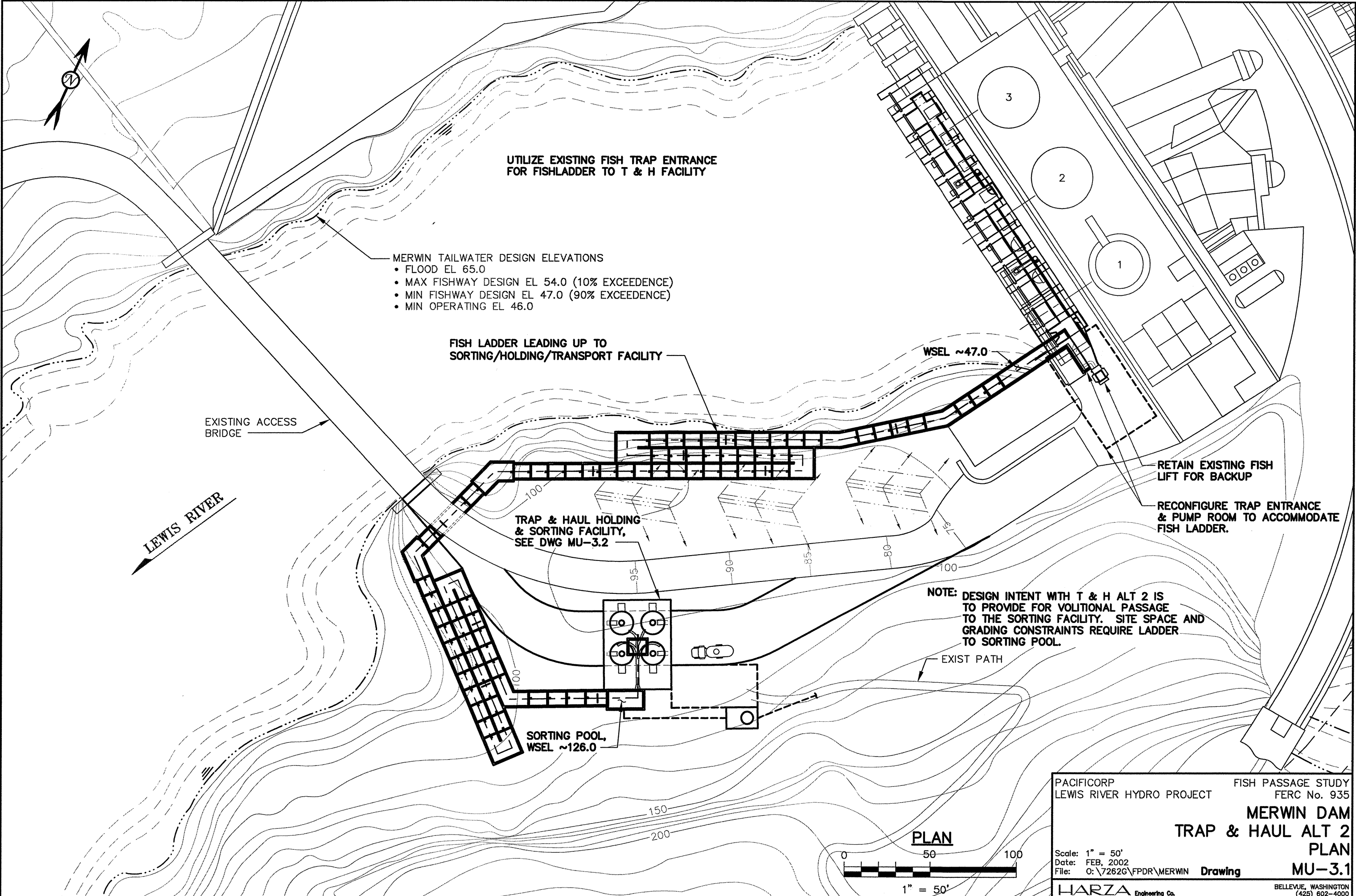

UTILIZE EXISTING FISH TRAP ENTRANCE FOR FISHLADDER TO T & H FACILITY

- MERWIN TAILWATER DESIGN ELEVATIONS
- FLOOD EL 65.0
 - MAX FISHWAY DESIGN EL 54.0 (10% EXCEEDENCE)
 - MIN FISHWAY DESIGN EL 47.0 (90% EXCEEDENCE)
 - MIN OPERATING EL 46.0

FISH LADDER LEADING UP TO SORTING/HOLDING/TRANSPORT FACILITY

WSEL ~47.0

EXISTING ACCESS BRIDGE

LEWIS RIVER

TRAP & HAUL HOLDING & SORTING FACILITY, SEE DWG MU-3.2

RETAIN EXISTING FISH LIFT FOR BACKUP

RECONFIGURE TRAP ENTRANCE & PUMP ROOM TO ACCOMMODATE FISH LADDER.

NOTE: DESIGN INTENT WITH T & H ALT 2 IS TO PROVIDE FOR VOLITIONAL PASSAGE TO THE SORTING FACILITY. SITE SPACE AND GRADING CONSTRAINTS REQUIRE LADDER TO SORTING POOL.

EXIST PATH

SORTING POOL, WSEL ~126.0

PLAN

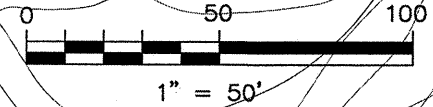

PACIFICORP LEWIS RIVER HYDRO PROJECT	FISH PASSAGE STUDY FERC No. 935
MERWIN DAM	
TRAP & HAUL ALT 2	
PLAN	
MU-3.1	
Scale: 1" = 50'	
Date: FEB, 2002	
File: O:\7262G\FPDR\MERWIN	Drawing
HARZA Engineering Co.	
BELLEVUE, WASHINGTON (425) 602-4000	

BTaylor 07/24/01 3:24 PM

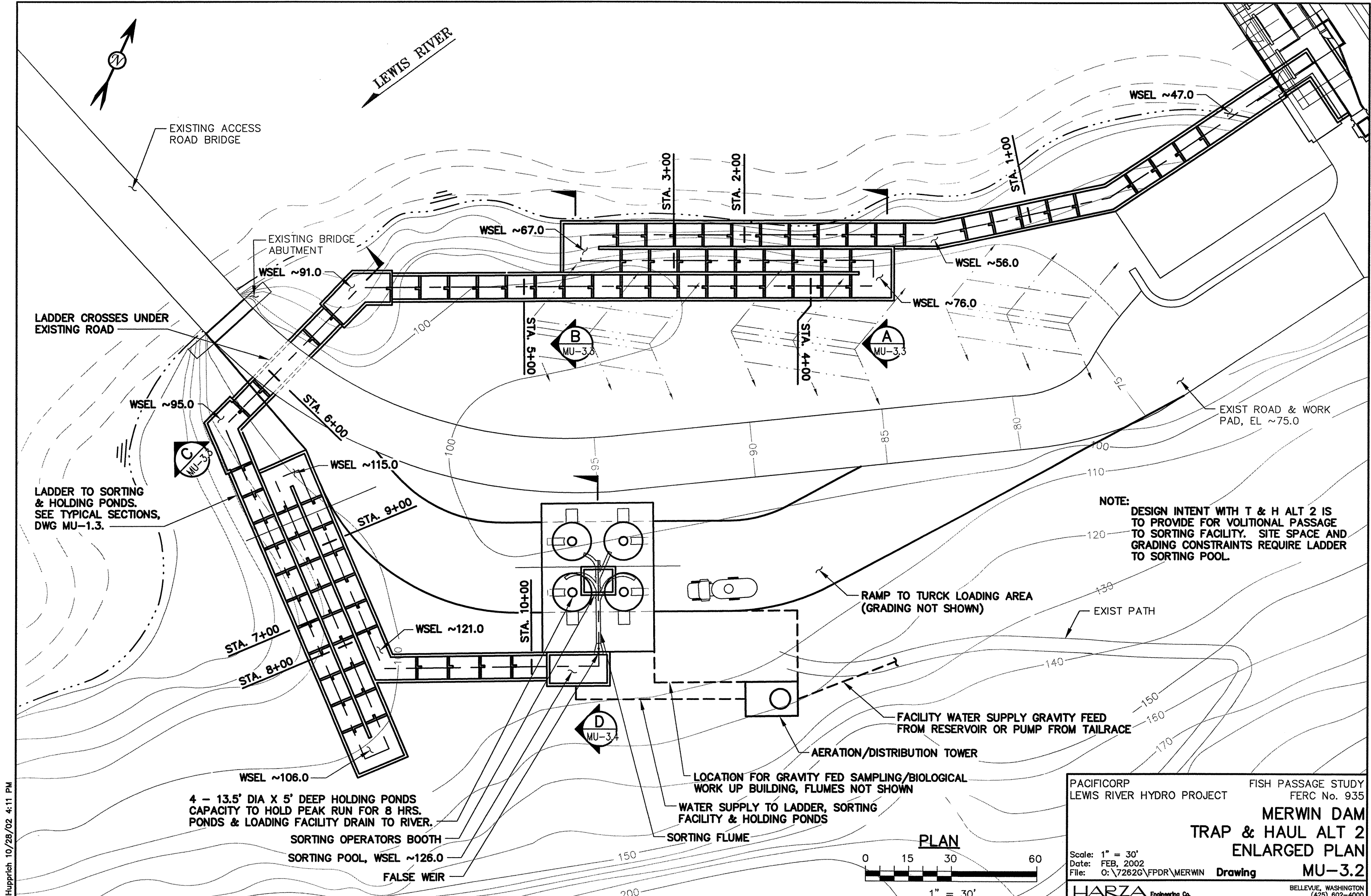

EXISTING ACCESS ROAD BRIDGE

EXISTING BRIDGE ABUTMENT

LADDER CROSSES UNDER EXISTING ROAD

LADDER TO SORTING & HOLDING PONDS. SEE TYPICAL SECTIONS, DWG MU-1.3.

NOTE: DESIGN INTENT WITH T & H ALT 2 IS TO PROVIDE FOR VOLITIONAL PASSAGE TO SORTING FACILITY. SITE SPACE AND GRADING CONSTRAINTS REQUIRE LADDER TO SORTING POOL.

RAMP TO TURCK LOADING AREA (GRADING NOT SHOWN)

FACILITY WATER SUPPLY GRAVITY FEED FROM RESERVOIR OR PUMP FROM TAILRACE

AERATION/DISTRIBUTION TOWER

LOCATION FOR GRAVITY FED SAMPLING/BIOLOGICAL WORK UP BUILDING, FLUMES NOT SHOWN

WATER SUPPLY TO LADDER, SORTING FACILITY & HOLDING PONDS

SORTING FLUME

4 - 13.5' DIA X 5' DEEP HOLDING PONDS CAPACITY TO HOLD PEAK RUN FOR 8 HRS. PONDS & LOADING FACILITY DRAIN TO RIVER.

SORTING OPERATORS BOOTH

SORTING POOL, WSEL ~126.0

FALSE WEIR

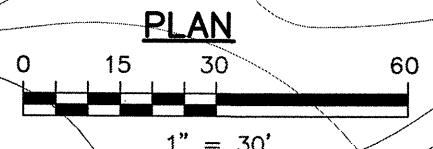

PACIFICORP LEWIS RIVER HYDRO PROJECT	FISH PASSAGE STUDY FERC No. 935
MERWIN DAM TRAP & HAUL ALT 2 ENLARGED PLAN	
Scale: 1" = 30' Date: FEB, 2002 File: O:\7262G\FPDR\MERWIN	Drawing MU-3.2
HARZA Engineering Co.	
BELLEVUE, WASHINGTON (425) 602-4000	

N:\upprich 10/28/02 4:11 PM

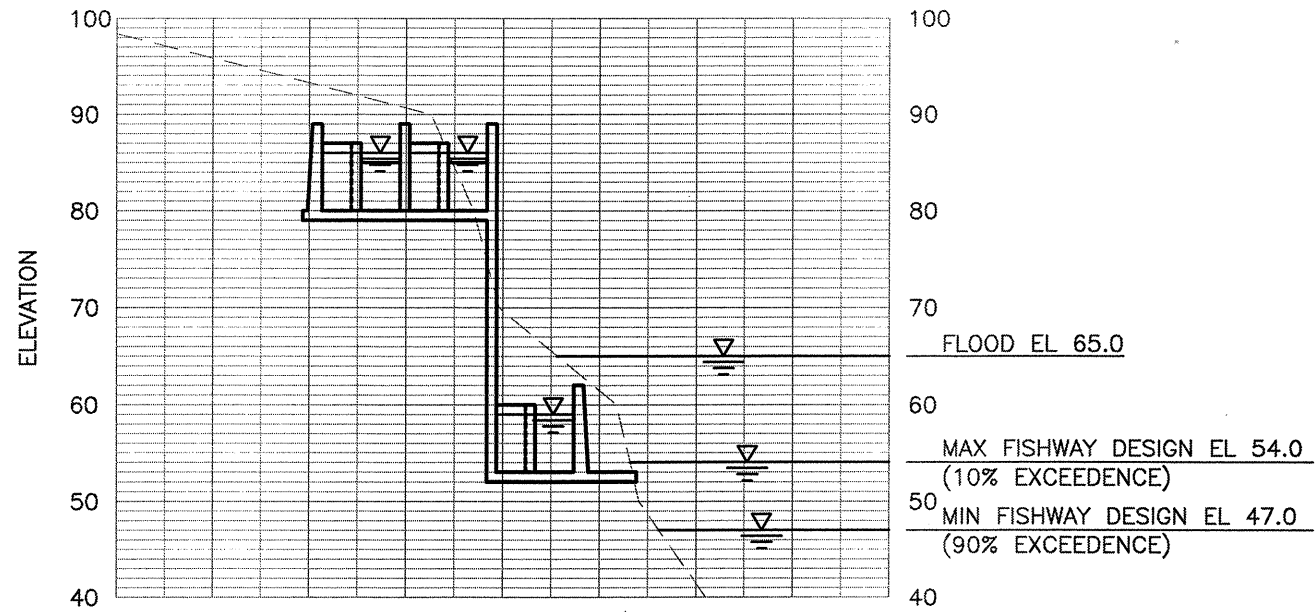

SECTION **A**
MU-3.2

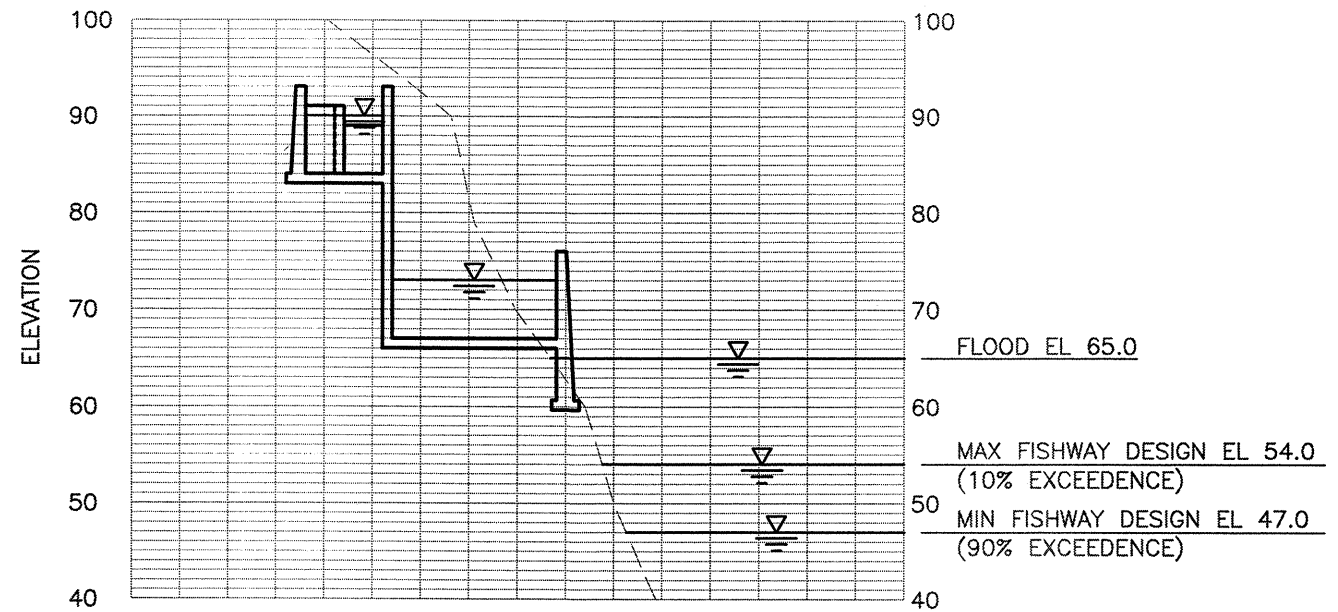

SECTION **B**
MU-3.2

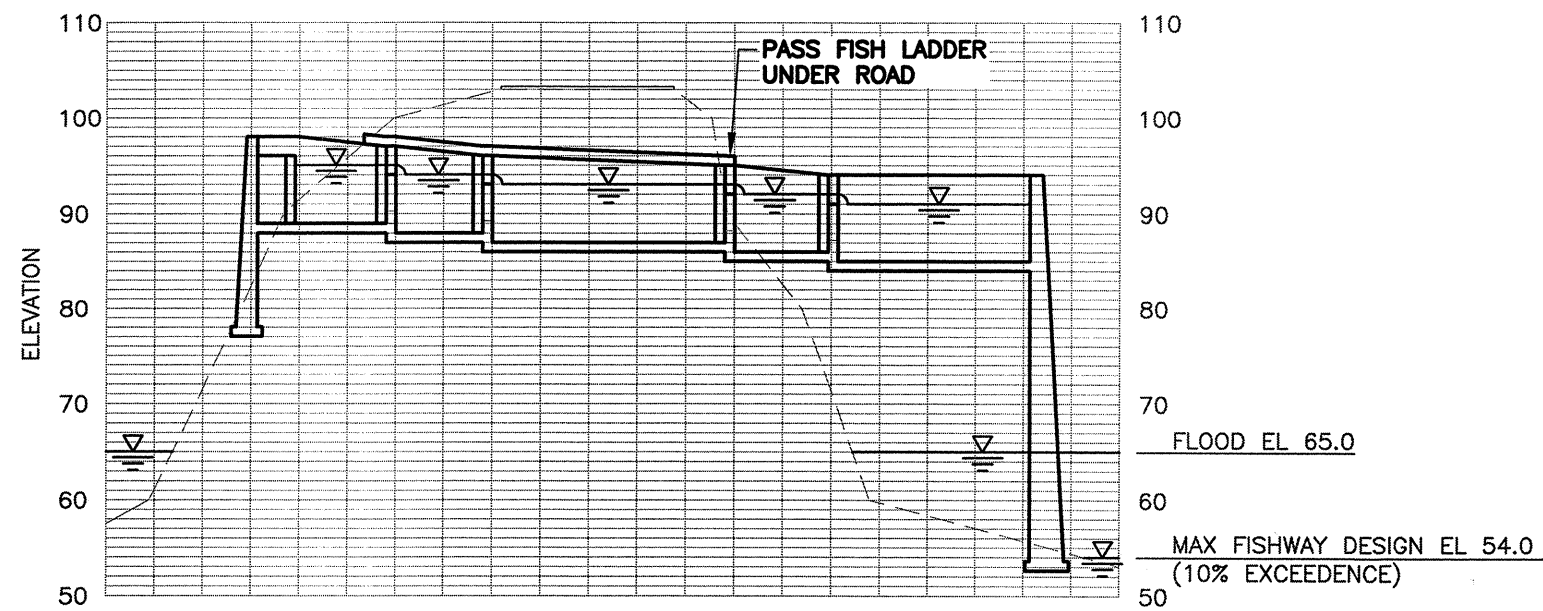

SECTION **C**
MU-3.2

NOTE:
ALIGNMENTS CAN BE ADJUSTED ON PLAN, DWG MU-3.2
TO MINIMIZE NEED FOR WALL SUPPORTS, EXCAVATION
& FILL. SECTIONS INTENDED TO COMMUNICATE
FUNCTIONAL DESIGN AND ILLUSTRATE DESIGN ISSUES.

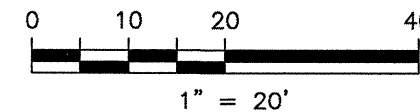

PACIFICORP LEWIS RIVER HYDRO PROJECT	FISH PASSAGE STUDY FERC No. 935
MERWIN DAM	
TRAP & HAUL ALT 2	
SECTIONS	
MU-3.3	
Scale: 1" = 20' Date: FEB, 2002 File: O:\7262G\FPDR\MERWIN	Drawing
HARZA Engineering Co.	
<small>BELLEVUE, WASHINGTON (425) 802-4000</small>	

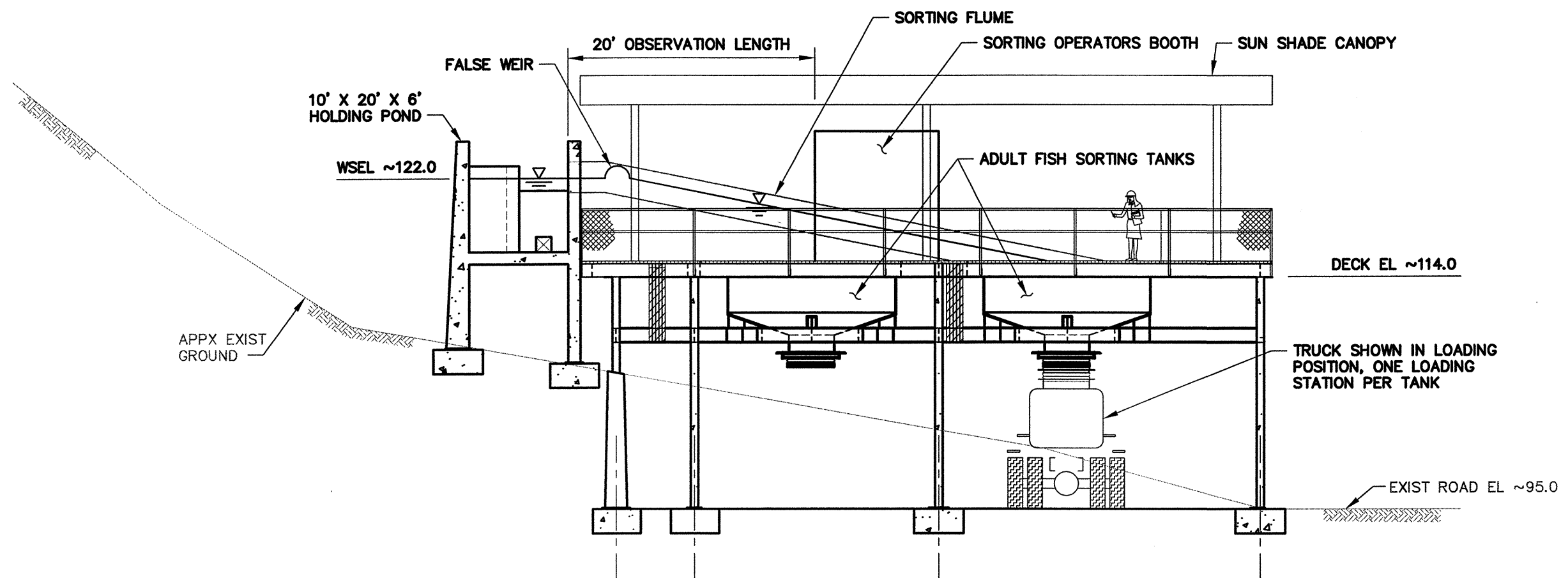

SECTION D
 MU-3.2
 SCHEMATIC SECTION
 SUPPORT MEMBERS NOT SHOWN
 FOR CLARITY

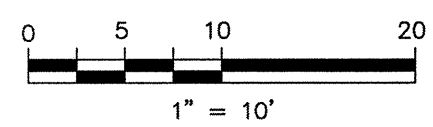

PACIFICORP LEWIS RIVER HYDRO PROJECT	FISH PASSAGE STUDY FERC No. 935
MERWIN DAM	
TRAP AND HAUL ALT 2, TRANSFER FACILITY SECTION	
Scale: 1" = 10' Date: FEB, 2002 File: O:\7262G\FPDR\MERWIN	Drawing MU-3.4
HARZA Engineering Co.	
<small>BELLEVUE, WASHINGTON (425) 602-4000</small>	

NHuppich 10/28/02 4:15 PM

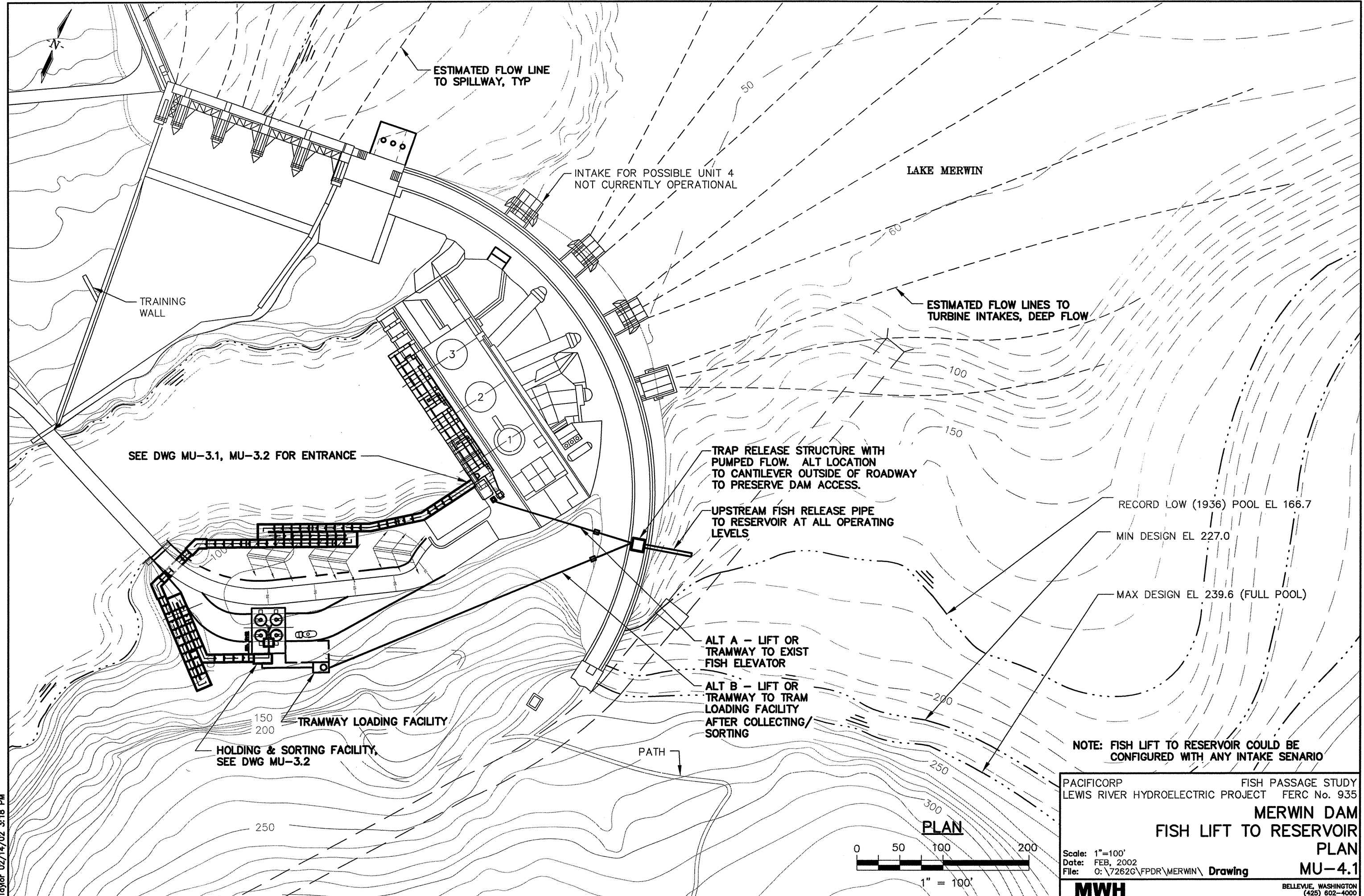

ESTIMATED FLOW LINE TO SPILLWAY, TYP

INTAKE FOR POSSIBLE UNIT 4 NOT CURRENTLY OPERATIONAL

LAKE MERWIN

ESTIMATED FLOW LINES TO TURBINE INTAKES, DEEP FLOW

TRAINING WALL

SEE DWG MU-3.1, MU-3.2 FOR ENTRANCE

TRAP RELEASE STRUCTURE WITH PUMPED FLOW. ALT LOCATION TO CANTILEVER OUTSIDE OF ROADWAY TO PRESERVE DAM ACCESS.

UPSTREAM FISH RELEASE PIPE TO RESERVOIR AT ALL OPERATING LEVELS

RECORD LOW (1936) POOL EL 166.7

MIN DESIGN EL 227.0

MAX DESIGN EL 239.6 (FULL POOL)

ALT A - LIFT OR TRAMWAY TO EXIST FISH ELEVATOR

ALT B - LIFT OR TRAMWAY TO TRAM LOADING FACILITY AFTER COLLECTING/SORTING

NOTE: FISH LIFT TO RESERVOIR COULD BE CONFIGURED WITH ANY INTAKE SENARIO

TRAMWAY LOADING FACILITY

HOLDING & SORTING FACILITY, SEE DWG MU-3.2

PATH

PLAN

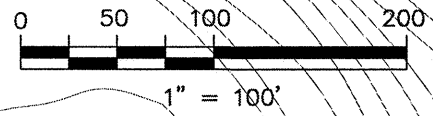

PACIFICORP FISH PASSAGE STUDY
 LEWIS RIVER HYDROELECTRIC PROJECT FERC No. 935

MERWIN DAM
FISH LIFT TO RESERVOIR
PLAN

Scale: 1"=100'
 Date: FEB, 2002
 File: O:\7262G\FPDR\MERWIN\ Drawing

MU-4.1

MWH
 BELLEVUE, WASHINGTON
 (425) 602-4000

BTaylor 02/14/02 3:18 PM



FISH LADDER, FOR PROFILE SEE DWG YU-1.2, FOR TYP SECTIONS SEE DWG MU-1.3

NOTE UNSTABLE ROCK IN AREA ALONG SPILLWAY CHANNEL

STATION 26+80, EL 473.0 END FISH LADDER AND BEGIN FISHWAY

TURNING/RESTING POOL, TYP

SPILLWAY CHANNEL MODIFICATION, 5' WIDE CHANNEL THROUGH ROCK OUTCROP

ROCK OUTCROP

YALE TAILWATER ELEVATIONS RANGE FROM 231.5 TO 240.0 SEE DWG YU-1.4

LEWIS RIVER

ACCESS ROAD

STA 0+00 BEGIN FISH LADDER SEE DWG YU-1.4 FOR LADDER ENTRANCE

CONCRETE RETAINING WALL SIMILAR TO EXTERIOR WALL OF EXIT STRUCTURE

STATION 36+00

SPILLWAY CREST EL 460.0
5 GATES @ 39'W X 30'H
MAX DESIGN EL 490.0 (FULL POOL)
MIN DESIGN EL 474.0
MIN OPERATING EL 430.0

STATION 31+00

STATION 26+00

STATION 20+00

STATION 15+00

STATION 10+00

STATION 5+00

18'-6" DIA. INTAKE TUNNELS

SWITCHYARD AREA

YALE LAKE

TUNNEL PLUG
30'-0" DAM DIVERSION TUNNEL

SLOPE 2 ON 1

SLOPE 2 ON 1

INTAKE

MAX DESIGN EL 490.0 (FULL POOL)
MIN DESIGN EL 474.0
MIN OPERATING EL 430.0

NOTE: SEE DWG MU-1.3 FOR FISH LADDER TYPICAL SECTION

PLAN

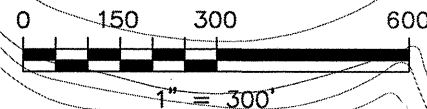

PACIFICORP LEWIS RIVER HYDRO PROJECT

FISH PASSAGE STUDY
FERC No 2071

YALE DAM
FISH LADDER

PLAN

YU-1.1

Scale: 1" = 300'
Date: APR, 2002
File: O:\7262G\FPDR\YALE

Drawing

MWH

BELLEVUE, WASHINGTON
(425) 602-4000

BTaylor 10/28/02 2:10 PM

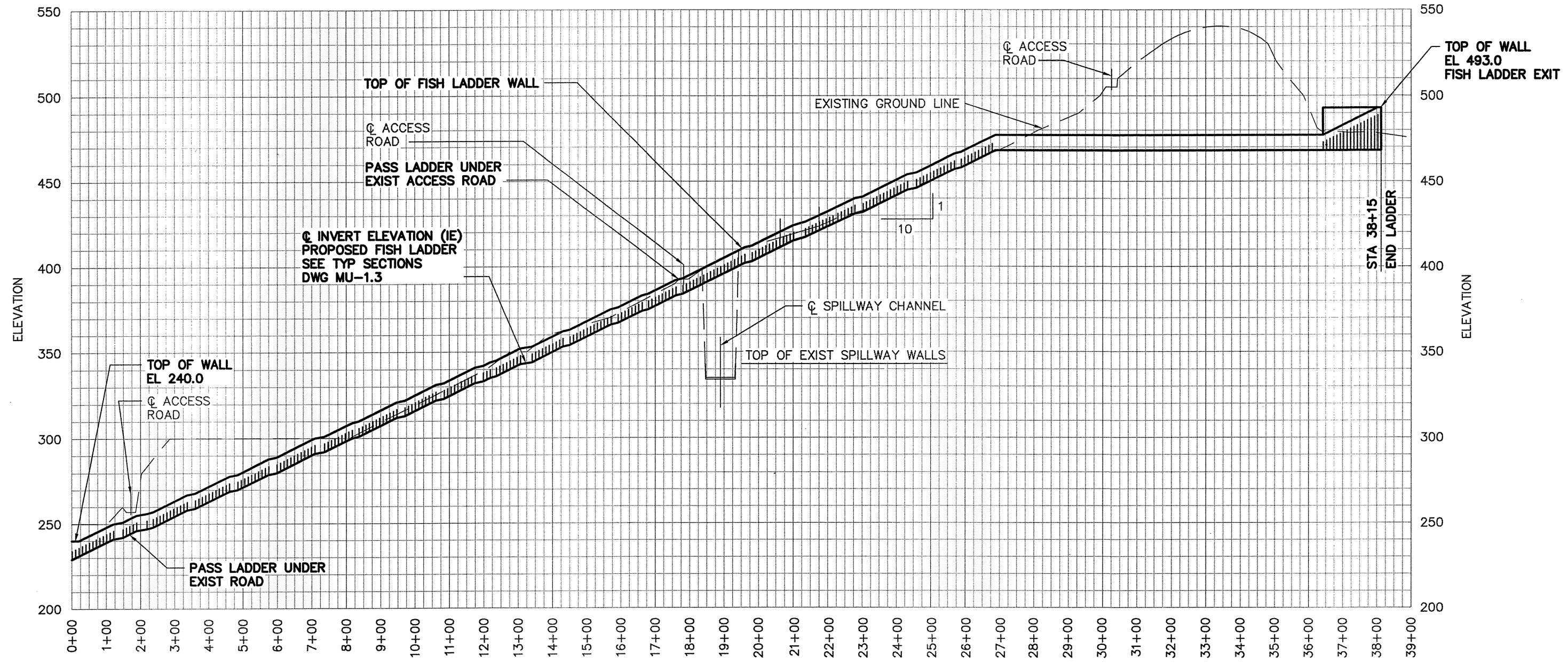

FISH LADDER PROFILE

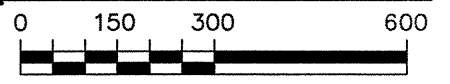

HORIZ. SCALE: 1" = 300'

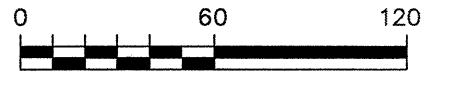

VERT. SCALE: 1" = 60'

PACIFICORP LEWIS RIVER HYDRO PROJECT	FISH PASSAGE STUDY FERC No 2071
YALE DAM FISH LADDER PROFILE	
Scale: AS SHOWN Date: FEB, 2002 File: O:\7262G\FPDR\YALE	Drawing: YU-1.2
MWH BELLEVUE, WASHINGTON (425) 602-4000	

BTaylor 10/28/02 2:12 PM

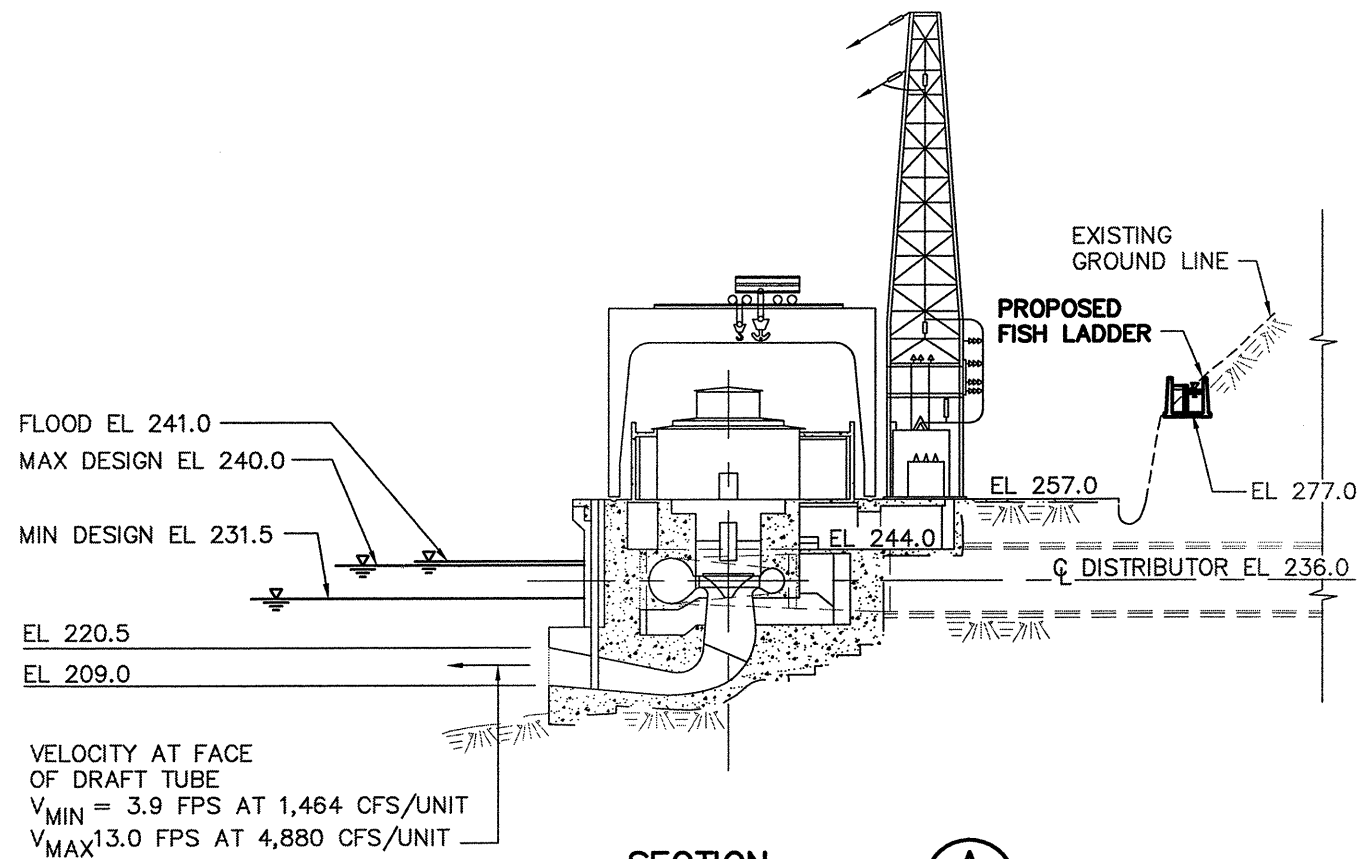

SECTION A
 APPROX STATION 5+00 YU-1.1

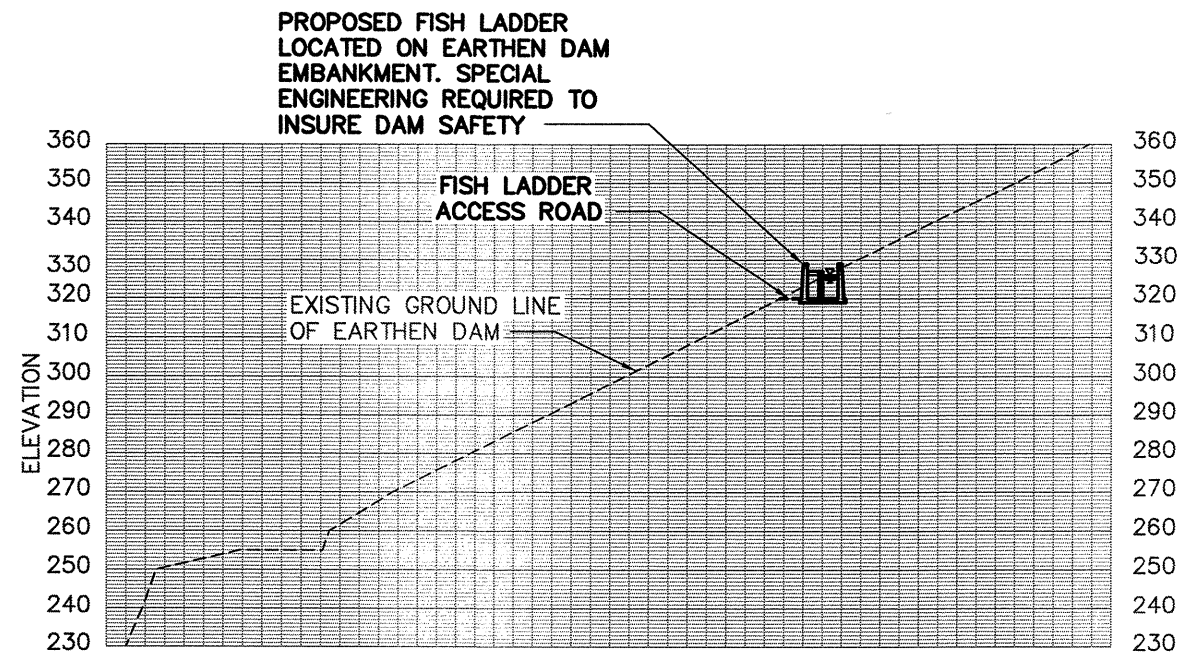

SECTION B
 APPROX STATION 10+62 YU-1.1

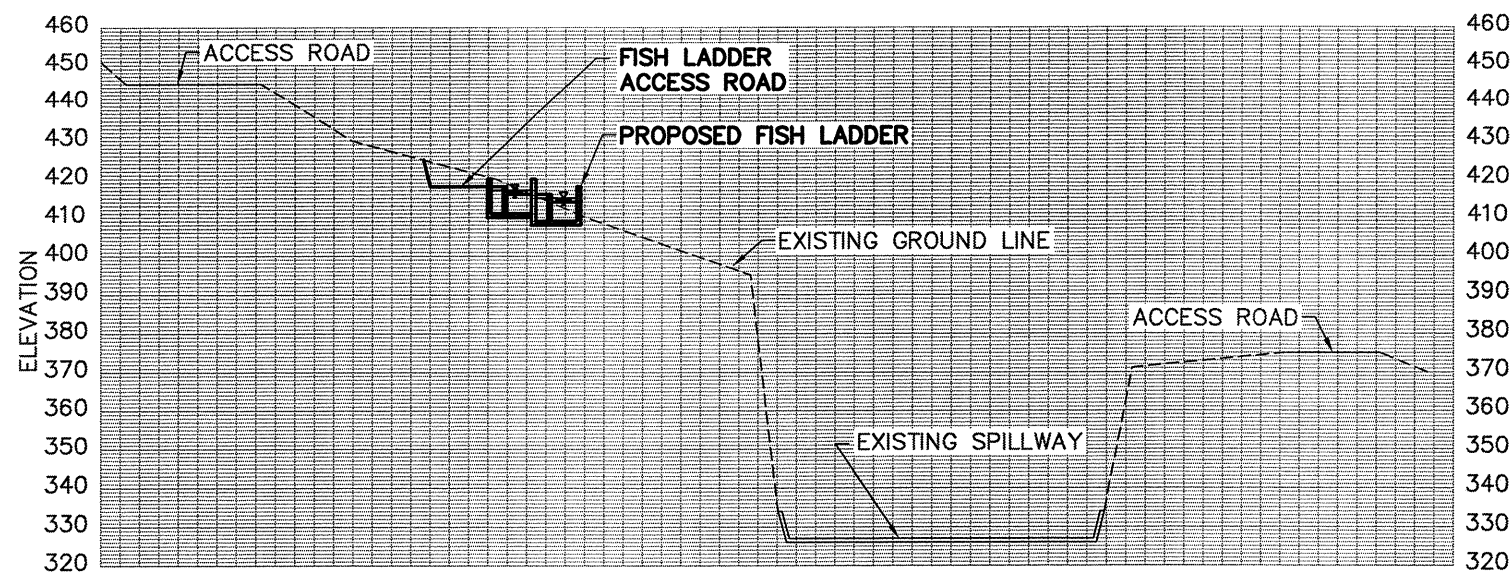

SECTION C
 APPROX STATION 20+32 YU-1.1

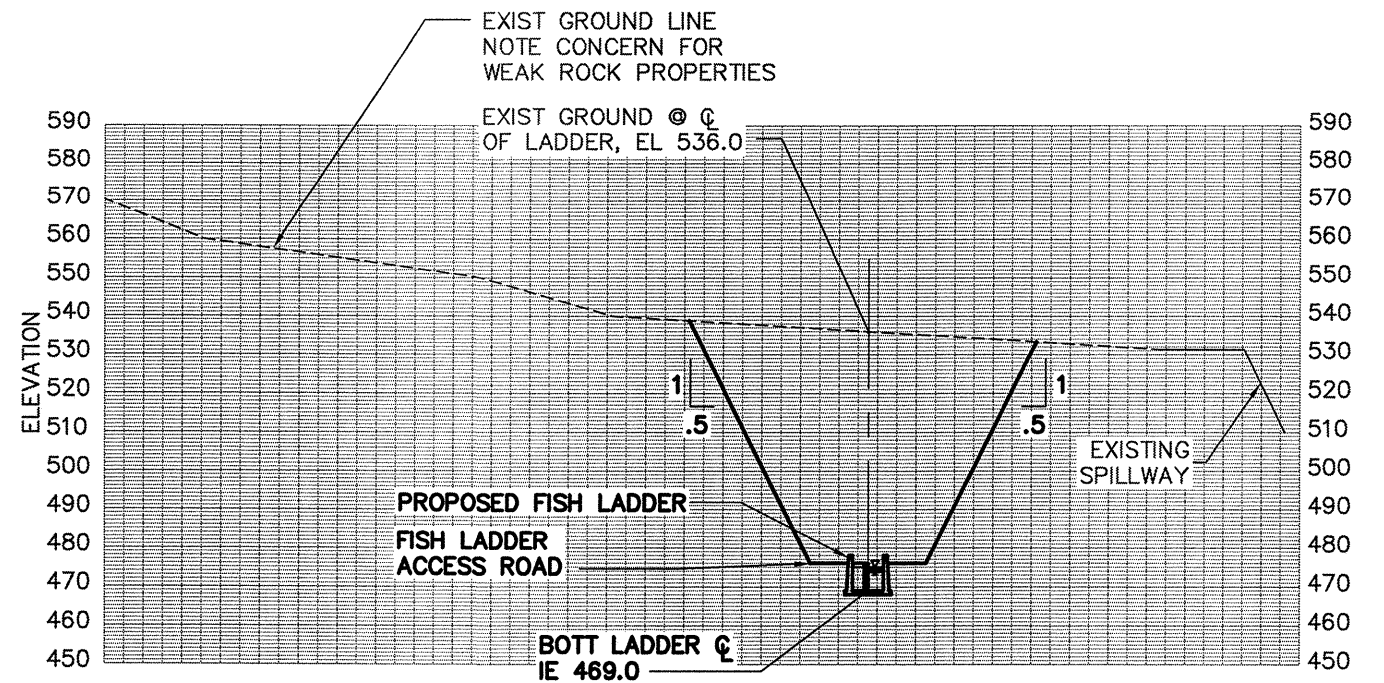

SECTION D
 APPROX STATION 26+59 YU-1.1

NOTES:

1. SECTIONS SHOWN TO ILLUSTRATE LOCATION RELATIVE TO EXIST GROUND ALL CUT LINES NOT SHOWN.
2. CUTS ASSUMED TO BE IN ROCK SECTIONS. ROCK ALONG SPILLWAY IS KNOWN TO BE UNSTABLE, ASSUME 0.5H:1.0V CUT PRIOR TO GEOTECHNICAL STUDIES.

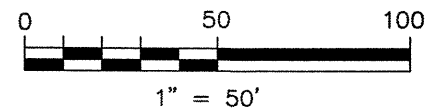

PACIFICORP LEWIS RIVER HYDRO PROJECT FISH PASSAGE STUDY FERC No 2071

YALE DAM FISH LADDER SECTIONS

Drawing **YU-1.3**

Scale: 1" = 50'
 Date: FEB, 2002
 File: O:\7262G\FPDR\YALE

MWH BELLEVUE, WASHINGTON (425) 602-4000

SPILLWAY CHANNEL MODIFICATION TO IMPROVE SURVIVAL FOR DOWNSTREAM FISH PASSAGE EXCAVATE SMOOTH 5' WIDE CHANNEL THROUGH ROCK OUTCROP

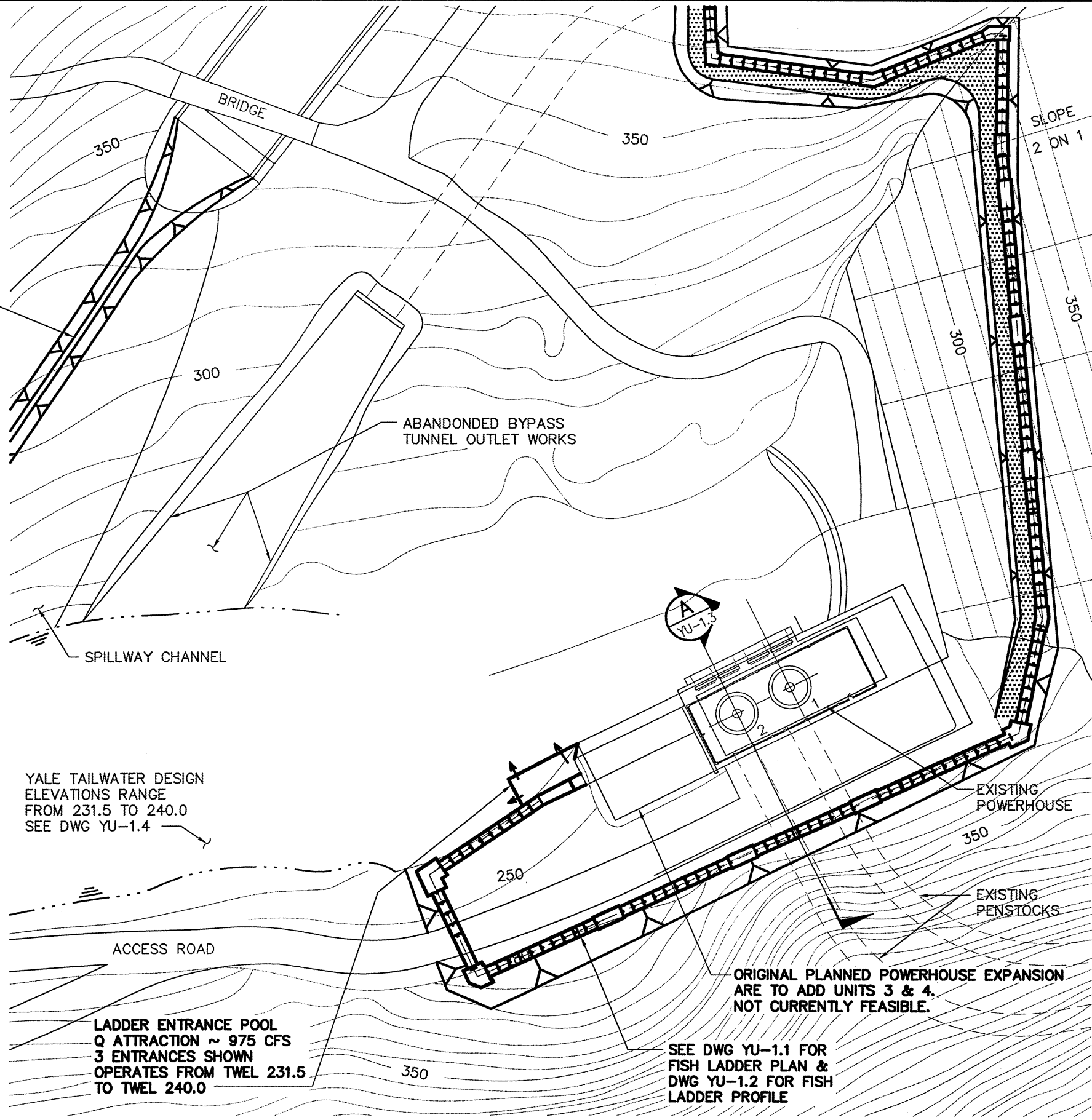

PLAN

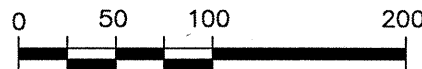

1" = 100'

PACIFICORP LEWIS RIVER HYDRO PROJECT	FISH PASSAGE STUDY FERC No 2071
YALE DAM	
FISH LADDER ENTRANCE	
ENLARGED PLAN	
Scale: AS SHOWN	Drawing: YU-1.4
Date: APR, 2002	
File: O:\7262G\FPDR\YALE	
MWH	
<small>BELLEVUE, WASHINGTON (425) 602-4000</small>	

BTaylor 10/28/02 2:14 PM

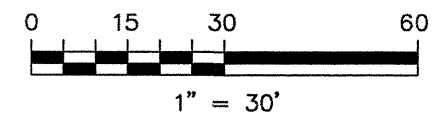
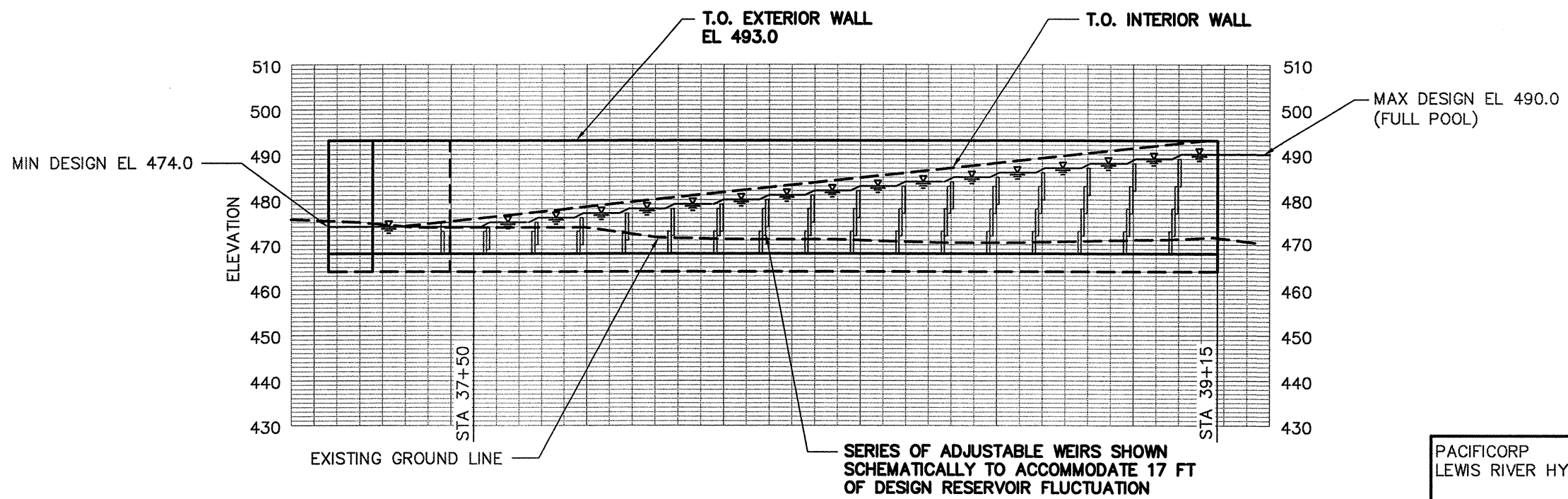
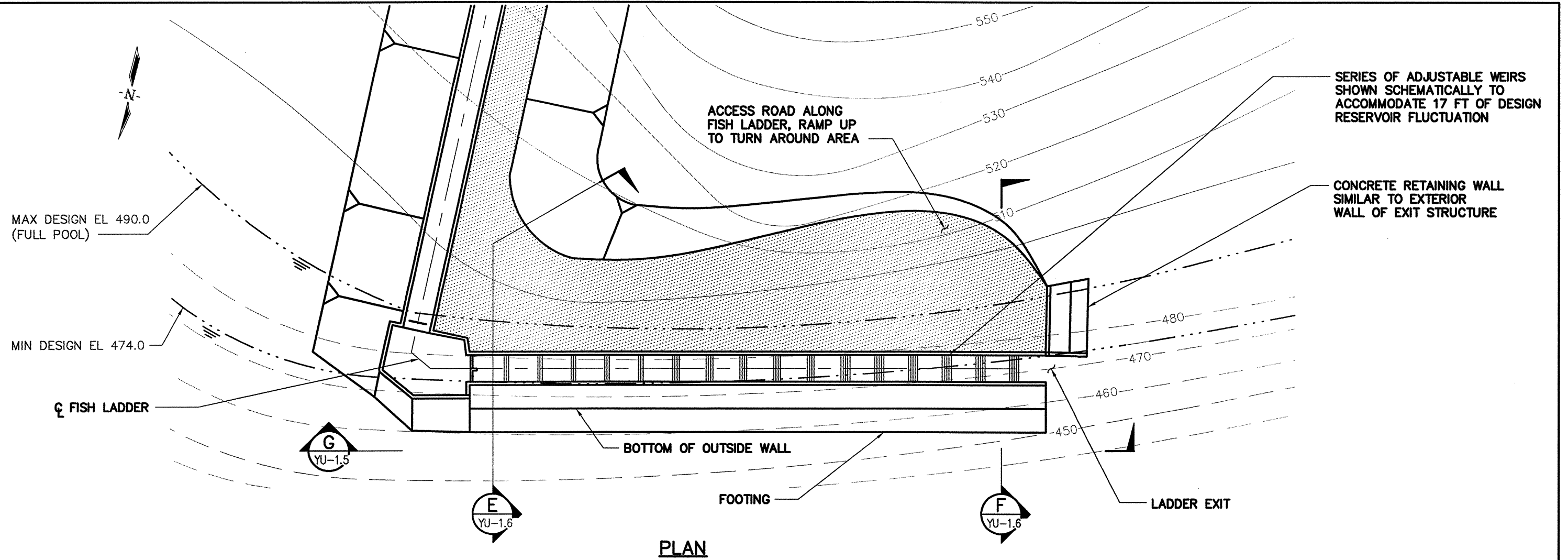

PACIFICORP FISH PASSAGE STUDY
LEWIS RIVER HYDRO PROJECT FERC No 2071

YALE DAM
FISH LADDER EXIT
PLAN & ELEVATION

Scale: 1" = 30'
Date: FEB, 2002
File: O:\7262G\FPDR\YALE Drawing YU-1.5

MWH BELLEVUE, WASHINGTON (425) 602-4000

BTaylor 10/28/02 2:15 PM

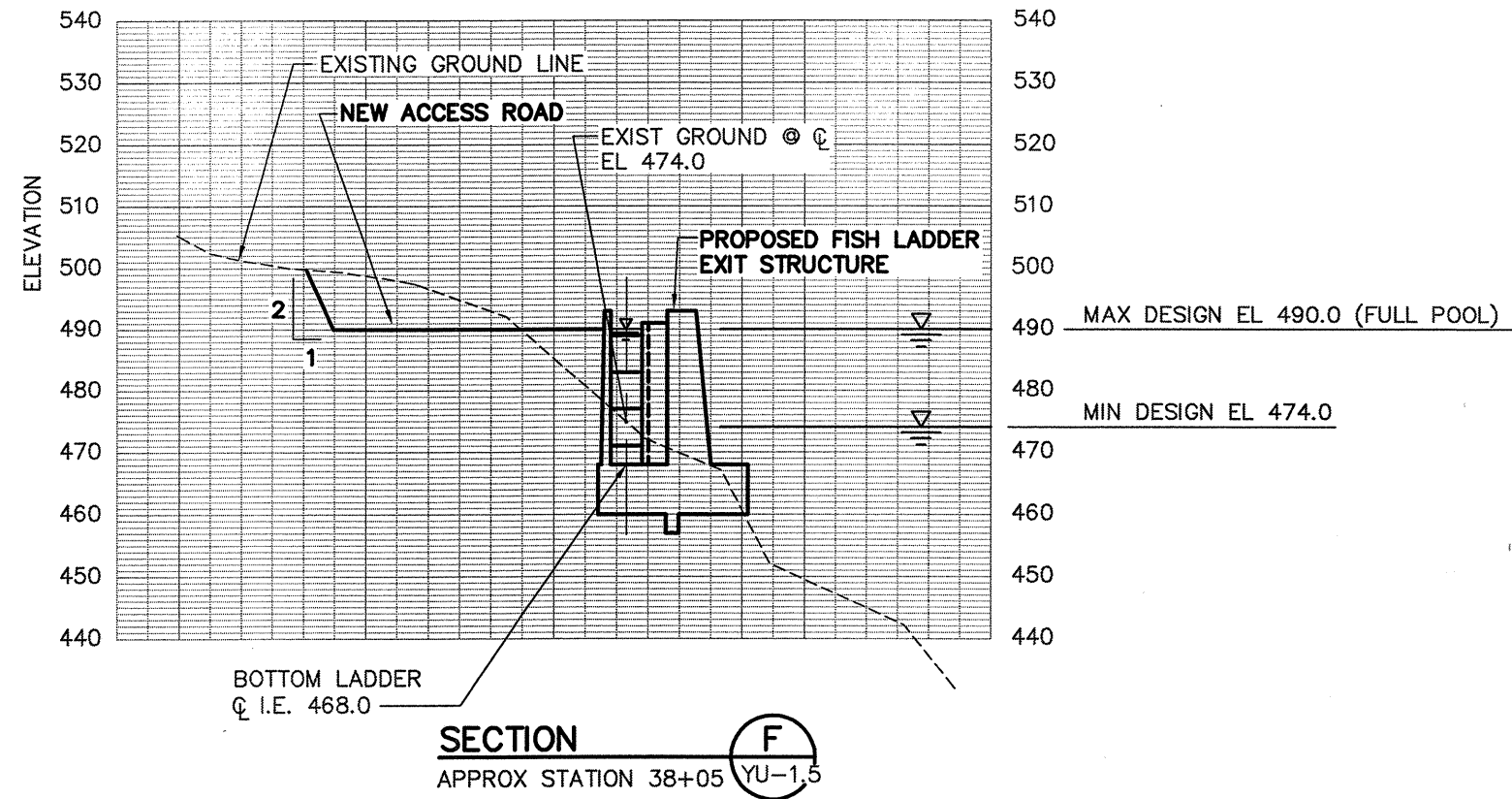
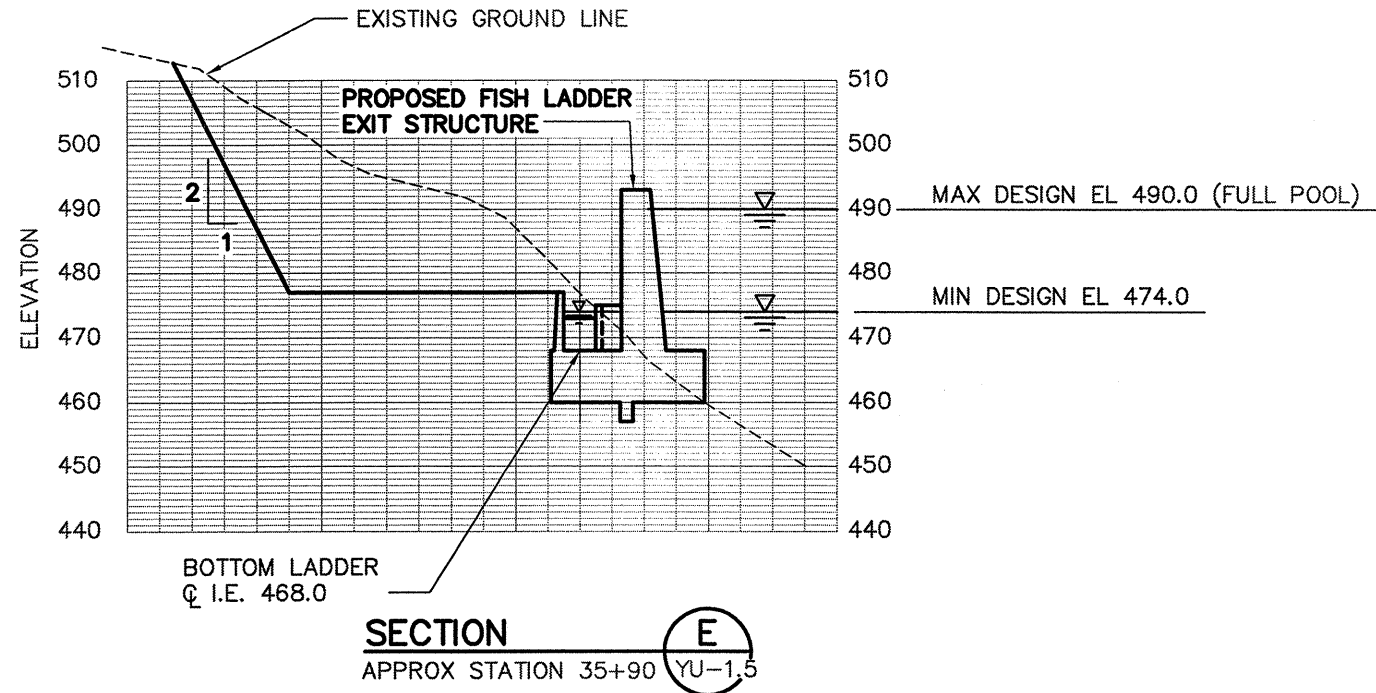

NOTE:
SECTIONS SHOWN TO SCHEMATICALLY ILLUSTRATE DESIGN REQUIREMENTS, ADDITIONAL ENGINEERING REQUIRED.

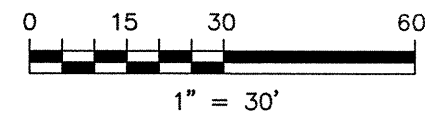

PACIFICORP LEWIS RIVER HYDRO PROJECT	FISH PASSAGE STUDY FERC No 2071
YALE DAM	
FISH LADDER EXIT	
SECTIONS	
Scale: 1" = 30' Date: FEB, 2002 File: O:\7262G\FPDR\YALE	Drawing YU-1.6
MWH	
<small>BELLEVUE, WASHINGTON (425) 602-4000</small>	

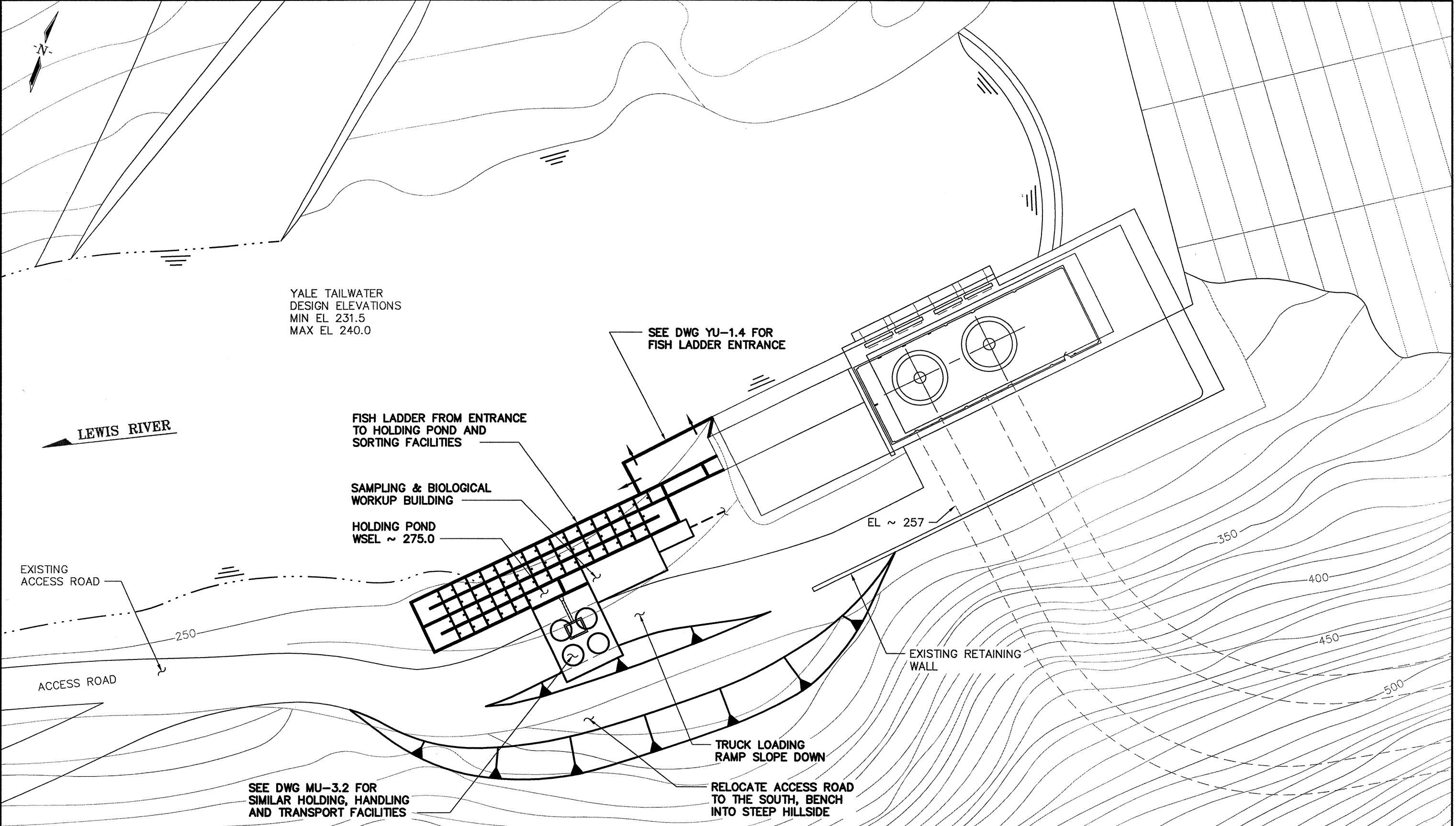

YALE TAILWATER
 DESIGN ELEVATIONS
 MIN EL 231.5
 MAX EL 240.0

SEE DWG YU-1.4 FOR
 FISH LADDER ENTRANCE

FISH LADDER FROM ENTRANCE
 TO HOLDING POND AND
 SORTING FACILITIES

SAMPLING & BIOLOGICAL
 WORKUP BUILDING

HOLDING POND
 WSEL ~ 275.0

EL ~ 257

350

400

450

500

LEWIS RIVER

EXISTING
 ACCESS ROAD

250

ACCESS ROAD

EXISTING RETAINING
 WALL

TRUCK LOADING
 RAMP
 SLOPE DOWN

SEE DWG MU-3.2 FOR
 SIMILAR HOLDING, HANDLING
 AND TRANSPORT FACILITIES

RELOCATE ACCESS ROAD
 TO THE SOUTH, BENCH
 INTO STEEP HILLSIDE

PLAN

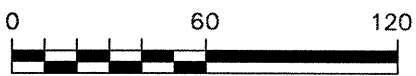

1" = 60'

PACIFICORP LEWIS RIVER HYDRO PROJECT	FISH PASSAGE STUDY FERC No 2071
YALE DAM TRAP AND HAUL PLAN	
Scale: 1" = 60' Date: FEB, 2002 File: O:\7262G\FPDR\YALE	Drawing YU-2.1
MWH	
<small>BELLEVUE, WASHINGTON (425) 602-4000</small>	

BTaylor 10/28/02 2:17 PM

MATCHLINE
FOR CONTINUATION
SEE DWG SU-1.2

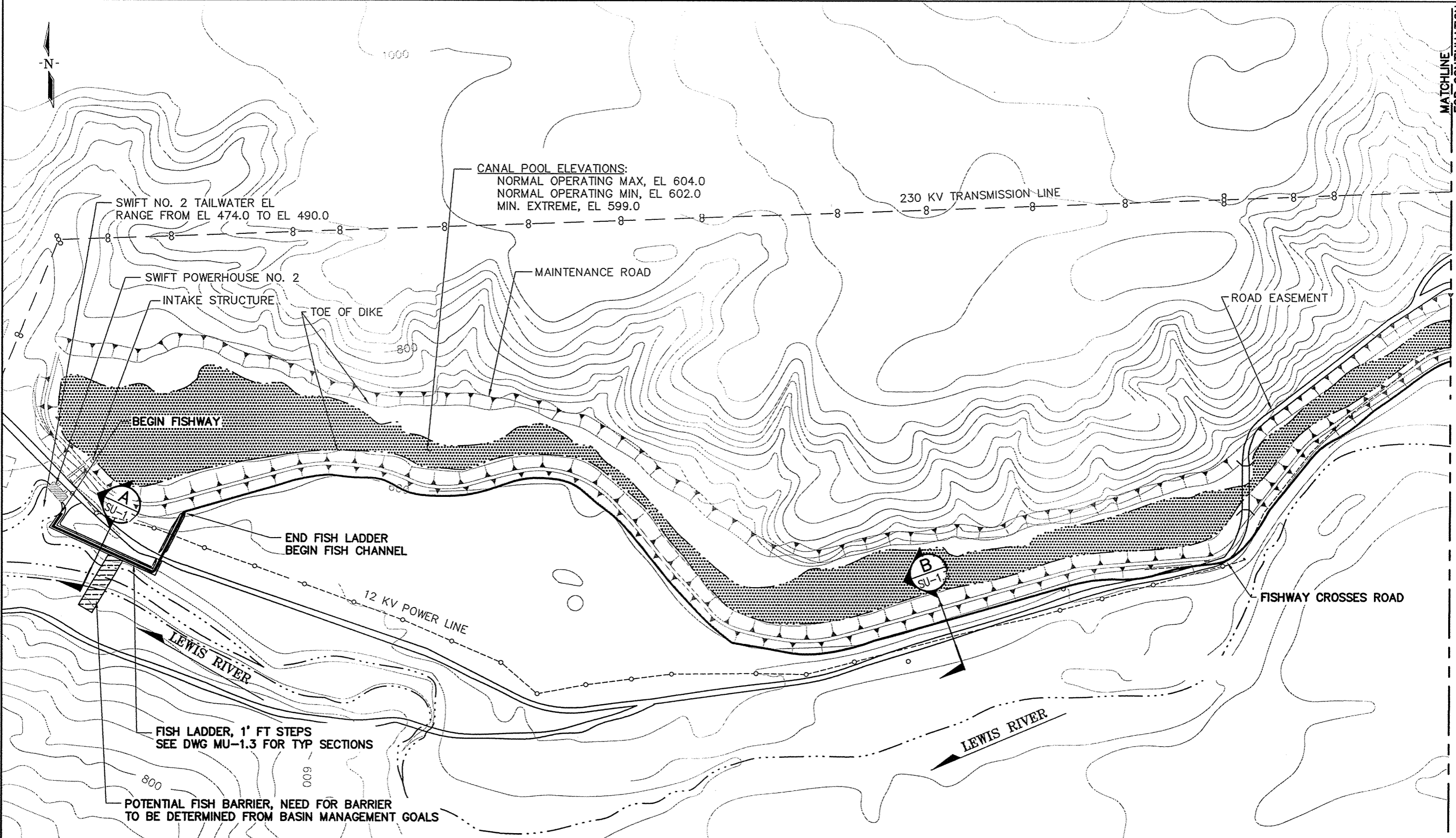
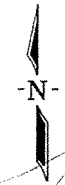

CANAL POOL ELEVATIONS:
NORMAL OPERATING MAX, EL 604.0
NORMAL OPERATING MIN, EL 602.0
MIN. EXTREME, EL 599.0

SWIFT NO. 2 TAILWATER EL
RANGE FROM EL 474.0 TO EL 490.0

230 KV TRANSMISSION LINE

SWIFT POWERHOUSE NO. 2
INTAKE STRUCTURE

MAINTENANCE ROAD

ROAD EASEMENT

BEGIN FISHWAY

END FISH LADDER
BEGIN FISH CHANNEL

FISHWAY CROSSES ROAD

12 KV POWER LINE

LEWIS RIVER

LEWIS RIVER

FISH LADDER, 1' FT STEPS
SEE DWG MU-1.3 FOR TYP SECTIONS

POTENTIAL FISH BARRIER, NEED FOR BARRIER
TO BE DETERMINED FROM BASIN MANAGEMENT GOALS

PLAN

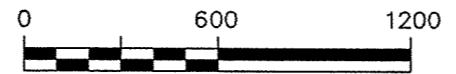

1" = 600'

PACIFICORP / COWLITZ PUD FISH PASSAGE STUDY
LEWIS RIVER HYDRO PROJECT FERC No's 2111 & 2213

**SWIFT NO. 2
FISH LADDER
PLAN**

Scale: 1" = 600'
Date: FEB, 2002
File: O:\7262G\FPDR\SCO

Drawing **SU-1.1**

MWH
BELLEVUE, WASHINGTON
(425) 602-4000

BTaylor 10/29/02 6:08 PM

MATCHLINE
FOR CONTINUATION
SEE DWG SU-1.1

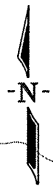

FISH LADDER EXIT, SEE DWG SU-1.4
FOR ELEVATION

MAX DESIGN EL 1000.0 (FULL POOL)
MIN DESIGN EL 960.0
RECORD LOW (1967) POOL EL 884.0

FISH LADDER SEE DWG MU-1.3
FOR TYP SECTIONS

EL 960.0 END FISH
LADDER BEGIN FISHWAY

LADDER EXIT STRUCTURE
DESIGN MUST ACCOMODATE
RESERVOIR FLUCTUATION
FROM EL 1000.0 TO 960.0

230 KV TRANSMISSION LINE

SWIFT NO 1
FISH LADDER

CHECK STRUCTURE
WASTEWAY

SWITCHYARD

12 KV POWER LINE

SWIFT
RESERVOIR

FISH LADDER CROSSES
POWER CHANNEL

LEWIS RIVER

SPILLWAY

POWER
TUNNEL

SWIFT DAM

SWIFT POWERHOUSE NO. 1

TAILRACE ELEVATIONS:
1 UNIT MAX. OUTPUT, EL 602.0
2 UNIT MAX. OUTPUT, EL 603.0
3 UNIT MAX. OUTPUT, EL 604.0

FISH LADDER ENTRANCE TO BE LOCATED NEAR UPSTREAM END
OF BYPASS REACH NEAR SPILLWAY PLUNGE POOL. ENTRANCE
WOULD BE DESIGNED IN CONJUNCTION WITH SOURCE WATER
RELEASE FACILITIES FOR BYPASS REACH. PROJECT ENTRANCE
FROM SWIFT NO. 1 SPILL.

PLAN

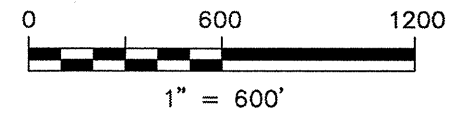

PACIFICORP / COWLITZ PUD FISH PASSAGE STUDY
LEWIS RIVER HYDRO PROJECT FERC No's 2111 & 2213

**SWIFT NO. 1
FISH LADDER
PLAN**

Scale: 1" = 600'
Date: FEB, 2002
File: O:\7262G\FPDR\SCO Drawing **SU-1.2**

MWH
BELLEVUE, WASHINGTON
(425) 602-4000

NHupprich 10/28/02 3:00 PM

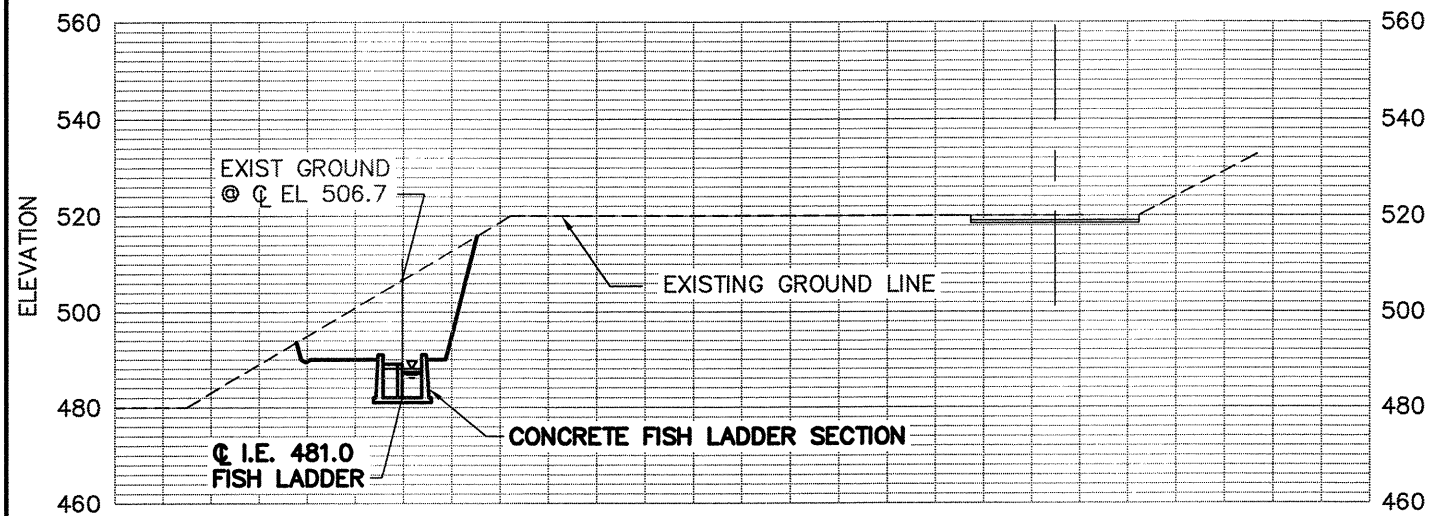

SECTION **A**
SU-1,1

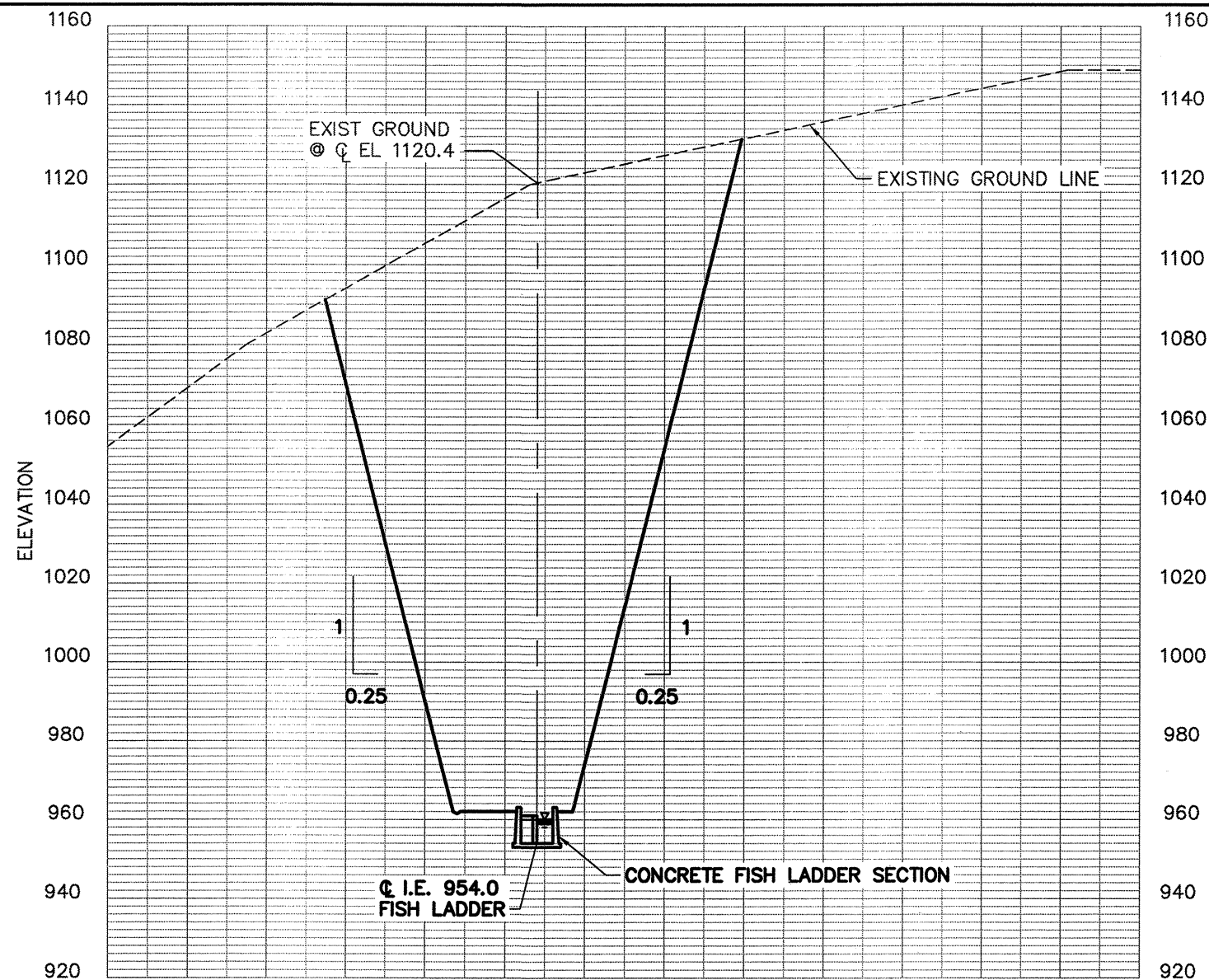

SECTION **C**
SU-1,2

NOTE: TUNNEL SECTION MAY BE MORE ECONOMICAL THAN OPEN CUT.

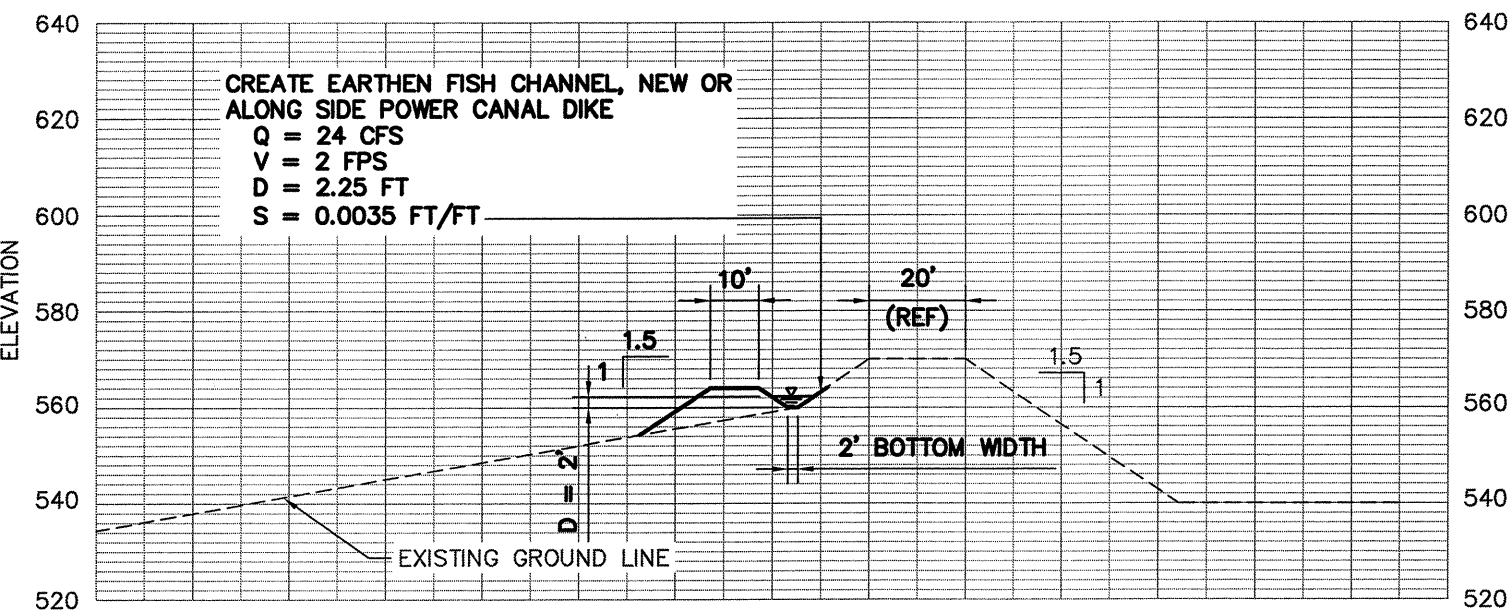
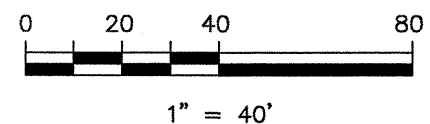

SECTION **B**
SU-1,1

PACIFICORP FISH PASSAGE STUDY
LEWIS RIVER HYDRO PROJECT FERC No's 2111 & 2213

**SWIFT NO. 1
FISH LADDER
SECTIONS**

SU-1.3

Scale: 1" = 40'
Date: FEB, 2002
File: O:\72626\FPDR\SCO

MWH Drawing
BELLEVUE, WASHINGTON
(425) 602-4000

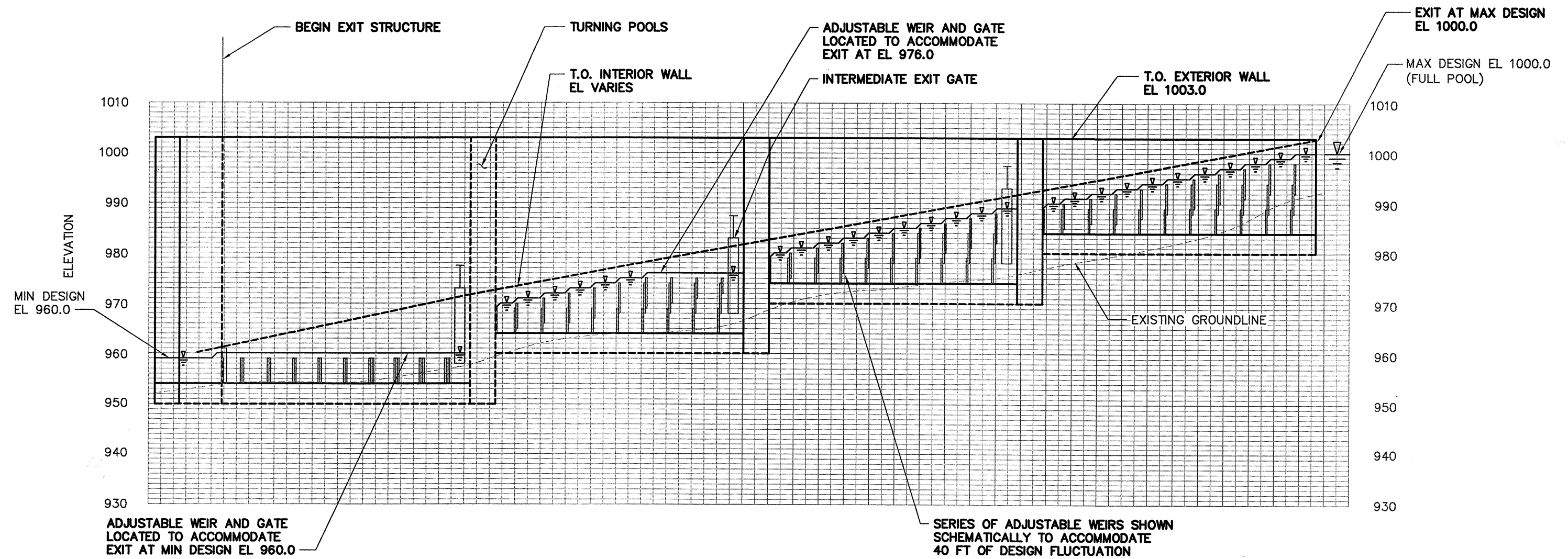

EXIT STRUCTURE ELEVATION

NOTE:

DESIGN SHOWN IS INTENDED TO ILLUSTRATE SIZE, DESIGN REQUIREMENTS AND GENERAL LOCATION TO ACCOMMODATE A 40 FT RESERVOIR FLUCTUATION WITH A SIMPLE, MULTIPLE WEIR AND GATE CONFIGURATION.

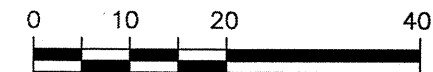

VERTICAL
1" = 20'

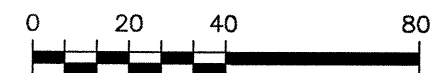

HORIZONTAL
1" = 40'

PACIFICORP LEWIS RIVER HYDRO PROJECT	FISH PASSAGE STUDY FERC No 2071
SWIFT NO. 1	
FISH LADDER EXIT	
ELEVATION	
Scale: AS SHOWN Date: FEB, 2002 File: O:\7262G\FPDR\SCO	Drawing SU-1.4
MWH	
<small>BELLEVUE, WASHINGTON (425) 602-4000</small>	

Tab B

Downstream Passage Facility Drawings

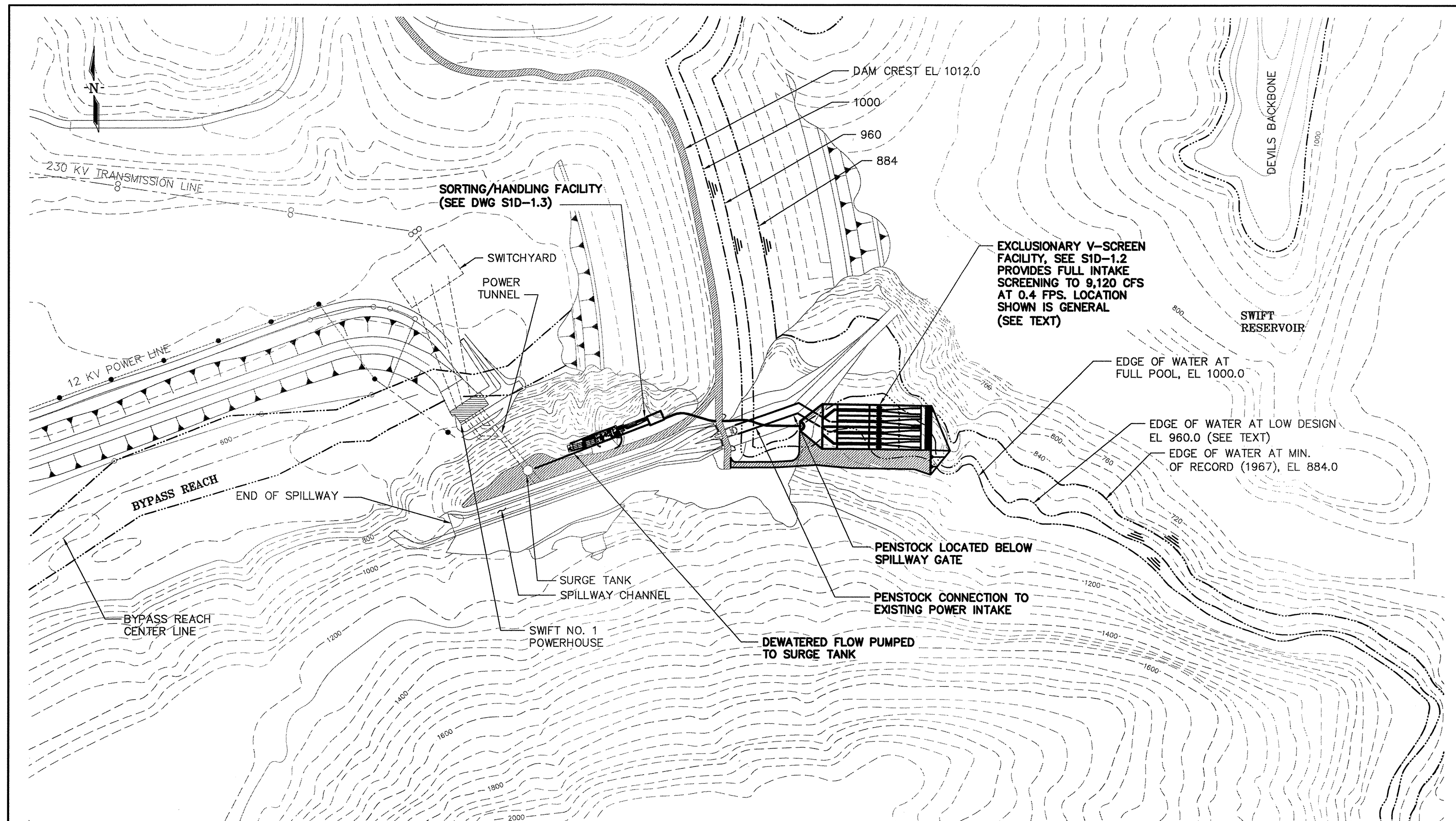

POWERHOUSE	Qmax (CFS)	Qmin (CFS)	REQUIRED CRITERIA SCREEN AREA (SF)
UNIT 11	3,040	912	7600
UNIT 12	3,040	912	7600
UNIT 13	3,040	912	7600
Q TOTAL	9,120	2,736	22,800
SPELLWAY	120,000	-	-
50x51 GATE	60,000	-	-
50x51 GATE	60,000	-	-

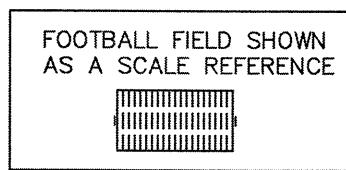
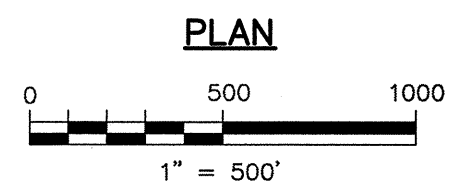

PACIFICORP FISH PASSAGE STUDY
 LEWIS RIVER HYDRO PROJECT FERC No 2111

**SWIFT NO. 1 DOWNSTREAM
 0.4 FPS V-SCREEN
 PLAN**

Scale: 1" = 500'
 Date: FEB, 2002
 File: O:\7262G\FPDR\SWIFTN01 Drawing

SID-1.1

MWH
 BELLEVUE, WASHINGTON
 (425) 602-4000

N:\hp\prich 10/28/02 3:07 PM

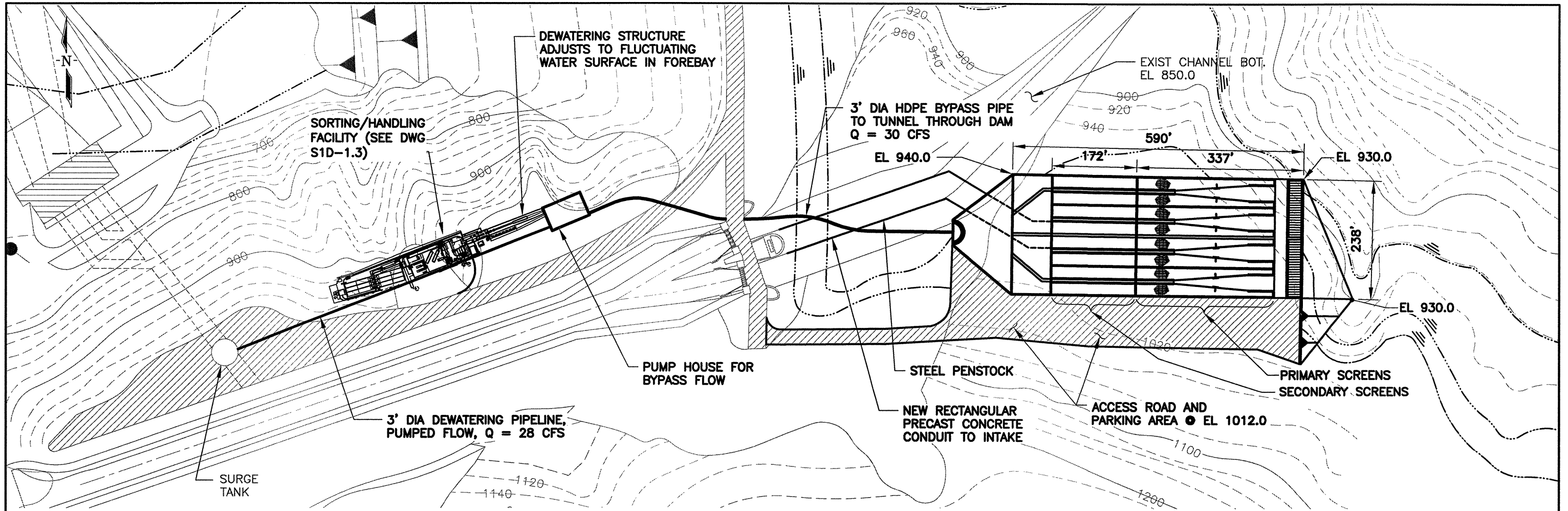

PLAN

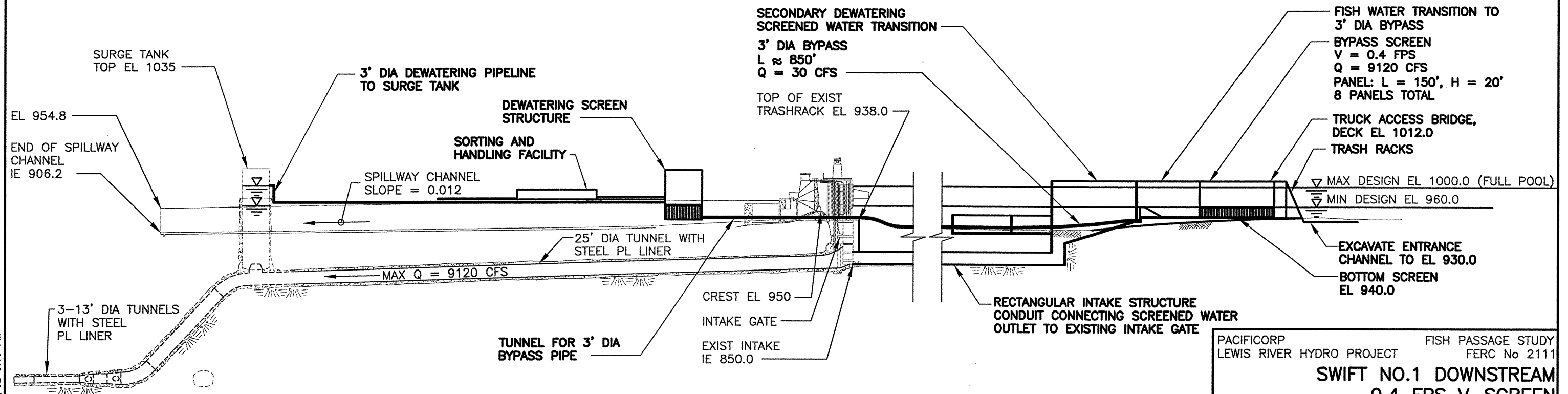

ELEVATION

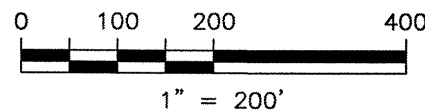

PACIFICORP FISH PASSAGE STUDY
LEWIS RIVER HYDRO PROJECT FERC No 2111

**SWIFT NO.1 DOWNSTREAM
0.4 FPS V-SCREEN
PLAN AND ELEVATION**

Scale: 1" = 200'
Date: FEB, 2002
File: O:\7262G\FPDR\SWIFTN01 Drawing

S1D-1.2

MWH

BELLEVUE, WASHINGTON
(425) 602-4000

NHuppich 10/28/02 3:10 PM

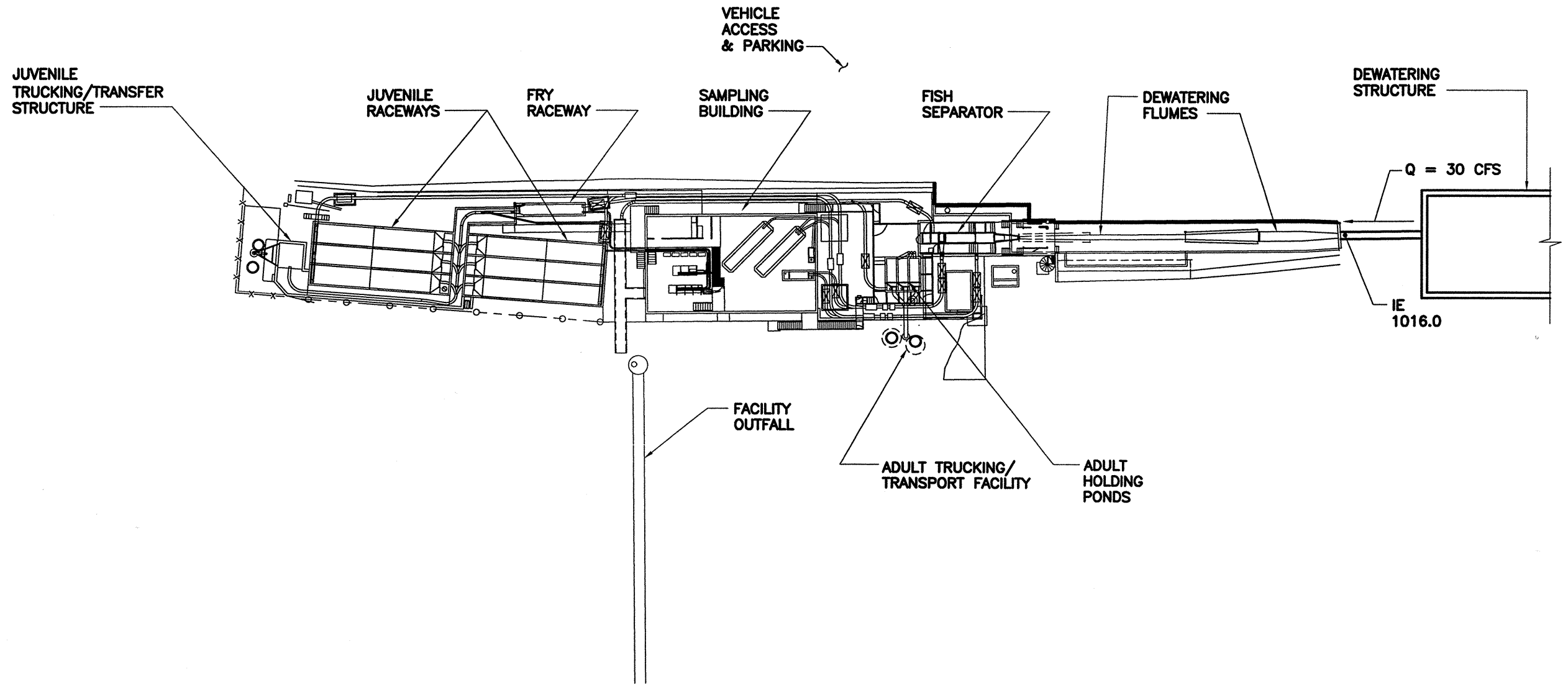
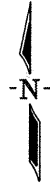

NOTE:
COMPONENTS SHOWN SCHEMATICALLY BASED
ON COWLITZ FALLS FACILITY.

PLAN

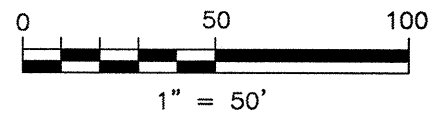

NHuppich 10/28/02 3:13 PM

PACIFICORP LEWIS RIVER HYDRO PROJECT	FISH PASSAGE STUDY FERC No 2111
SWIFT NO. 1 DOWNSTREAM SORTING & HANDLING FACILITY	
PLAN	
Scale: 1" = 50'	
Date: FEB, 2002	
File: O:\7262G\FPDR\SWIFTN01	DRAWING
S1D-1.3	
MWH	
<small>BELLEVUE, WASHINGTON (425) 602-4000</small>	

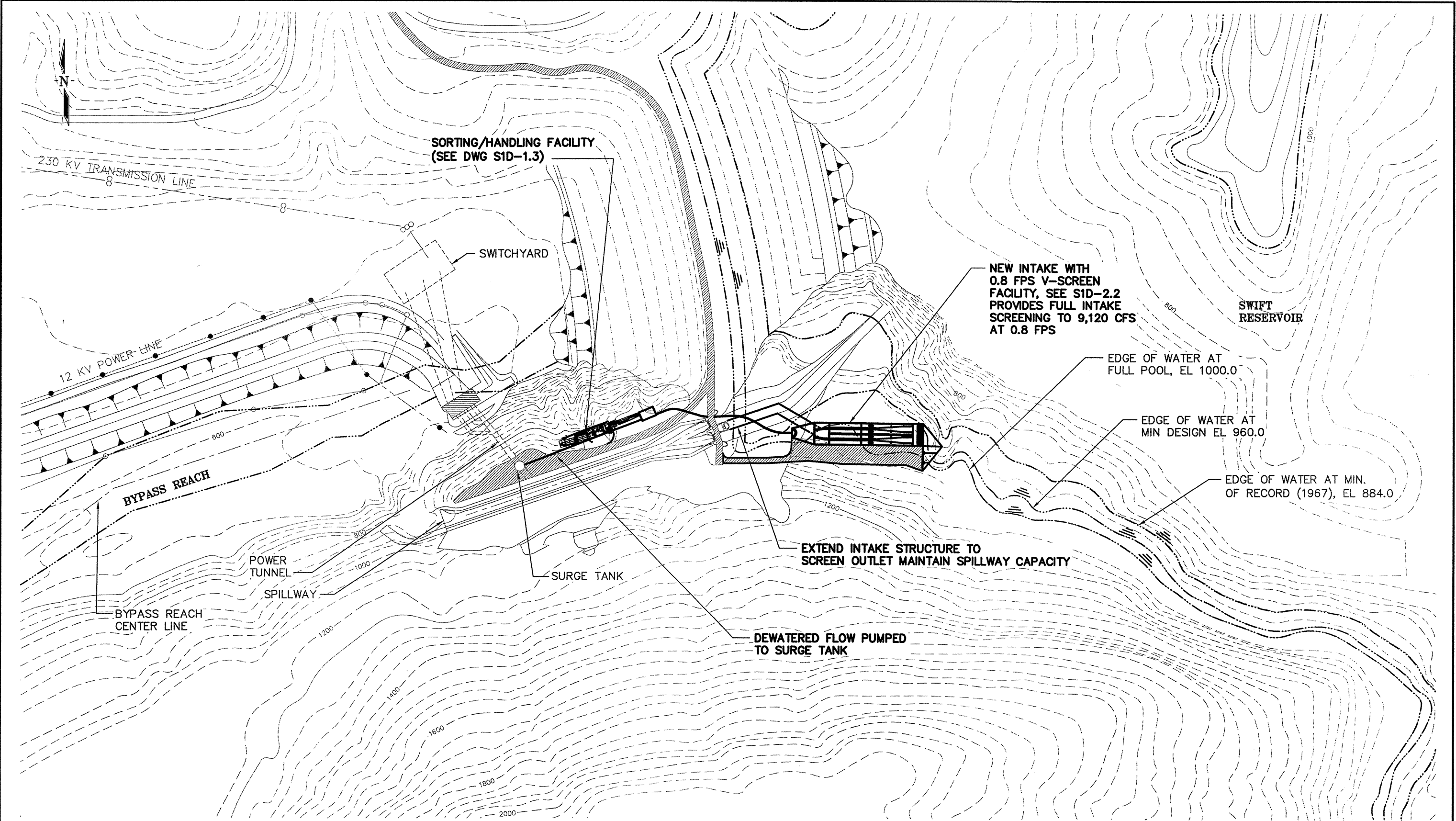

POWERHOUSE	Qmax (CFS)	Qmin (CFS)	REQUIRED CRITERIA SCREEN AREA (SF)
UNIT 11	3,040	912	7600
UNIT 12	3,040	912	7600
UNIT 13	3,040	912	7600
Q TOTAL	9,120	2,736	22,800
SPILLWAY	120,000	-	-
50x51 GATE	60,000	-	-
50x51 GATE	60,000	-	-

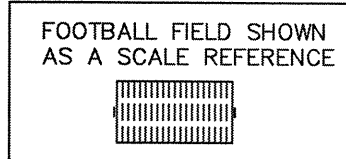
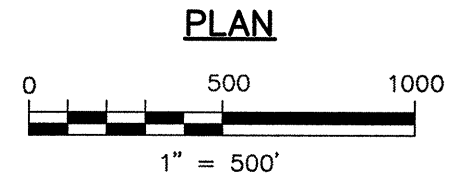

PACIFICORP FISH PASSAGE STUDY
 LEWIS RIVER HYDRO PROJECT FERC No 2111

**SWIFT NO. 1 DOWNSTREAM
 0.8 FPS V-SCREEN
 PLAN**

Scale: 1" = 500'
 Date: FEB, 2002
 File: O:\72626\FPDR\SWIFTN01 Drawing

S1D-2.1

MWH BELLEVUE, WASHINGTON (425) 602-4000

N:\hp\prich 10/28/02 3:15 PM

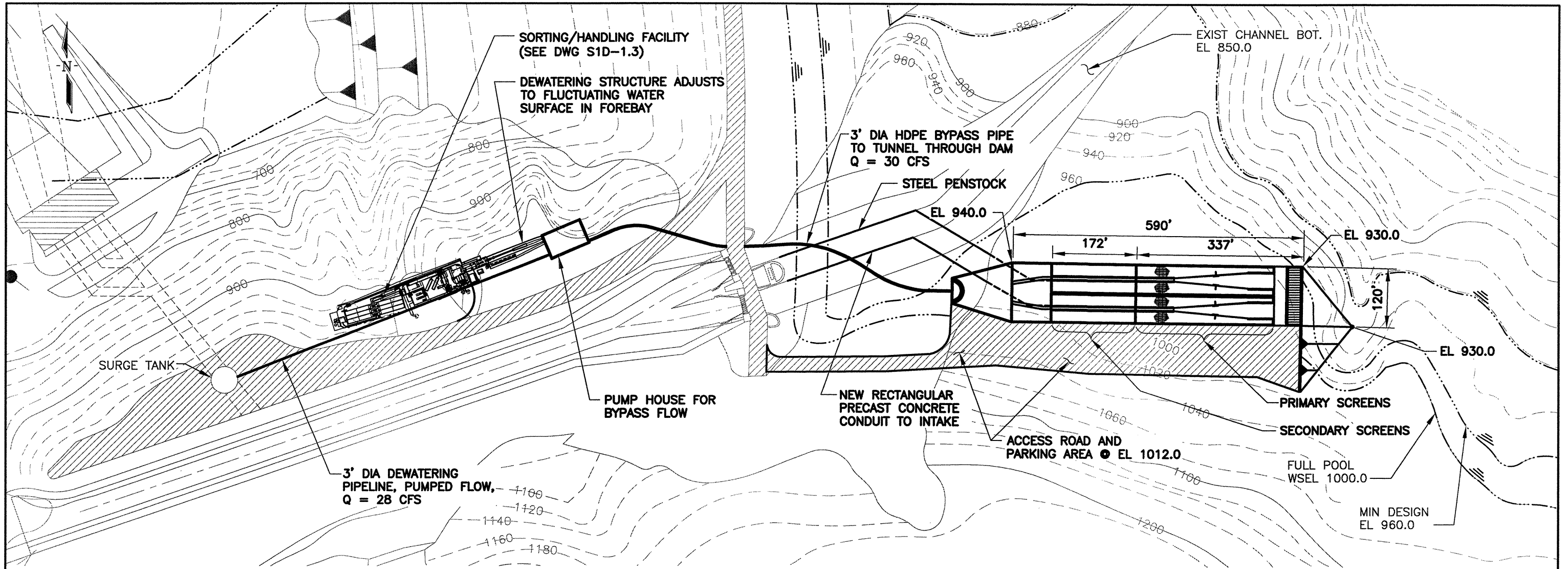

PLAN

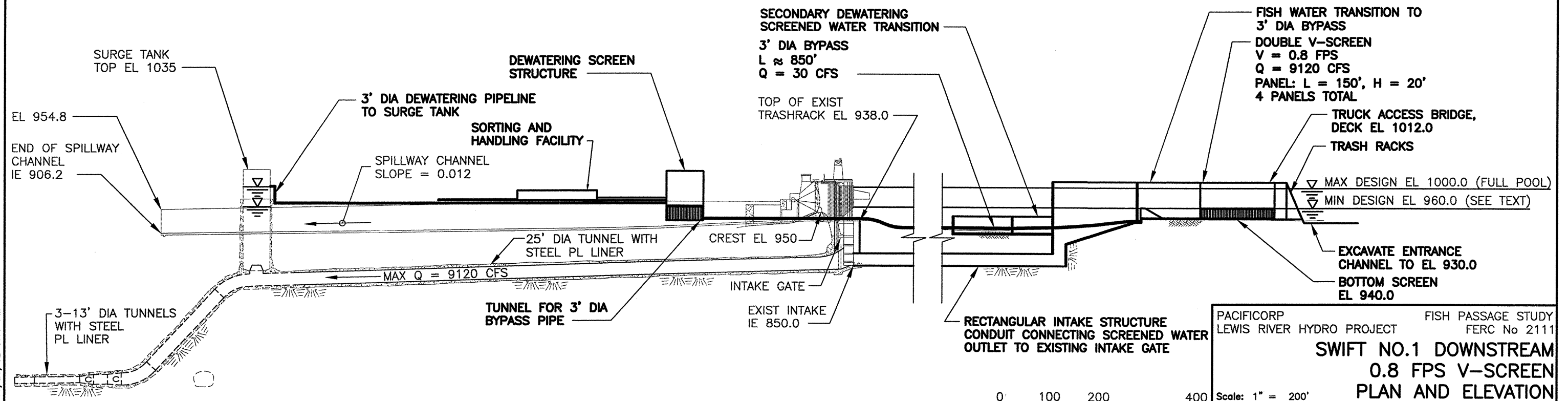

ELEVATION

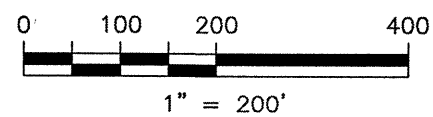

PACIFICORP LEWIS RIVER HYDRO PROJECT FISH PASSAGE STUDY FERC No 2111

SWIFT NO.1 DOWNSTREAM 0.8 FPS V-SCREEN PLAN AND ELEVATION

Scale: 1" = 200'
 Date: FEB, 2002
 File: O:\7262G\FPDR\SWIFTN01 Drawing S1D-2.2

MWH BELLEVUE, WASHINGTON (425) 602-4000

NHupprieh 10/28/02 3:19 PM

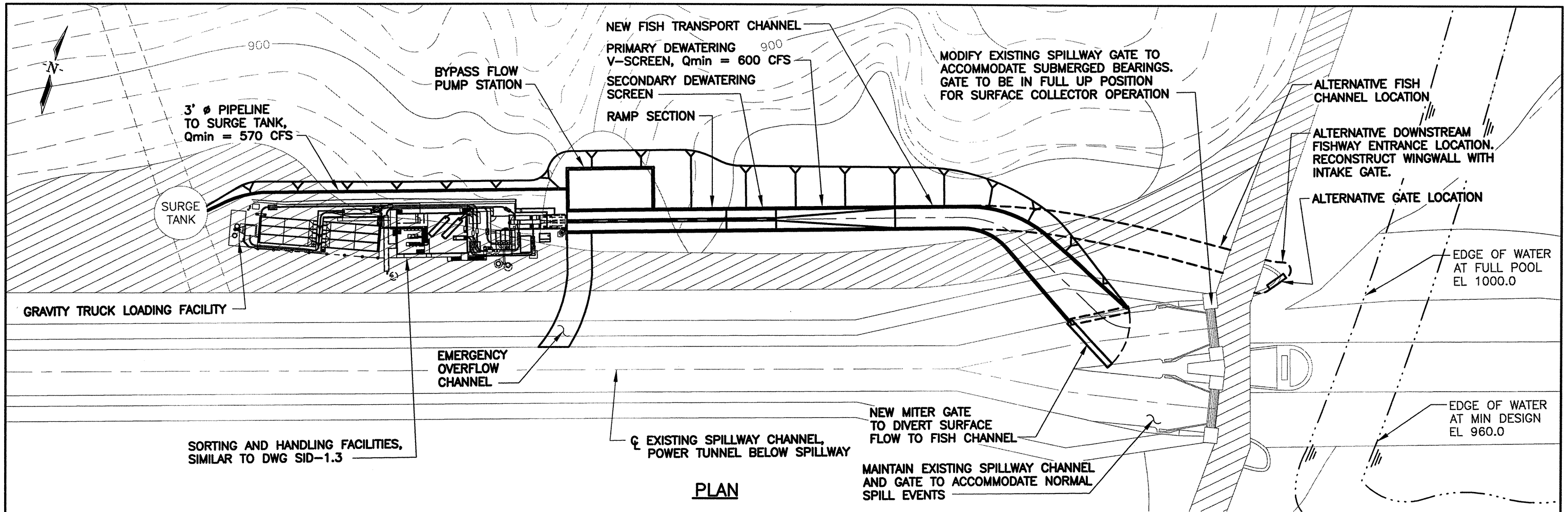

PLAN

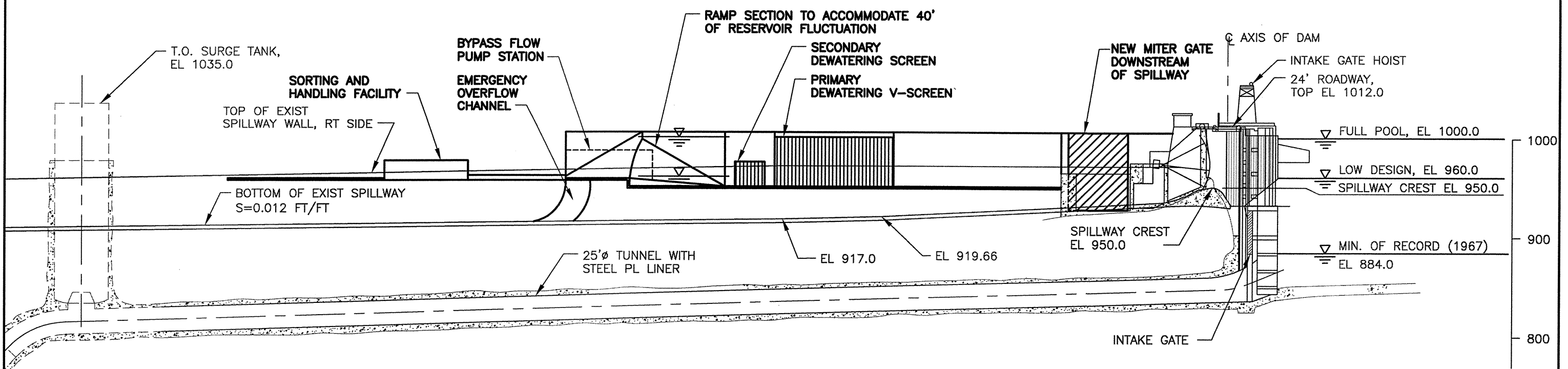

PROJECTED PROFILE THROUGH FISH BYPASS AND EXISTING SPILLWAY/POWER TUNNEL

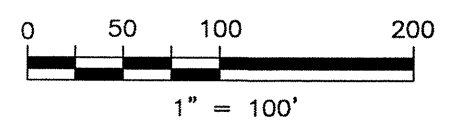

PACIFICORP FISH PASSAGE STUDY
 LEWIS RIVER HYDRO PROJECT FERC No 2111
SWIFT NO.1 DOWNSTREAM SURFACE COLLECTOR ALT 1
PLAN AND ELEVATION
 Scale: 1" = 100'
 Date: FEB, 2002
 File: O:\7262G\FPDR\SWIFTNO1 Drawing
S1D-3.1
MWH
 BELLEVUE, WASHINGTON (425) 802-4000

N:\puprich 10/28/02 3:21 PM

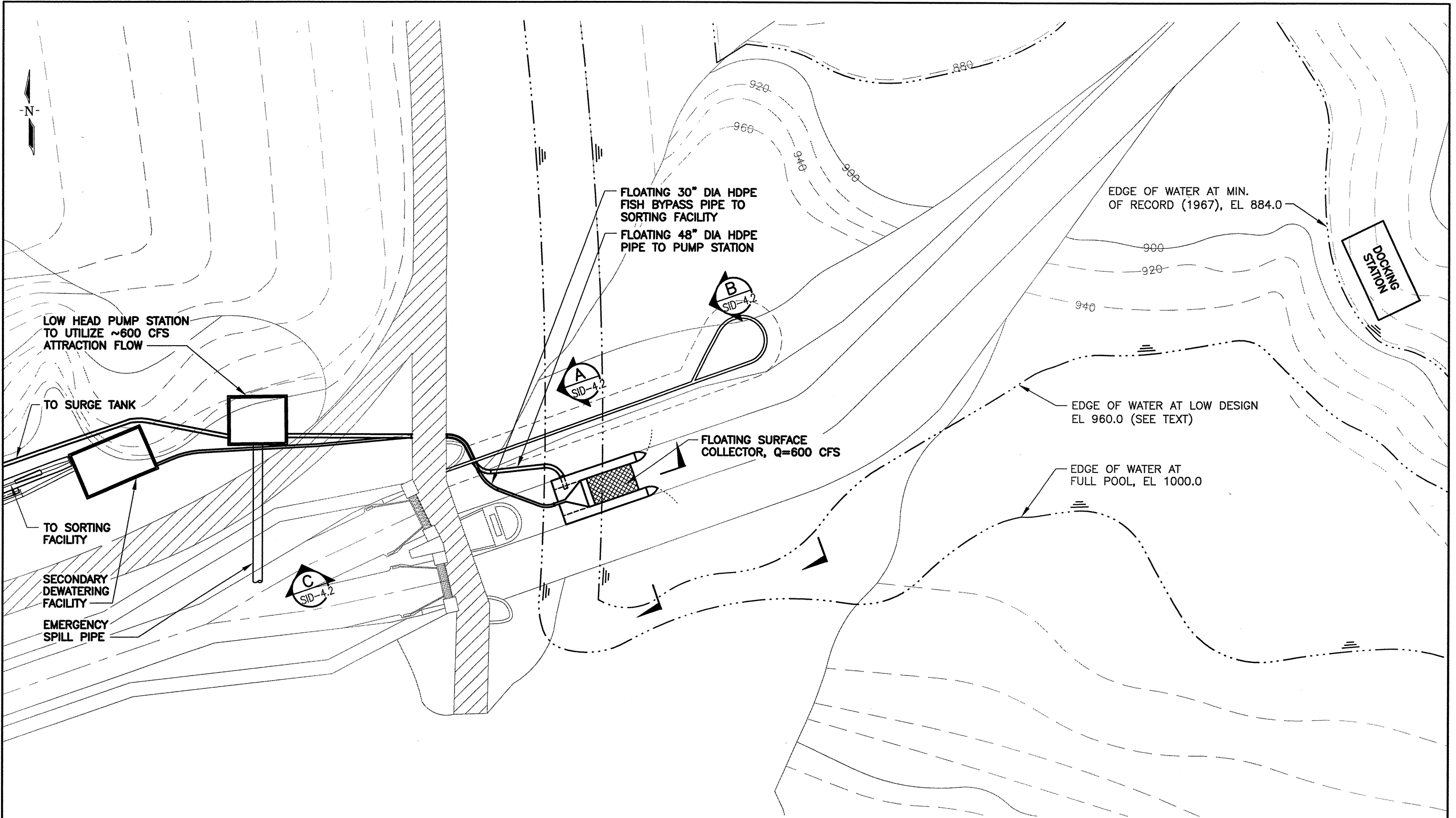

PLAN

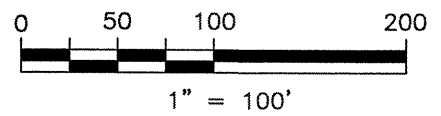

PACIFICORP LEWIS RIVER HYDRO PROJECT	FISH PASSAGE STUDY FERC No 2111
SWIFT NO.1 DOWNSTREAM SURFACE COLLECTOR ALT 2	
PLAN	
Scale: 1" = 100'	S1D-4.1
Date: APR, 2002	
File: O:\7262G\FPDR\SWIFTNO1	
MWH	
BELLEVUE, WASHINGTON (425) 802-4000	

NHupprich 10/28/02 3:22 PM

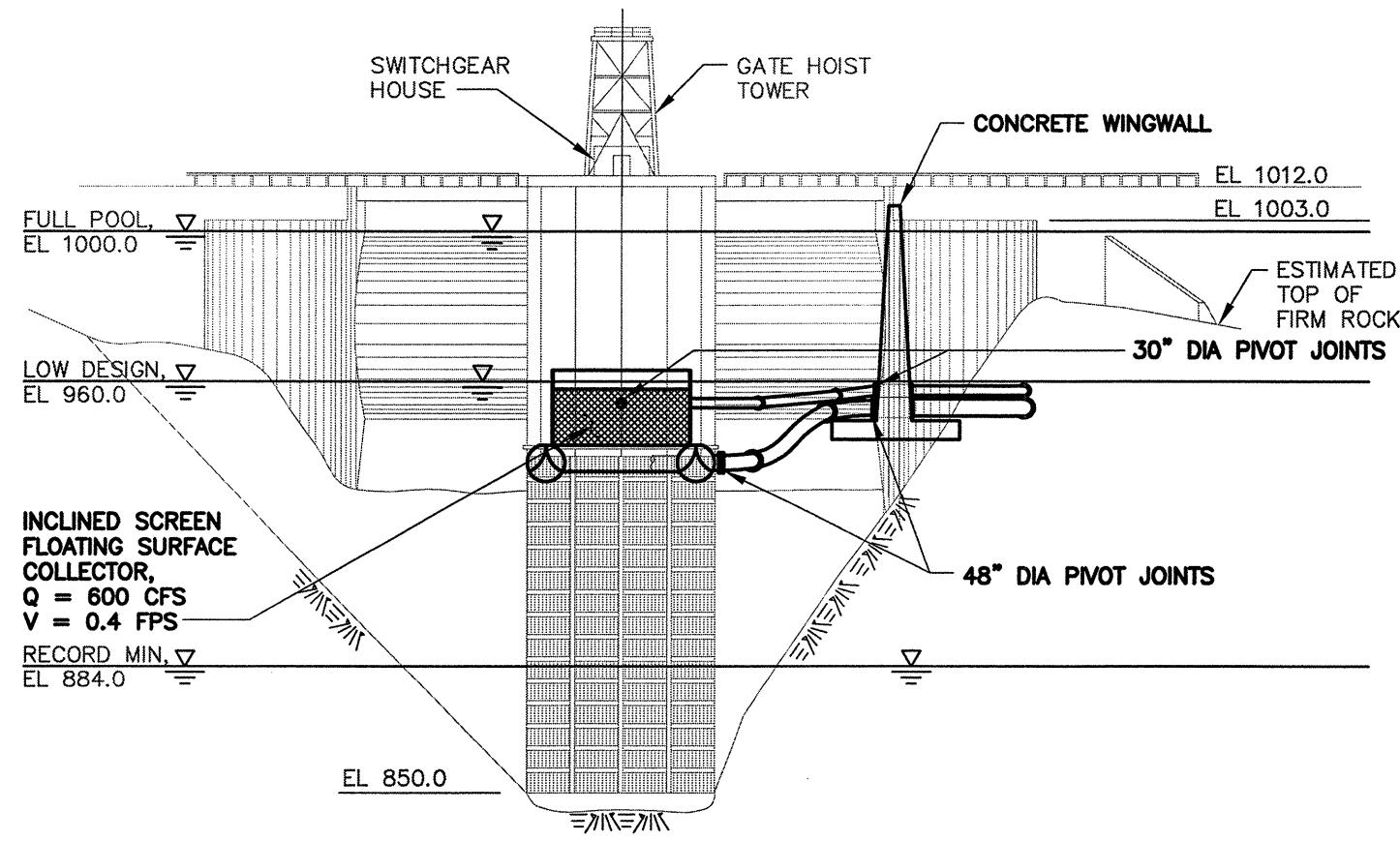

SECTION A
SID-4.1

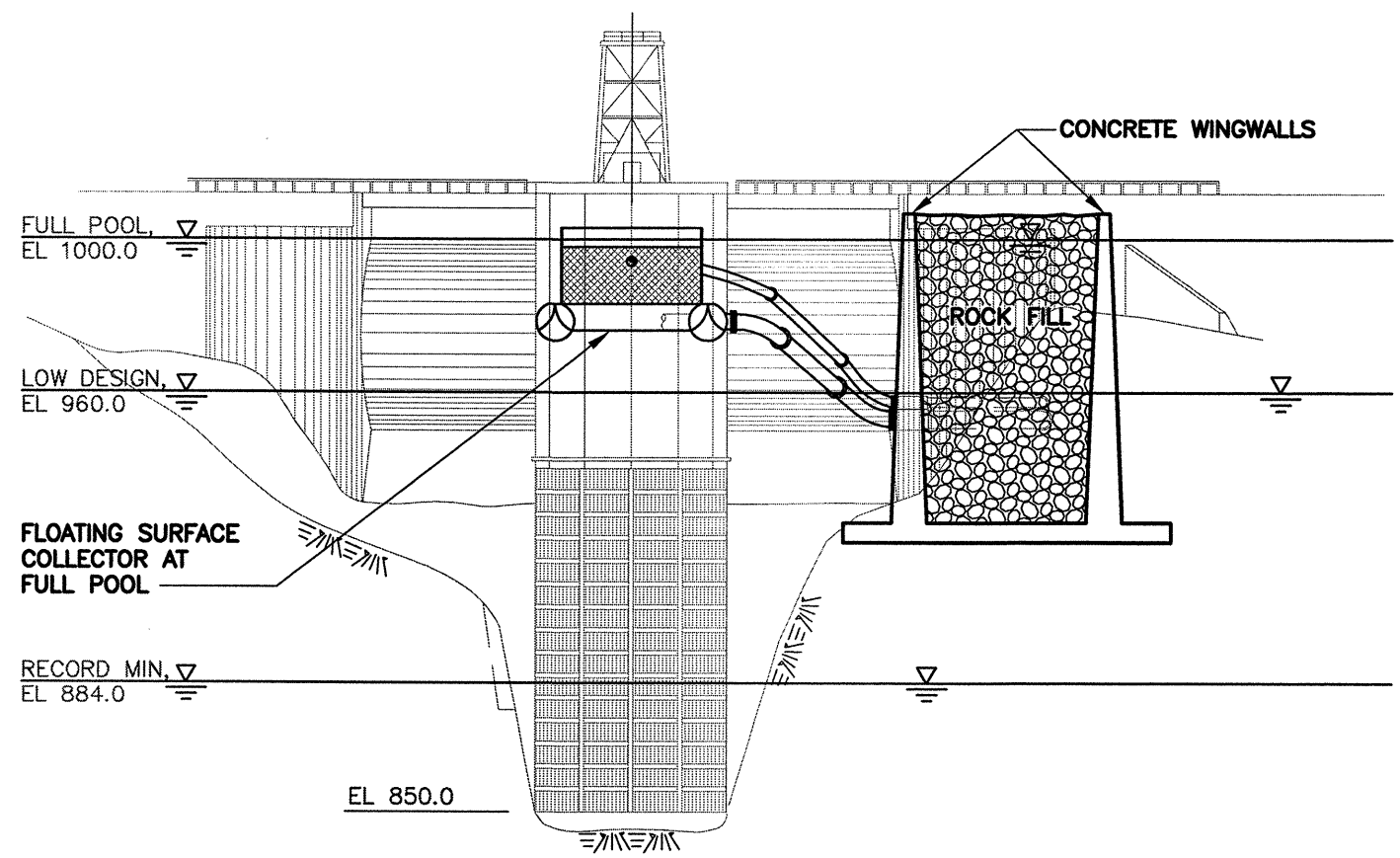

SECTION B
SID-4.1

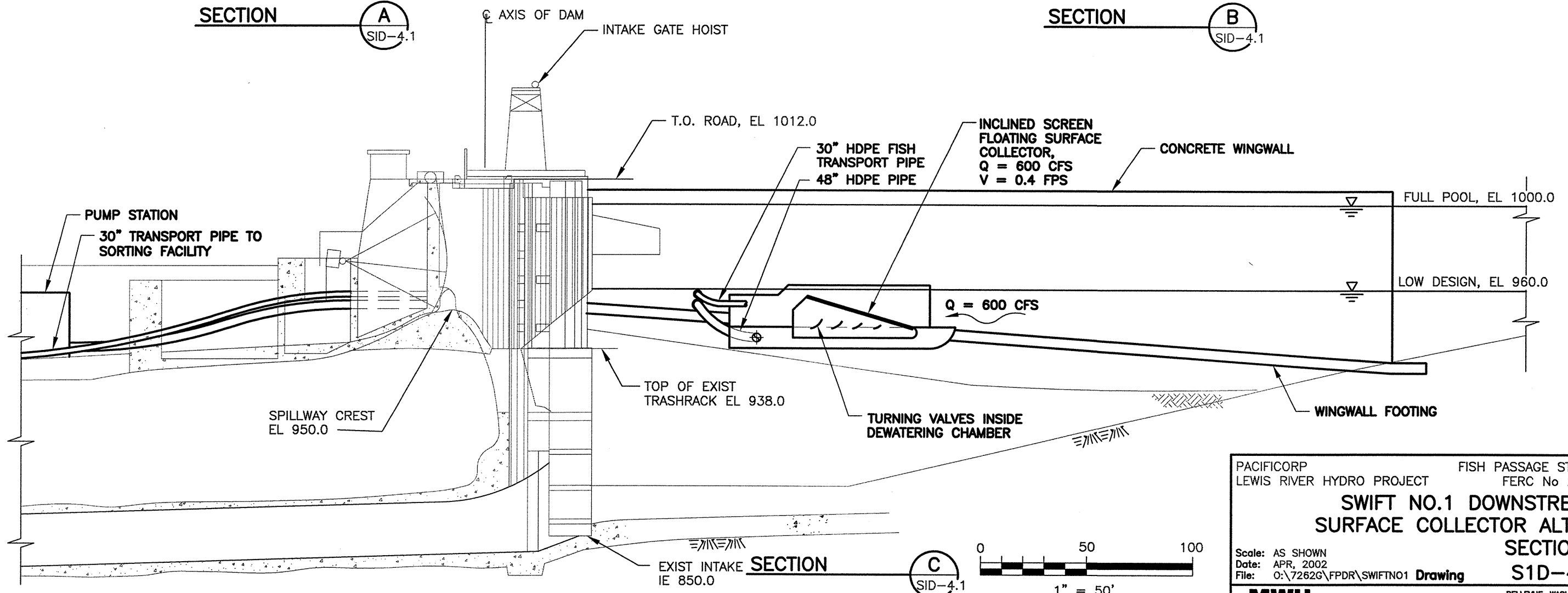

SECTION C
SID-4.1

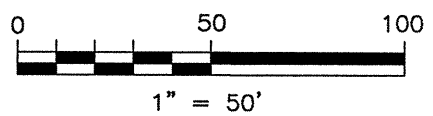

PACIFICORP FISH PASSAGE STUDY
LEWIS RIVER HYDRO PROJECT FERC No 2111
SWIFT NO.1 DOWNSTREAM SURFACE COLLECTOR ALT 2 SECTIONS
S1D-4.2
Scale: AS SHOWN
Date: APR, 2002
File: O:\7262G\FPDR\SWIFTNO1 Drawing
MWH BELLEVUE, WASHINGTON (425) 602-4000

N:\hupprich 10/28/02 3:24 PM

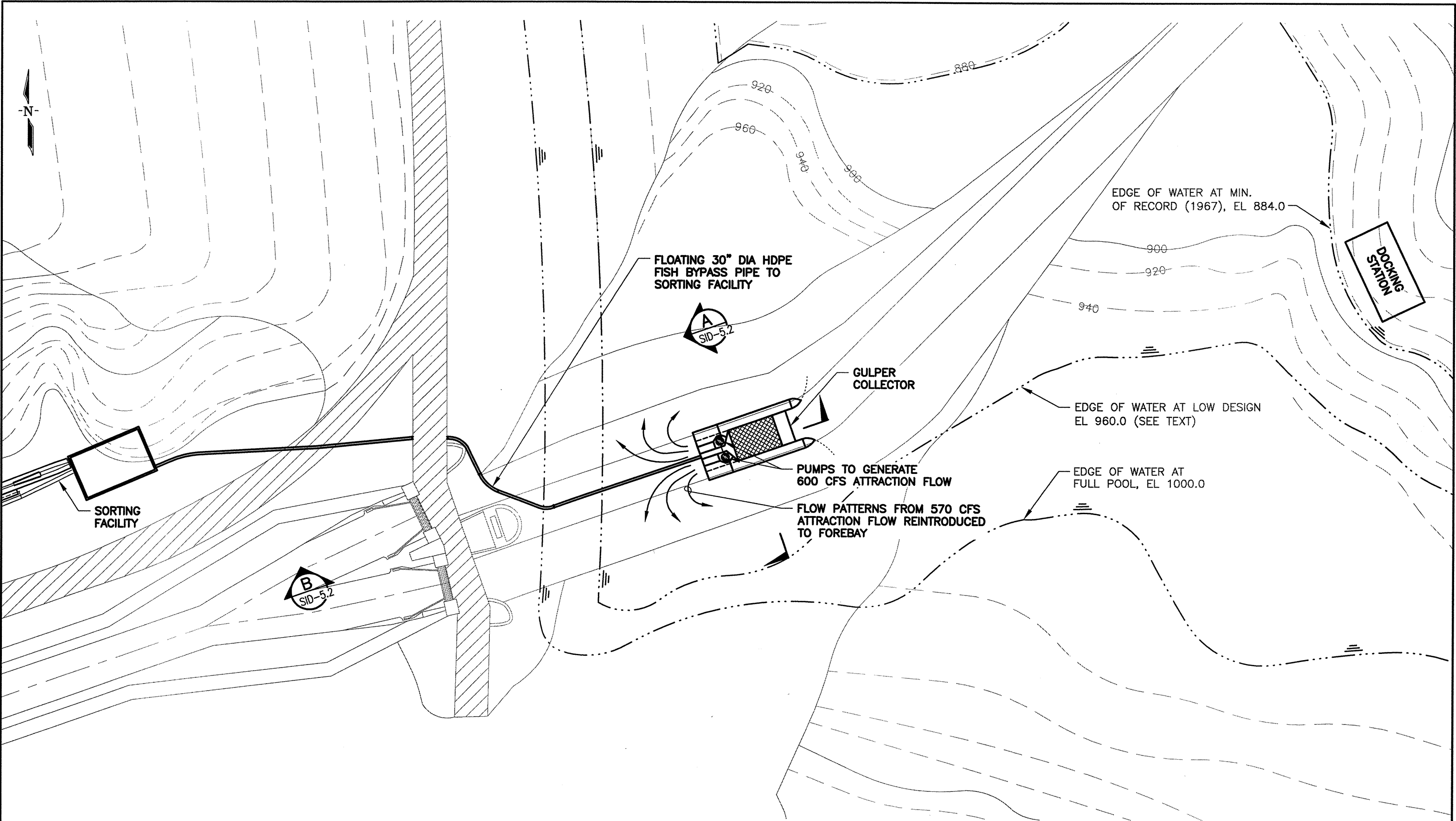

PLAN

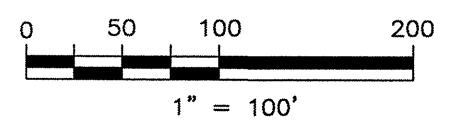

PACIFICORP LEWIS RIVER HYDRO PROJECT	FISH PASSAGE STUDY FERC No 2111
SWIFT NO.1 DOWNSTREAM GULPER COLLECTOR	
PLAN	
Scale: 1" = 100'	S1D-5.1
Date: APR, 2002	
File: 0:\7262G\FPDR\SWIFTNO1	Drawing
MWH	
<small>BELLEVUE, WASHINGTON (425) 602-4000</small>	

N:\supprich 10/28/02 3:26 PM

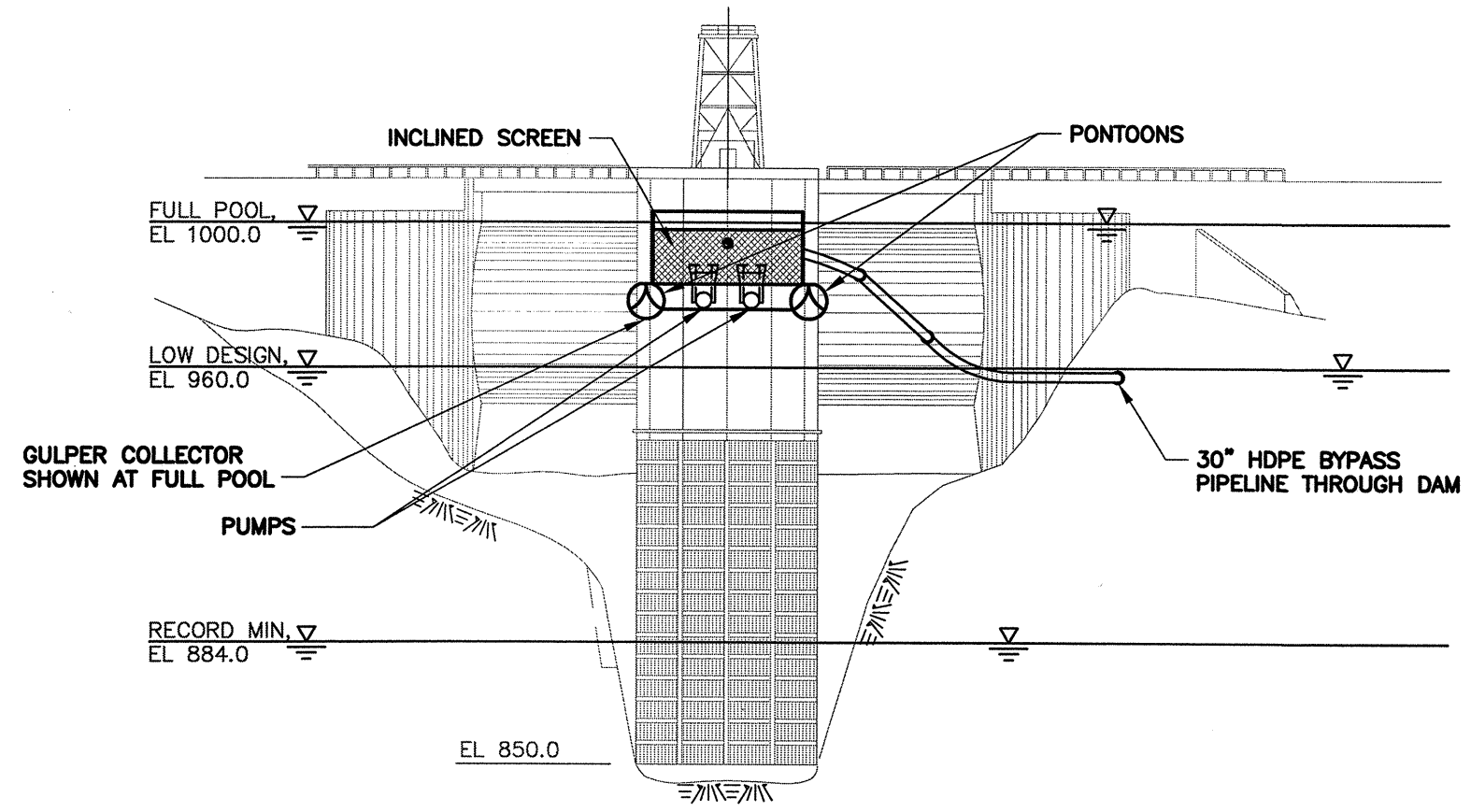

SECTION A
SID-5.1

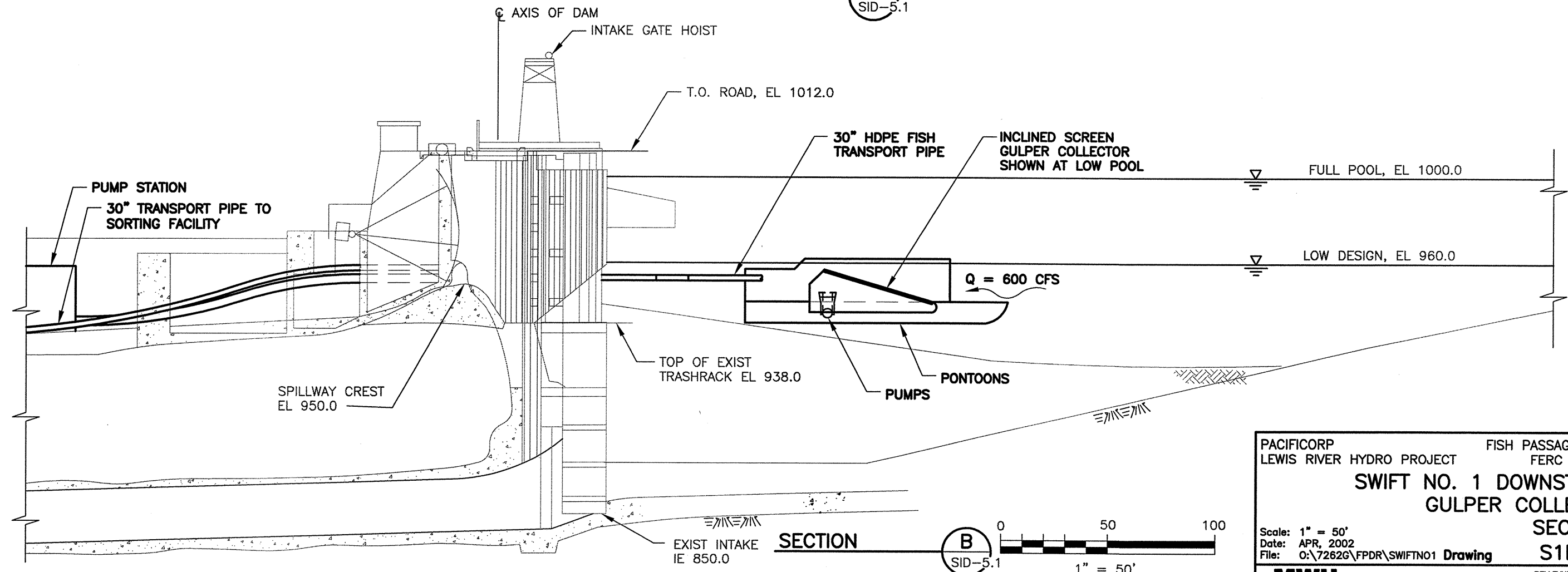

SECTION B
SID-5.1

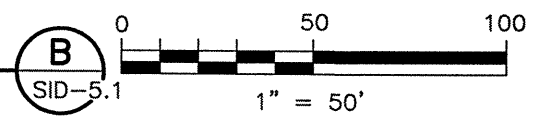

PACIFICORP LEWIS RIVER HYDRO PROJECT	FISH PASSAGE STUDY FERC No 2111
SWIFT NO. 1 DOWNSTREAM GULPER COLLECTOR SECTIONS	
S1D-5.2	
Scale: 1" = 50'	Date: APR, 2002
File: O:\7262G\FPDR\SWIFTN01	Drawing
MWH	
<small>BELLEVUE, WASHINGTON (425) 602-4000</small>	

NHupprich 10/28/02 3:27 PM

Tab C

Appendices:

*Appendix A – WDFW Comment Letter on Phase 1 Report
Dated September 10, 2001*

Appendix B – Facility Cost Estimate Spreadsheets

Appendix A

*WDFW Comment Letter on Phase 1 Report
Dated September 10, 2001*



State of Washington
DEPARTMENT OF FISH AND WILDLIFE

Mailing Address: 600 Capitol Way N • Olympia, WA 98501-1091 • (360) 902-2200, TDD (360) 902-2207
Main Office Location: Natural Resources Building • 1111 Washington Street SE • Olympia, WA

September 10, 2001

Frank Shrier
PacifiCorp
825 Northeast Multnomah Suite 1500
Portland, Oregon 97232

Diana MacDonald
Cowlitz PUD
Box No. 3007
980 Commerce Avenue
Longview, Washington 98632

Dana Postlewaite
Montgomery Watson Harza
2353 130th Avenue Northeast Suite 200
Bellevue, Washington 98009

Dear Colleagues:

Subject: AQU5 Engineering Feasibility Study for Fish Passage Facilities Technical Review Comments

The Washington Department of Fish and Wildlife (WDFW) has reviewed the AQU5 Engineering Feasibility Study for Fish Passage Facilities and provide the following comments. Comments that would equally be applied at each site, facility, or component are listed once to avoid duplication but are referenced.

UPSTREAM PASSAGE FACILITIES

2.2.2, 2.2.3, 2.2.4

The hydrology standard generally accepted for the design and operation of upstream fish passage, is for the fish passage criteria to be complied with 90% of the time during the migration period, rather than for the flows between the annual 10 and 90% exceedence flows. The standard should be applied to each migration period (species) of interest. Downstream passage facilities should ideally be designed to be functional at all flows, but some facilities such as operation of an in-river screen may require special consideration.

RECEIVED

HARZA ENGINEERING CO.

Information on frequency and rate of spill by month would be helpful.

Extreme low tailwater elevations at Merwin should be provided. Explanations of the extreme low forebay elevations at Merwin in September through November (Figure 2.3-1), and at Yale in February through April (Figure 2.3-3), should be provided; are they expected to occur again?

Biological Considerations and Goals

Biological considerations, and goals and species considered for passage, are subjects of other discussions; we won't comment on them here.

Merwin upstream passage

4.1

Draft tube barriers are not discussed. Fish may be injured by direct runner strike or by shear forces in the draft tubes. Draft tube study results or details, such as runner elevations and draft tube geometries and velocities, should be provided to help determine if there is a risk of fish injury at the runners or within the draft tubes. Otherwise, draft tube barrier designs should be included as part of the fish passage facilities.

Regardless of the facility selected, a sorting facility will be needed for collection of hatchery stock.

4.1.1.2

There is some concern whether all species will move through a volitional fishway of the lengths and heights needed for these projects. Some fish may reject the fishways due to length. Because of cumulative loss, even with a hypothetical 99.9% per-weir success rate for any species, a 200-foot high fishway would have an overall effectiveness of 80%.

Additionally some fish may stop their upstream movement and try to move back downstream at night. Large holding ponds and/or traps to prevent downstream passage may have to be included. Such facilities may or may not comply with the definition of volitional passage.

The passage efficiency through such high fishways is a significant uncertainty. This uncertainty cannot be reduced without significant and complex studies or the construction and evaluation of the fishways themselves. Studies would have to resolve per-weir fish passage success to a precision greater than the hypothetical 99.9% in the example above.

Traps with transfer and haul facilities should be designed at each site as backup measures in case fishways aren't successful.

It is not clear what modifications are suggested to the existing fish lift to accommodate the fishway. The fish lift system should include adequate holding, trapping and lifting capacity, auxiliary water for attraction, and a crowding system.

Have other less costly fishway alignments been considered? A fishway collection channel alignment that routes fish to the north end of the powerhouse might be a viable alternative and save some expense of building the fishway on the rock wall on the south side. From the north end of the powerhouse, the fishway could switch back in the area north of the powerhouse and go under the spillway or it might cross the face of the powerhouse or behind the powerhouse.

4.1.1.3

The issues previously brought up by WDFW, and mentioned in the report, should be specifically addressed in the final report. They include considerations of fishway entrance flow, number and location, and trap size and location. These are basic considerations to the design of fish facilities at Merwin.

The proposed number of fishway entrances and fishway entrance flow is not clear in the text or drawings. The single fishway entrance with a flow of 33 cfs is considerably less than what has proven successful at other sites. Considering the length of the powerhouse and the possible operational variations and flow patterns in the tailrace, multiple entrances and substantially more fishway entrance flow should be provided. The entrance flow criteria suggested for Yale are appropriate at all sites for a planning-level study. An auxiliary water supply and diffusion system would be required.

Depending on hydraulic conditions over other draft tubes, it may not be appropriate for fishway entrances to be located directly over draft tubes. Videotape documentation of tailrace flow patterns should be provided at a range of flows and unit operation. A physical model may be required to fully understand tailwater conditions. An explanation of turbine unit operation would also be helpful. How are units sequenced in operation? Is priority likely to change as the units age?

The minimum design tailwater elevation is shown as 47.0. Based on the tailwater information in Figure 2.3-2, a slightly lower elevation is suggested. Entrance gates should be overflow rather than underflow gates. Overflow gates would include a notch for swim-through fish passage. Overflow gates allow better light conditions in the entrance pool, allow easy observation of operation and fish usage and are further separated from the draft tubes during high flows.

4.1.1.4

To control the fishway flow, the outlet gates have to be throttled. Minimum gate opening and maximum head criteria for throttling the gates should be provided. Additional pool volume and special geometry may be required for energy dissipation of the throttled jets. A system with adjustable fishway weirs and fewer outlet gates should be investigated. No further detail is needed for feasibility level design.

More information is needed on the reservoir flow patterns in order to appropriately site the fishway exit.

4.1.2

Multiple fish lifting, transferring and truck loading and unloading, should be avoided if possible.

4.1.4

A benefit of a fish lift is that a single system could move fish to the reservoir, a sorting facility, or to a truck for hauling. The release device would have to be designed to release fish at the surface of all expected reservoir water levels. Cycle time will be more critical on higher projects. To provide flexibility of cycle time, the capability of multiple hoppers within a single lift system should be included in the design.

Yale upstream passage

4.2

See comments on Merwin regarding:

- Draft tube barriers
- Documentation of tailrace hydraulics
- Height of fishway
- Reservoir surface flow patterns
- Fishway exit geometry
- Multiple hoppers

4.2.1.2

The fishway entrances should be located to best accommodate tailrace flow patterns. Entrances at each end of the powerhouse are likely needed. A reasonable fishway entrance flow for planning purposes is suggested; an auxiliary water supply should be included on the sketches.

4.2.2

The plans suggest that the trap-and-haul facilities would be located 30 feet above the powerhouse deck; they can likely be lower than that.

Swift upstream passage

4.3

See comments on Merwin regarding:

- Draft tube barriers
- Documentation of tailrace hydraulics
- Height of fishway
- Reservoir surface flow patterns
- Fishway exit geometry
- Multiple hoppers

4.3.1.3

Multiple fishway entrances would likely be needed at Swift 2.

4.3.1.4

It's my understanding that water is spilled from the canal at the wasteway only for infrequently emergency conditions. The need for fish protection at the site should be reviewed if spill occurs more frequently than that, and if fish are in the reach.

DOWNSTREAM PASSAGE FACILITIES

Upper Swift juvenile facilities

5.1.1

Flow distribution and debris management will obviously be challenges in the design of an upstream collector. Physical model studies will likely be needed.

The 90% exceedence flow capacity of the screen may or may not be appropriate. The screen design capacity will likely depend partially on flow timing and debris. More information on timing of peak flows, magnitude of spring peak flows, and debris would be helpful.

The WDFW screen criterion of 0.4 fps approach velocity is for an extreme condition of small fish and cold water. That approach velocity can likely be exceeded when the severe conditions are not present. The screen exposure time of 60 seconds can also likely be exceeded; I suggest doubling it.

It appears that operation of the screen at full capacity is expected as part of the total hydraulic capacity. The screen won't likely operate at highest flows because of debris problems.

Management of debris within the secondary dewatering and sampling facilities will be difficult. Consider using a screen cleaner that will lift debris over the screens rather than sweeping it into the bypass.

Swift No1 dam downstream passage facilities

See comments on the upper Swift juvenile screen regarding:

Approach velocity criteria

Fish passage from large reservoirs may benefit by artificial freshets or passing natural freshets. Screen design would have to accommodate the capacity of freshets if they are potentially part of the fish passage scheme.

5.2.3

The design presented for the gulper is somewhat simplistic. Guide nets have contributed to the relative success of the gulper at Baker. The nets work at that site because reservoir flow and

wind patterns and a concentration of debris. Even there, passage efficiency has varied in subsequent years from 27 to 73% for coho without clear reason.

The design of the gulper bypass is not clear. Additional detail is needed on how energy is dissipated at the intermediate bypass chamber.

LOWER BASIN STRESS RELIEF PONDS

5.4.1

Water supplies for any stress release ponds and/or fish release sites must consider temperature acclimation and water supply to enhance homing of returning adults.

FISH PASSAGE SYSTEM DEVELOPMENT

At this point WDFW recommends the system described as follows be included in continuing feasibility evaluations:

- System 3, Anadromous reintroduction above Swift,
- Juvenile collector at Swift #1 Dam including an exclusion screen with adequate flow for attraction,
- System 4, Reconnect Swift and Yale bull trout populations using the juvenile collector for System 3 but without the juvenile bypass to Merwin.

Specifically this would include the following facilities:

Merwin

Adult trap and haul with or without tram
Adult sorting and counting station
Draft tube barrier

Yale

Adult trap and haul suitable for bull trout

Swift

Adult trap and haul suitable for bull trout
Draft tube barriers
Fish collection and screening at dam.
Juvenile / bull trout trap, sorting and haul.

This recommendation is made for the reasons stated here and in the draft feasibility study. Adaptability and flexibility are important decision criteria that we've included in our review. The passage efficiency through such high fishways is a significant uncertainty. This uncertainty cannot be reduced without significant and complex studies or the construction and evaluation of the fishways themselves.

We recognize that trams and trap-and-haul facilities have greater mechanical risk and are certainly not natural. It is very likely that "natural" solutions do not exist for such an unnatural situation. Mechanical facilities would be state of the art facilities with certainty, flexibility and adaptability that fishways would not offer.

Appropriate mitigation will be required for habitat not accessed and for other effects of the projects.

Respectfully,

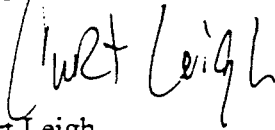

Curt Leigh
Scientist



Ken Bates
Chief Environmental Engineer

cc: ARG members

Appendix B

Facility Cost Estimate Spreadsheets

Appendix B

Phase 2 Fish Passage Facility Cost Estimate

This appendix includes detailed cost estimates of individual fish passage facilities. See text for assumptions associated with these estimates

**Relicensing Fish Passage Study
Lewis River Hydroelectric Projects
Draft Level Cost Estimate
February, 2001**

Merwin Dam Fish Ladder

<u>Item</u>	<u>Quantity</u>	<u>Unit</u>	<u>Unit Cost</u>	<u>Cost</u>
Ladder Entrance				
Modified fish tunnel for 3 entrances	1	EA	\$ 125,000	\$ 125,000
			Item Subtotal	\$ 125,000
			Construction Contingencies (30%)	\$ 37,500
			SUBTOTAL, CONSTRUCTION COSTS	\$ 162,500
			Engineering, Permitting and Administration (25% of Construction)	40,625
			TOTAL ITEM COST	\$ 203,125
			ROUNDED TOTAL	\$ 203,000

Ladder

Concrete	3,300	CY	\$ 750	\$ 2,475,000
Sheet piling	60,000	SF	\$ 25	\$ 1,500,000
Sheet piling concrete sill/seal	1,000	CY	\$ 850	\$ 850,000
Steel walers and sheet pile bracing	300,000	LB	\$ 5	\$ 1,500,000
Excavation	50,000	CY	\$ 17	\$ 850,000
Access road crushed rock surfacing	235	CY	\$ 15	\$ 3,525
			Item Subtotal	\$ 7,178,525
			Construction Contingencies (30%)	\$ 2,153,558
			SUBTOTAL, CONSTRUCTION COSTS	\$ 9,332,083
			Engineering, Permitting and Administration (25% of Construction)	2,333,021
			TOTAL ITEM COST	\$ 11,665,103
			ROUNDED TOTAL	\$ 11,665,000

Ladder Exit

Sheet piling	24,000	SF	\$ 25	\$ 600,000
Steel walers and sheet pile bracing	60,000	LB	\$ 5	\$ 300,000
Concrete	1,400	CY	\$ 750	\$ 1,050,000
Adjustable wiers	14	EA	\$ 27,000	\$ 378,000
Excavation	2,000	CY	\$ 17	\$ 34,000
Fill	650	CY	\$ 10	\$ 6,500
Access road crushed rock surfacing	75	CY	\$ 15	\$ 1,125
Electrical Mechanical Controls	1	LS	\$ 190,000	\$ 190,000
Concrete Retaining Wall	550	CY	\$ 750	\$ 412,500
			Item Subtotal	\$ 2,972,125
			Construction Contingencies (30%)	\$ 891,638
			SUBTOTAL, CONSTRUCTION COSTS	\$ 3,863,763
			Engineering, Permitting and Administration (25% of Construction)	965,941
			TOTAL ITEM COST	\$ 4,829,703
			ROUNDED TOTAL	\$ 4,830,000

**Relicensing Fish Passage Study
Lewis River Hydroelectric Projects
Draft Level Cost Estimate
February, 2001**

Merwin Dam Trap and Haul Alt-1

<u>Item</u>	<u>Quantity</u>	<u>Unit</u>	<u>Unit Cost</u>	<u>Cost</u>
Sorting/Sampling and Holding Facility				
Excavation	9,300	CY	\$ 17	\$ 158,100
Enlarge fish lift	1	LS	\$ 1,200,000	\$ 1,200,000
Access road crushed rock surfacing	360	CY	\$ 10	\$ 3,600
Fiberglass holding tanks	4	EA	\$ 18,000	\$ 72,000
Concrete retaining wall	51	CY	\$ 750	\$ 38,250
Concrete footings	72	CY	\$ 750	\$ 54,000
Structural steel	44,100	LB	\$ 5	\$ 220,500
Grating	4,160	SF	\$ 30	\$ 124,800
Concrete (aeration/distribution tower)	1	LS	\$ 51,000	\$ 51,000
Sorting flume assembly	1	LS	\$ 65,000	\$ 65,000
Water supply pumps and intake gate	1	LS	\$ 250,000	\$ 250,000
Water supply pipe	400	LF	\$ 95	\$ 38,000
Sampling and biological work-up bldg.	1,250	SF	\$ 63	\$ 78,750
Transport flume	1	LS	\$ 200,000	\$ 200,000
Sorting operators booth	144	SF	\$ 72	\$ 10,368
			Item Subtotal	\$ 2,564,368
			Construction Contingencies (30%)	\$ 769,310
			SUBTOTAL, CONSTRUCTION COSTS	\$ 3,333,678
			Engineering, Permitting and Administration (25% of Construction)	833,420
			TOTAL PROJECT COST	\$ 4,167,098
			ROUNDED TOTAL	\$ 4,167,000

**Relicensing Fish Passage Study
Lewis River Hydroelectric Projects
Draft Level Cost Estimate
February, 2001**

Merwin Dam Trap and Haul Alt-2

<u>Item</u>	<u>Quantity</u>	<u>Unit</u>	<u>Unit Cost</u>	<u>Cost</u>
Ladder Entrance				
Modified fish tunnel for 3 entrances	1	EA	\$ 125,000	\$ 125,000
			Item Subtotal	\$ 125,000
			Construction Contingencies (30%)	\$ 37,500
			SUBTOTAL, CONSTRUCTION COSTS	\$ 162,500
			Engineering, Permitting and Administration (25% of Construction)	40,625
			TOTAL PROJECT COST	\$ 203,125
			ROUNDED TOTAL	\$ 203,000
Ladder to holding and sorting facility				
Concrete	1,500	CY	\$ 750	\$ 1,125,000
Sheet piling	60,000	SF	\$ 25	\$ 1,500,000
Sheet piling concrete sill/seal	1,000	CY	\$ 850	\$ 850,000
Steel walers and sheet pile bracing	300,000	LB	\$ 5	\$ 1,500,000
Excavation	16,200	CY	\$ 17	\$ 275,400
Fill	4,000	CY	\$ 10	\$ 40,000
			Item Subtotal	\$ 5,290,400
			Construction Contingencies (30%)	\$ 1,587,120
			SUBTOTAL, CONSTRUCTION COSTS	\$ 6,877,520
			Engineering, Permitting and Administration (25% of Construction)	1,719,380
			TOTAL PROJECT COST	\$ 8,596,900
			ROUNDED TOTAL	\$ 8,597,000
Excavation	2,400	CY	\$ 17	\$ 40,800
Access road crushed rock surfacing	150	CY	\$ 10	\$ 1,500
Fiberglass holding tanks	4	EA	\$ 18,000	\$ 72,000
Concrete retaining wall	51	CY	\$ 750	\$ 38,250
Concrete footings	72	CY	\$ 750	\$ 54,000
Structural steel	44,100	LB	\$ 5	\$ 220,500
Grating	4,160	SF	\$ 30	\$ 124,800
Concrete (aeration/distribution tower)	1	LS	\$ 51,000	\$ 51,000
Sorting flume assembly	1	LS	\$ 65,000	\$ 65,000
Water supply pumps and intake gate	1	LS	\$ 250,000	\$ 250,000
Water supply pipe	400	LF	\$ 95	\$ 38,000
Sampling and biological work-up bldg.	1,250	SF	\$ 63	\$ 78,750
Sorting operators booth	144	SF	\$ 72	\$ 10,368
			Item Subtotal	\$ 1,044,968
			Construction Contingencies (30%)	\$ 313,490
			SUBTOTAL, CONSTRUCTION COSTS	\$ 1,358,458
			Engineering, Permitting and Administration (25% of Construction)	339,615
			TOTAL PROJECT COST	\$ 1,698,073
			ROUNDED TOTAL	\$ 1,698,000
			Facility Total	\$ 10,498,000

Relicensing Fish Passage Study
Lewis River Hydroelectric Projects
Draft Level Cost Estimate
 February, 2001

Merwin Dam Fish Lift to Reservoir Alt A
--

<u>Item</u>	<u>Quantity</u>	<u>Unit</u>	<u>Unit Cost</u>	<u>Cost</u>
Tramway Facility				
Loading Facility	1	LS	\$ 600,000	\$ 600,000
Tramway	1	LS	\$ 1,000,000	\$ 1,000,000
Trap Release Structure	1	LS	\$ 400,000	\$ 400,000
			Item Subtotal	\$ 2,000,000
			Construction Contingencies (30%)	\$ 600,000
			SUBTOTAL, CONSTRUCTION COSTS	\$ 2,600,000
			Engineering, Permitting and Administration (25% of Construction)	650,000
			TOTAL PROJECT COST	\$ 3,250,000
			ROUNDED TOTAL	\$ 3,250,000

**Relicensing Fish Passage Study
Lewis River Hydroelectric Projects
Draft Level Cost Estimate
February, 2001**

Merwin Dam Fish Lift to Reservoir Alt B					
<u>Item</u>	<u>Quantity</u>	<u>Unit</u>	<u>Unit Cost</u>	<u>Cost</u>	
Ladder Entrance					
Modified fish tunnel for 3 entrances	1	EA	\$ 125,000	\$	125,000
			Item Subtotal	\$	125,000
			Construction Contingencies (30%)	\$	37,500
			SUBTOTAL, CONSTRUCTION COSTS	\$	162,500
			Engineering, Permitting and Administration (25% of Construction)		40,625
			TOTAL ITEM COST	\$	203,125
			ROUNDED TOTAL	\$	203,000
Ladder to holding and sorting facility					
Sheet piling	60,000	SF	\$ 25	\$	1,500,000
Sheet piling concrete sill/seal	1,000	CY	\$ 850	\$	850,000
Steel walers and sheet pile bracing	300,000	LB	\$ 5	\$	1,500,000
Fish ladder entrance gate (3 Leaf)	2	EA	\$ 27,000	\$	54,000
Concrete	1,500	CY	\$ 750	\$	1,125,000
Excavation	16,200	CY	\$ 17	\$	275,400
Fill	4,000	CY	\$ 10	\$	40,000
			Item Subtotal	\$	5,344,400
			Construction Contingencies (30%)	\$	1,603,320
			SUBTOTAL, CONSTRUCTION COSTS	\$	6,947,720
			Engineering, Permitting and Administration (25% of Construction)		1,736,930
			TOTAL PROJECT COST	\$	8,684,650
			ROUNDED TOTAL	\$	8,685,000
Trap and Haul Holding and Sorting Facility					
Excavation	2,400	CY	\$ 17	\$	40,800
Access road crushed rock surfacing	150	CY	\$ 10	\$	1,500
Fiberglass holding tanks	4	EA	\$ 18,000	\$	72,000
Concrete retaining wall	51	CY	\$ 750	\$	38,250
Concrete footings	72	CY	\$ 750	\$	54,000
Structural steel	44,100	LB	\$ 5	\$	220,500
Grating	4,160	SF	\$ 30	\$	124,800
Concrete (aeration/distribution tower)	1	LS	\$ 51,000	\$	51,000
Sorting flume assembly	1	LS	\$ 65,000	\$	65,000
Water supply pumps and intake gate	1	LS	\$ 250,000	\$	250,000
Water supply pipe	400	LF	\$ 95	\$	38,000
Sampling and biological work-up bldg.	1,250	SF	\$ 63	\$	78,750
Sorting operators booth	144	SF	\$ 72	\$	10,368
			Item Subtotal	\$	1,044,968
			Construction Contingencies (30%)	\$	313,490
			SUBTOTAL, CONSTRUCTION COSTS	\$	1,358,458
			Engineering, Permitting and Administration (25% of Construction)		339,615
			TOTAL PROJECT COST	\$	1,698,073
			ROUNDED TOTAL	\$	1,698,000
Tramway Facility					
Loading Facility	1	LS	\$ 600,000	\$	600,000
Tramway	1	LS	\$ 1,000,000	\$	1,000,000
Trap Release Structure	1	LS	\$ 400,000	\$	400,000
			Item Subtotal	\$	2,000,000
			Construction Contingencies (30%)	\$	600,000
			SUBTOTAL, CONSTRUCTION COSTS	\$	2,600,000
			Engineering, Permitting and Administration (25% of Construction)		650,000
			TOTAL PROJECT COST	\$	3,250,000
			ROUNDED TOTAL	\$	3,250,000

**Relicensing Fish Passage Study
Lewis River Hydroelectric Projects
Draft Level Cost Estimate
February, 2001**

Yale Dam Fish Ladder					
<u>Item</u>	<u>Quantity</u>	<u>Unit</u>	<u>Unit Cost</u>	<u>Cost</u>	
Ladder Entrance					
Concrete	600	CY	\$ 750	\$	450,000
Fish ladder entrance gate (3 Leaf)	3	EA	\$ 27,000	\$	81,000
Sheet piling	60,000	SF	\$ 25	\$	1,500,000
Sheet piling concrete sill/seal	1,000	CY	\$ 850	\$	850,000
Steel walers and sheet pile bracing	300,000	LB	\$ 5	\$	1,500,000
Pipe for attraction water jet	800	LF	\$ 70	\$	56,000
Attraction water gate valve	1	EA	\$ 21,000	\$	21,000
			Item Subtotal	\$	4,458,000
			Construction Contingencies (30%)	\$	1,337,400
			SUBTOTAL, CONSTRUCTION COSTS	\$	5,795,400
			Engineering, Permitting and Administration (25% of Construction)		1,448,850
			TOTAL PROJECT COST	\$	7,244,250
			ROUNDED TOTAL	\$	7,244,000
Ladder					
Concrete	5,400	CY	\$ 750	\$	4,050,000
Excavation	100,000	CY	\$ 17	\$	1,700,000
Access road crushed rock surfacing	715	CY	\$ 15	\$	10,725
			Item Subtotal	\$	5,760,725
			Construction Contingencies (30%)	\$	1,728,218
			SUBTOTAL, CONSTRUCTION COSTS	\$	7,488,943
			Engineering, Permitting and Administration (25% of Construction)		1,872,236
			TOTAL PROJECT COST	\$	9,361,178
			ROUNDED TOTAL	\$	9,361,000
Ladder Exit					
Sheet piling	24,000	SF	\$ 25	\$	600,000
Steel walers and sheet pile bracing	60,000	LB	\$ 5	\$	300,000
Concrete	1,700	CY	\$ 750	\$	1,275,000
Adjustable weirs	17	EA	\$ 27,000	\$	459,000
Excavation	7,000	CY	\$ 17	\$	119,000
Fill	200	CY	\$ 10	\$	2,000
Access road crushed rock surfacing	100	CY	\$ 15	\$	1,500
Electrical Mechanical Controls	1	LS	\$ 190,000	\$	190,000
Retaining Wall	350	CY	\$ 750	\$	262,500
			Item Subtotal	\$	3,209,000
			Construction Contingencies (30%)	\$	962,700
			SUBTOTAL, CONSTRUCTION COSTS	\$	4,171,700
			Engineering, Permitting and Administration (25% of Construction)		1,042,925
			TOTAL PROJECT COST	\$	5,214,625
			ROUNDED TOTAL	\$	5,215,000

**Relicensing Fish Passage Study
Lewis River Hydroelectric Projects
Draft Level Cost Estimate
February, 2001**

Yale Dam Trap and Haul

<u>Item</u>	<u>Quantity</u>	<u>Unit</u>	<u>Unit Cost</u>	<u>Cost</u>
Ladder Entrance				
Concrete	600	CY	\$ 750	\$ 450,000
Sheet piling	60,000	SF	\$ 25	\$ 1,500,000
Sheet piling concrete sill/seal	1,000	CY	\$ 850	\$ 850,000
Steel walers and sheet pile bracing	300,000	LB	\$ 5	\$ 1,500,000
Fish ladder entrance gate (3 Leaf)	3	EA	\$ 27,000	\$ 81,000
			Item Subtotal	\$ 4,381,000
			Construction Contingencies (30%)	\$ 1,314,300
			SUBTOTAL, CONSTRUCTION COSTS	\$ 5,695,300
			Engineering, Permitting and Administration (25% of Construction)	1,423,825
			TOTAL PROJECT COST	\$ 7,119,125
			ROUNDED TOTAL	\$ 7,119,000

Ladder to holding and sorting facility				
Concrete	1,000	CY	\$ 750	\$ 750,000
Excavation	6,000	CY	\$ 17	\$ 102,000
			Item Subtotal	\$ 852,000
			Construction Contingencies (30%)	\$ 255,600
			SUBTOTAL, CONSTRUCTION COSTS	\$ 1,107,600
			Engineering, Permitting and Administration (25% of Construction)	276,900
			TOTAL PROJECT COST	\$ 1,384,500
			ROUNDED TOTAL	\$ 1,385,000

Trap and Haul Holding and Sorting Facility				
Excavation	2,400	CY	\$ 17	\$ 40,800
Access road crushed rock surfacing	150	CY	\$ 10	\$ 1,500
Fiberglass holding tanks	4	EA	\$ 18,000	\$ 72,000
Concrete retaining wall	51	CY	\$ 750	\$ 38,250
Concrete footings	72	CY	\$ 750	\$ 54,000
Structural steel	44,100	LB	\$ 5	\$ 220,500
Grating	4,160	SF	\$ 30	\$ 124,800
Concrete (aeration/distribution tower)	1	LS	\$ 51,000	\$ 51,000
Sorting flume assembly	1	LS	\$ 65,000	\$ 65,000
Water supply pumps and intake gate	1	LS	\$ 250,000	\$ 250,000
Water supply pipe	400	LF	\$ 95	\$ 38,000
Sampling and biological work-up bldg.	1,250	SF	\$ 63	\$ 78,750
Sorting operators booth	144	SF	\$ 72	\$ 10,368
			Item Subtotal	\$ 1,044,968
			Construction Contingencies (30%)	\$ 313,490
			SUBTOTAL, CONSTRUCTION COSTS	\$ 1,358,458
			Engineering, Permitting and Administration (25% of Construction)	339,615
			TOTAL PROJECT COST	\$ 1,698,073
			ROUNDED TOTAL	\$ 1,698,000

Relicensing Fish Passage Study
Lewis River Hydroelectric Projects
Draft Level Cost Estimate
 February, 2001

Yale Dam Fish Lift to Reservoir Alt A
--

<u>Item</u>	<u>Quantity</u>	<u>Unit</u>	<u>Unit Cost</u>	<u>Cost</u>
Tramway Facility				
Loading Facility	1	LS	\$ 600,000	\$ 600,000
Tramway	1	LS	\$ 1,500,000	\$ 1,500,000
Trap Release Structure	1	LS	\$ 400,000	\$ 400,000
			Item Subtotal	\$ 2,500,000
			Construction Contingencies (30%)	\$ 750,000
			SUBTOTAL, CONSTRUCTION COSTS	\$ 3,250,000
			Engineering, Permitting and Administration (25% of Construction)	812,500
			TOTAL PROJECT COST	\$ 4,062,500
			ROUNDED TOTAL	\$ 4,063,000

**Relicensing Fish Passage Study
Lewis River Hydroelectric Projects
Draft Level Cost Estimate
February, 2001**

Swift Complex Fish Ladder

<u>Item</u>	<u>Quantity</u>	<u>Unit</u>	<u>Unit Cost</u>	<u>Cost</u>
Swift No. 2 Ladder Entrance				
Concrete	600	CY	\$ 750	\$ 450,000
Fish ladder entrance gate (3 Leaf)	3	EA	\$ 27,000	\$ 81,000
Sheet piling	20,000	SF	\$ 25	\$ 500,000
Sheet piling concrete sill/seal	350	CY	\$ 850	\$ 297,500
Steel walers and sheet pile bracing	100,000	LB	\$ 5	\$ 500,000
Pipe for attraction water jet	800	LF	\$ 70	\$ 56,000
Attraction water gate valve	1	EA	\$ 21,000	\$ 21,000
			Item Subtotal	\$ 1,905,500
			Construction Contingencies (30%)	\$ 571,650
			SUBTOTAL, CONSTRUCTION COSTS	\$ 2,477,150
			Engineering, Permitting and Administration (25% of Construction)	619,288
			TOTAL PROJECT COST	\$ 3,096,438

ROUNDED TOTAL **\$ 3,096,000**

Swift No. 2 Ladder				
Concrete	13,100	CY	\$ 750	\$ 9,825,000
Excavation	357,000	CY	\$ 17	\$ 6,069,000
Access road crushed rock surfacing	2,000	CY	\$ 10	\$ 20,000
Swift No. 2 Fish Channel				
Fill	50,000	CY	\$ 10	\$ 500,000
Access road crushed rock surfacing	2,500	CY	\$ 10	\$ 25,000
			Item Subtotal	\$ 16,439,000
			Construction Contingencies (30%)	\$ 4,931,700
			SUBTOTAL, CONSTRUCTION COSTS	\$ 21,370,700
			Engineering, Permitting and Administration (25% of Construction)	5,342,675
			TOTAL PROJECT COST	\$ 26,713,375

ROUNDED TOTAL **\$ 26,713,000**

Swift No. 1 Ladder Entrance				
Concrete	600	CY	\$ 750	\$ 450,000
Fish ladder entrance gate (3 Leaf)	3	EA	\$ 27,000	\$ 81,000
Pipe for attraction water jet	1,000	LF	\$ 95	\$ 95,000
Attraction water gate valve	1	EA	\$ 21,000	\$ 21,000
			Item Subtotal	\$ 647,000
			Construction Contingencies (30%)	\$ 194,100
			SUBTOTAL, CONSTRUCTION COSTS	\$ 841,100
			Engineering, Permitting and Administration (25% of Construction)	210,275
			TOTAL PROJECT COST	\$ 1,051,375

ROUNDED TOTAL **\$ 1,051,000**

Swift No. 1 Ladder

Concrete	5,900	CY	\$ 750	\$ 4,425,000
Excavation	37,000	CY	\$ 17	\$ 629,000
Access road crushed rock surfacing	900	CY	\$ 10	\$ 9,000
			Item Subtotal	\$ 5,063,000
			Construction Contingencies (30%)	\$ 1,518,900
			SUBTOTAL, CONSTRUCTION COSTS	\$ 6,581,900
			Engineering, Permitting and Administration (25% of Construction)	1,645,475
			TOTAL PROJECT COST	\$ 8,227,375

ROUNDED TOTAL **\$ 8,227,000**

Swift Complex Ladder Exit Structure

Sheet piling	60,000	SF	\$ 25	\$ 1,500,000
Steel walers and sheet pile bracing	150,000	LB	\$ 5	\$ 750,000
Concrete	3,500	CY	\$ 750	\$ 2,625,000
Adjustable wiers	40	EA	\$ 27,000	\$ 1,080,000
Exit Gates	3	EA	\$ 27,000	\$ 81,000
Excavation	5,000	CY	\$ 17	\$ 85,000
Fill	1,625	CY	\$ 10	\$ 16,250
Access road crushed rock surfacing	190	CY	\$ 15	\$ 2,850
Electrical Mechanical Controls	1	LS	\$ 190,000	\$ 190,000
			Item Subtotal	\$ 6,330,100
			Construction Contingencies (30%)	\$ 1,899,030
			SUBTOTAL, CONSTRUCTION COSTS	\$ 8,229,130
			Engineering, Permitting and Administration (25% of Construction)	2,057,283
			TOTAL PROJECT COST	\$ 10,286,413

ROUNDED TOTAL **\$ 10,286,000**

Relicensing Fish Passage Study
Lewis River Hydroelectric Projects
Draft Level Cost Estimate
 February, 2001

Swift No. 1 Dam Fish Lift to Reservoir

<u>Item</u>	<u>Quantity</u>	<u>Unit</u>	<u>Unit Cost</u>	<u>Cost</u>
Tramway Facility				
Loading Facility	1	LS	\$ 600,000	\$ 600,000
Tramway	1	LS	\$ 2,000,000	\$ 2,000,000
Trap Release Structure	1	LS	\$ 400,000	\$ 400,000
			Item Subtotal	\$ 3,000,000
			Construction Contingencies (30%)	\$ 900,000
			SUBTOTAL, CONSTRUCTION COSTS	\$ 3,900,000
			Engineering, Permitting and Administration (25% of Construction)	975,000
			TOTAL PROJECT COST	\$ 4,875,000
			ROUNDED TOTAL	\$ 4,875,000

Relicensing Fish Passage Study
Lewis River Hydroelectric Projects
Draft Level Cost Estimate
 February, 2002

Swift No. 2 Dam Fish Lift to Reservoir

<u>Item</u>	<u>Quantity</u>	<u>Unit</u>	<u>Unit Cost</u>	<u>Cost</u>
Tramway Facility				
Loading Facility	1	LS	\$ 600,000	\$ 600,000
Tramway	1	LS	\$ 2,500,000	\$ 2,500,000
Trap Release Structure	1	LS	\$ 400,000	\$ 400,000
			Item Subtotal	\$ 3,500,000
			Construction Contingencies (30%)	\$ 1,050,000
			SUBTOTAL, CONSTRUCTION COSTS	\$ 4,550,000
			Engineering, Permitting and Administration (25% of Construction)	1,137,500
			TOTAL PROJECT COST	\$ 5,687,500
			ROUNDED TOTAL	\$ 5,688,000

**Relicensing Fish Passage Study
Lewis River Hydroelectric Projects
Draft Level Cost Estimate
February, 2001**

Swift No. 1 Exclusionary Screen 0.4 FPS

<u>Item</u>	<u>Quantity</u>	<u>Unit</u>	<u>Unit Cost</u>	<u>Cost</u>
Exclusionary V - Screen Facility				
Cofferdam sheet pile	500,000	SF	\$ 25	\$ 12,500,000
Cofferdam fill	7,500	CY	\$ 25	\$ 187,500
Trash Racks	10,500	SF	\$ 70	\$ 735,000
Concrete Screen Floor	6,000	CY	\$ 750	\$ 4,500,000
Adjustable bypass control gate	2	SF	\$ 25,000	\$ 50,000
Radial control gate	4	EA	\$ 35,000	\$ 140,000
V-Screen	12,000	SF	\$ 115	\$ 1,380,000
Concrete walls and screen framework	3,250	CY	\$ 750	\$ 2,437,500
Hydraulic rake screen cleaning system	8	EA	\$ 270,000	\$ 2,160,000
Walkway Grating	20,000	SF	\$ 30	\$ 600,000
Electrical/Mechanical Controls	1	LS	\$ 190,000	\$ 190,000
Cut	237,585	CY	\$ 28	\$ 6,652,380
Access Road Fill	3,500	CY	\$ 10	\$ 35,000
Haul	186,185	CY	\$ 10	\$ 1,861,850
Fill	51,400	CY	\$ 8	\$ 411,200
			Item Subtotal	\$ 33,840,430
			Construction Contingencies (30%)	\$ 10,152,129
			SUBTOTAL, CONSTRUCTION COSTS	\$ 43,992,559
			Engineering, Permitting and Administration (25% of Construction)	10,998,140
			TOTAL PROJECT COST	\$ 54,990,699
			ROUNDED TOTAL	\$ 54,991,000
Bypass Conduit and Head Dissipation Fac.				
Bypass pipe (34" HDPE) wet	238	LF	\$ 450	\$ 107,100
Concrete encasement	115	CY	\$ 1,000	\$ 115,000
Directional Drilling and Pipe encasement	450	LF	\$ 1,200	\$ 540,000
Bypass pipe (34" HDPE) dry	450	LF	\$ 570	\$ 256,500
Penstock to intake excavation	650	LF	\$ 350	\$ 227,500
Penstock coating	40,000	SF	\$ 4	\$ 160,000
Penstock to Intake	650	LF	\$ 2,450	\$ 1,592,500
Penstock Fabricated Bends	1	LS	\$ 35,000	\$ 35,000
Concrete Conduit	1,200	LS	\$ 1,000	\$ 1,200,000
Circ. To Rect. Transition	1	LS	\$ 12,000	\$ 12,000
			Item Subtotal	\$ 4,245,600
			Construction Contingencies (30%)	\$ 1,273,680
			SUBTOTAL, CONSTRUCTION COSTS	\$ 5,519,280
			Engineering, Permitting and Administration (25% of Construction)	1,379,820
			TOTAL PROJECT COST	\$ 6,899,100
			ROUNDED TOTAL	\$ 6,899,000
Subsampling/Sorting/Handling Facility				
Sorting/Handling Facility	1	LS	\$ 9,260,000	\$ 9,260,000
			Construction Subtotal	\$ 9,260,000
			Construction Contingencies (30%)	\$ 2,778,000
			SUBTOTAL, CONSTRUCTION COSTS	\$ 12,038,000
			Engineering, Permitting and Administration (25% of Construction)	3,009,500
			TOTAL PROJECT COST	\$ 15,047,500
			ROUNDED TOTAL	\$ 15,048,000

**Relicensing Fish Passage Study
Lewis River Hydroelectric Projects
Draft Level Cost Estimate
February, 2001**

Swift No. 1 Exclusionary Screen 0.8 FPS

<u>Item</u>	<u>Quantity</u>	<u>Unit</u>	<u>Unit Cost</u>	<u>Cost</u>
Exclusionary V - Screen Facility				
Cofferdam sheet pile	500,000	SF	\$ 25	\$ 12,500,000
Cofferdam fill	7,500	CY	\$ 25	\$ 187,500
Trash Racks	10,500	SF	\$ 70	\$ 735,000
Concrete Screen Floor	4,000	CY	\$ 750	\$ 3,000,000
Adjustable bypass control gate	2	LS	\$ 25,000	\$ 50,000
Radial control gate	2	EA	\$ 35,000	\$ 70,000
V-Screen	8,000	SF	\$ 115	\$ 920,000
Concrete walls and screen framework	2,500	CY	\$ 750	\$ 1,875,000
Hydraulic rake screen cleaning system	4	EA	\$ 270,000	\$ 1,080,000
Walkway Grating	20,000	SF	\$ 30	\$ 600,000
Electrical/Mechanical Controls	1	LS	\$ 190,000	\$ 190,000
Cut	167,000	CY	\$ 28	\$ 4,676,000
Access Road Fill	2,450	CY	\$ 10	\$ 24,500
Haul	130,000	CY	\$ 10	\$ 1,300,000
Fill	35,700	CY	\$ 8	\$ 285,600
			Item Subtotal	\$ 27,493,600
			Construction Contingencies (30%)	\$ 8,248,080
			SUBTOTAL, CONSTRUCTION COSTS	\$ 35,741,680
			Engineering, Permitting and Administration (25% of Construction)	\$ 8,935,420
			TOTAL PROJECT COST	\$ 44,677,100
			ROUNDED TOTAL	\$ 44,677,000

Bypass Conduit and Head Dissipation Fac.				
Bypass pipe (34" HDPE) wet	238	LF	\$ 450	\$ 107,100
Concrete encasement	115	CY	\$ 1,000	\$ 115,000
Directional Drilling and Pipe encasement	450	LF	\$ 1,200	\$ 540,000
Bypass pipe (34" HDPE) dry	450	LF	\$ 570	\$ 256,500
Penstock to intake excavation	650	LF	\$ 350	\$ 227,500
Penstock coating	40,000	SF	\$ 4	\$ 160,000
Penstock to Intake	650	LF	\$ 2,450	\$ 1,592,500
Penstock Fabricated Bends	1	LS	\$ 35,000	\$ 35,000
Concrete Conduit	1,200	LS	\$ 1,000	\$ 1,200,000
Circ. To Rect. Transition	1	LS	\$ 12,000	\$ 12,000
			Item Subtotal	\$ 4,245,600
			Construction Contingencies (30%)	\$ 1,273,680
			SUBTOTAL, CONSTRUCTION COSTS	\$ 5,519,280
			Engineering, Permitting and Administration (25% of Construction)	\$ 1,379,820
			TOTAL PROJECT COST	\$ 6,899,100
			ROUNDED TOTAL	\$ 6,899,000

Subsampling/Sorting/Handling Facility				
Sorting/Handling Facility	1	LS	\$ 9,260,000	\$ 9,260,000
			Construction Subtotal	\$ 9,260,000
			Construction Contingencies (30%)	\$ 2,778,000
			SUBTOTAL, CONSTRUCTION COSTS	\$ 12,038,000
			Engineering, Permitting and Administration (25% of Construction)	\$ 3,009,500
			TOTAL PROJECT COST	\$ 15,047,500
			ROUNDED TOTAL	\$ 15,048,000

**Relicensing Fish Passage Study
Lewis River Hydroelectric Projects
Draft Level Cost Estimate
February, 2001**

Swift No. 1 Modified Spillway Surface collector
--

<u>Item</u>	<u>Quantity</u>	<u>Unit</u>	<u>Unit Cost</u>	<u>Cost</u>
Surface Flow Diversion and Screens				
Miter Gate	645,000	LBS	\$ 2	\$ 1,290,000
Modifications to existing radial gate	1	LS	\$ 250,000	\$ 250,000
Miter Gate interface with pier	1	LS	\$ 1,500,000	\$ 1,500,000
Transport channel excavation	77,000	CY	\$ 28	\$ 2,156,000
Transport channel excavation haul	77,000	CY	\$ 10	\$ 770,000
Transport channel concrete liner	10,500	CY	\$ 750	\$ 7,875,000
Adjustable bypass control gate	2	SF	\$ 25,000	\$ 50,000
Radial control gate	4	EA	\$ 35,000	\$ 140,000
V-Screen	12,000	SF	\$ 115	\$ 1,380,000
Bypass Flow Pump Station	1	LS	\$ 150,000	\$ 150,000
Energy Dissipation Chamber	1	LS	\$ 100,000	\$ 100,000
Pipeline to Surge Tank	900	LF	\$ 375	\$ 337,500
			Item Subtotal	\$ 15,998,500
			Construction Contingencies (30%)	\$ 4,799,550
			SUBTOTAL, CONSTRUCTION COSTS	\$ 20,798,050
			Engineering, Permitting and Administration (25% of Construction)	5,199,513
			TOTAL PROJECT COST	\$ 25,997,563
			ROUNDED TOTAL	\$ 25,998,000

Subsampling/Sorting/Handling Facility				
Sorting/Handling Facility	1	LS	\$ 9,260,000	\$ 9,260,000
			Item Subtotal	\$ 9,260,000
			Construction Contingencies (30%)	\$ 2,778,000
			SUBTOTAL, CONSTRUCTION COSTS	\$ 12,038,000
			Engineering, Permitting and Administration (25% of Construction)	3,009,500
			TOTAL PROJECT COST	\$ 15,047,500
			ROUNDED TOTAL	\$ 15,048,000

**Relicensing Fish Passage Study
Lewis River Hydroelectric Projects
Draft Level Cost Estimate
February, 2001**

Swift No. 1 Skimmer Surface collector
--

<u>Item</u>	<u>Quantity</u>	<u>Unit</u>	<u>Unit Cost</u>	<u>Cost</u>
Floating Surface Collector				
Floating Surface Collector	1	LS	\$ 5,000,000	\$ 5,000,000
Attraction Flow Pipeline (in wet)	1	LS	\$ 65,000	\$ 65,000
Attraction Flow Pipeline (in tunnel)	1	LS	\$ 420,000	\$ 420,000
Microtunneling	180	LF	\$ 2,000	\$ 360,000
Pump Station	1	LS	\$ 150,000	\$ 150,000
Pipeline to Surge Tank	900	LF	\$ 375	\$ 337,500
Bypass Pipeline	1	LS	\$ 770,000	\$ 770,000
Energy Dissipation Chamber	1	LS	\$ 100,000	\$ 100,000
Emergency Spill Pipeline	1	LS	\$ 430,000	\$ 430,000
Concrete Retaining Wing Wall	12,100	CY	\$ 750	\$ 9,075,000
Docking Station	1	LS	\$ 200,000	\$ 200,000
			Item Subtotal	\$ 16,907,500
			Construction Contingencies (30%)	\$ 5,072,250
			SUBTOTAL, CONSTRUCTION COSTS	\$ 21,979,750
			Engineering, Permitting and Administration (25% of Construction)	5,494,938
			TOTAL PROJECT COST	\$ 27,474,688

ROUNDED TOTAL **\$ 27,475,000**

Subsampling/Sorting/Handling Facility				
Sorting/Handling Facility	1	LS	\$ 9,260,000	\$ 9,260,000
			Item Subtotal	\$ 9,260,000
			Construction Contingencies (30%)	\$ 2,778,000
			SUBTOTAL, CONSTRUCTION COSTS	\$ 12,038,000
			Engineering, Permitting and Administration (25% of Construction)	3,009,500
			TOTAL PROJECT COST	\$ 15,047,500

ROUNDED TOTAL **\$ 15,048,000**

**Relicensing Fish Passage Study
Lewis River Hydroelectric Projects
Draft Level Cost Estimate
February, 2001**

Swift No. 1 Gulper

<u>Item</u>	<u>Quantity</u>	<u>Unit</u>	<u>Unit Cost</u>	<u>Cost</u>
Floating Surface Collector				
Floating Surface Collector	1	LS	\$ 5,000,000	\$ 5,000,000
Microtunneling	180	LF	\$ 2,000	\$ 360,000
Pumps	2	LS	\$ 75,000	\$ 150,000
Pipeline to Surge Tank	900	LF	\$ 375	\$ 337,500
Bypass Pipeline	1	LS	\$ 770,000	\$ 770,000
Energy Dissipation Chamber	1	LS	\$ 100,000	\$ 100,000
Emergency Spill Pipeline	1	LS	\$ 430,000	\$ 430,000
Concrete Retaining Wing Wall	12,100	CY	\$ 750	\$ 9,075,000
Docking Station	1	LS	\$ 200,000	\$ 200,000
			Item Subtotal	\$ 16,422,500
			Construction Contingencies (30%)	\$ 4,926,750
			SUBTOTAL, CONSTRUCTION COSTS	\$ 21,349,250
			Engineering, Permitting and Administration (25% of Construction)	5,337,313
			TOTAL PROJECT COST	\$ 26,686,563

ROUNDED TOTAL **\$ 26,687,000**

Subsampling/Sorting/Handling Facility				
Sorting/Handling Facility	1	LS	\$ 9,260,000	\$ 9,260,000
			Item Subtotal	\$ 9,260,000
			Construction Contingencies (30%)	\$ 2,778,000
			SUBTOTAL, CONSTRUCTION COSTS	\$ 12,038,000
			Engineering, Permitting and Administration (25% of Construction)	3,009,500
			TOTAL PROJECT COST	\$ 15,047,500

ROUNDED TOTAL **\$ 15,048,000**

Comments and Responses on Draft Report

This section presents stakeholder comments provided on the draft report, followed by the Licensees' responses. The final column presents any follow-up comment offered by the stakeholder and in some cases, in italics, a response from the Licensees.

Commenter	Volume	Page/ Paragraph	Statement	Comment	Response	Response to Responses
WDFW – KAREN KLOEMPKEN	1	AQU 05 App 1	Tailrace and Draft Tube Barriers.	The reason for not installing tailrace and draft tube barriers for Merwin, Yale and Swift dams is because fish going through the turbines could be impinged while outmigrating. If screens or exclusionary nets were installed at or near the intakes fish wouldn't be going through the turbines, so those tailrace and draft tube barriers could be installed.	The Licensees believe MWH makes a good argument for why tailrace barriers are not needed. We have been unable to locate a report for Winchester dam that supposedly documents mortalities from fish entering draft tubes, and have not found any other studies that document draft tube mortalities. On the other hand there have been two recent studies that have shown that steelhead and salmon do not attempt to swim up draft tubes that are by far much more accessible than the project draft tubes on the Lewis (studies conducted on Powerdale on Hood River and the Oak Grove project on the Clackamas River in Oregon.) We do not believe evidence exists that points to the need for tailrace barriers, which is why we have not requested that MWH study the feasibility.	

Commenter	Volume	Page/ Paragraph	Statement	Comment	Response	Response to Responses
WDFW – KEN BATES	5	AQU 05 App 1 p. 3	2.1 Run Timing Design Values.	Design for downstream passage facilities are designed to operate during 4 spring months. Should have capability of year round operation – there will likely be some fish outmigrating in all months	<p>The stated 4-month operational criteria were selected due to fish run timing. The actual system will be capable of operating for longer periods based on reservoir elevations in any given year. For example, statistically the Merwin system can operate from February through September. See Fig 2.2-3, pg 7.</p> <p>Fish run timing data collected on northwest rivers indicates that the majority of anadromous juveniles migrate from March through October of each year. Reservoir elevations proposed accommodate this run timing.</p>	
J. Kaje – Tech.Adv. for Cowlitz Tribe	5	AQU 05 App 1 – Page 3, last para	“It is important to point out that a formal non-operational period would require further study to determine its impact on both kokanee and bull trout”	When will this issue be discussed by the ARG?	While this was pointed out by the consultant, we would not think that the proposed time period would have much of an impact on bull trout or kokanee. As with many Columbia River basin projects, a window will be formally determined for doing maintenance activities.	

Commenter	Volume	Page/ Paragraph	Statement	Comment	Response	Response to Responses
J. Kaje – Tech.Adv. for Cowlitz Tribe	5	AQU 05 App 1, p.4, Figure 2.1- 1	chum data	The upstream timing for chum is not clear in the figure.	This figure will be clarified in the final report.	
J. Kaje – Tech.Adv. for Cowlitz Tribe	5	AQU 05 App 1, p.5, section 2.1.2, 2 nd para	“Due to the report’s stated intent, the downstream collection window takes into account bull trout, Pacific lamprey, or kokanee.”	Syntax error. I believe this is intended to say that these species are NOT taken into account. The lamprey migration window in particular has no overlap at all with the downstream passage facility operational window.	Thank you for pointing out the omission of this key phrase. Even though these systems are not specifically designed for these species, they would assist in passing (except possibly lamprey) these species when they are operational. The lamprey migration window will be verified.	
WDFW – KEN BATES	5	AQU 05 App 1 p. 5	2.2 Reservoir And Tailwater Design Elevations.	<p>Tailwater and reservoir flow patterns are also critical. High and low reservoir and tailwater elevations are proposed for the design of fish passage facilities. No justification or reasoning is provided for the proposed design water levels. It appears that the design range is intended to be within the 10 and 90% exceedence daily reservoir levels during the migration season. There are some situations that don’t come close to achieving that goal however.</p> <p>From WDFW Phase 1 report comments, “The hydrology standard generally accepted for the design and operation of upstream fish passage is for the fish passage criteria to be complied with 90% of the time</p>	<p>The intent in addressing and selecting reservoir elevations is to accommodate the 10%/90% exceedence flows during fish migration seasons. Specific elevations were limited (i.e., Yale Reservoir) in an effort to limit reservoir fluctuation to improve system operation. This report provides a framework and statistics that will allow future discussion of operational elevations after flood operational curves are selected and biological system goals are defined.</p> <p>The entrance design for upstream fish passage</p>	

Commenter	Volume	Page/ Paragraph	Statement	Comment	Response	Response to Responses
				<p>during the migration period, rather than for the flows between the annual 10 and 90% exceedence flows. The standard should be applied to each migration period (species) of interest. Downstream passage facilities should ideally be designed to be functional at all flows, but some facilities such as operation of an in-river screen may require special consideration.“ These suggestions have not been addressed.</p> <p>Extreme water levels below Merwin were requested in our Phase 1 review but are not provided or explained. Are there extreme low flows at which the upstream fish passage facilities will not operate? The error bars in the water level figures “document historical reservoir elevations.” (2.2.1) Are these the extreme for the period of record? What is the period of record in each case?</p>	<p>facilities at Merwin is intended to operate at an extreme low elevation of 46.0 ft msl.</p> <p>Exit conditions for a trap and haul system can accommodate all extreme reservoir elevations.</p> <p>Exit conditions for a ladder exit into the Yale Lake are designed to operate between May and September. An additional slide-type exit could be added to the ladder if selected for implementation during detailed design.</p> <p>Error bars show extreme reservoir levels from Jan 1, 1989 – Dec 19, 2000. Dates are shown in the Phase 1 Report and were inadvertently left off Phase 2 figures.</p>	
WDFW – KEN BATES	5	AQU 05 App 1 p. 5 (cont.)	2.2 Reservoir And Tailwater Design Elevations (cont.).	<p>Yale upstream fish passage design level of 231.5 is exceeded (operation is lower than the design level) more than about 10% of the time during seven of the eleven months identified as the fish passage season. (Fig 2.2-5) The figure should be modified to specifically show bull trout migration</p>	<p>The system designed as shown could be operated during the June – August maintenance period. The figure can be revised to show year round adult migration.</p>	

Commenter	Volume	Page/ Paragraph	Statement	Comment	Response	Response to Responses
				<p>periods.</p> <p>The low Swift No 2 upstream fish passage design level of 474.0 is exceeded (operation is lower than the design level) more than about 50% of the time during six of the eleven months identified as the fish passage season. (Fig 2.2-9) The figure should be modified to specifically show bull trout migration periods.</p> <p>Flow releases made to draw down reservoirs for spillway inspections may motivate movement of upstream and downstream migrants. Facilities should be provided for continuous operation during the inspection drawdowns. (Fig 2.2-2)</p>	<p>Comment noted, but be aware that Swift No. 2 tailwater elevations are a function of the level of Yale Lake; and the long term operating level of Yale lake isn't likely to be dictated by the Swift No. 2 repair.</p> <p>Inspection periods are once every 5 years during natural low flow periods. Discharge is generally made via turbines with a minor increase in base flows. Design of permanent facilities for infrequent events would be complicated and costly.</p>	
J. Kaje – Tech.Adv. for Cowlitz Tribe	5	AQU 05 App 1, p.5, section 2.2	Section general comment	Many of the proposed elevation ranges for reservoirs and tailwater areas appear inadequate to capture fish during a high % of migration days/years. For example, in several cases the elevation “window” is positioned at the 50% exceedence flow during key migration periods.	Facilities illustrated are designed to operate over the majority of the adult and juvenile migration season. For the Phase 2 Report, professional judgment was used to somewhat limit reservoir fluctuations to	<p>Thank you for the extensive response.</p> <p>Your explanation of the pumping/chute option for release into the reservoir is helpful.</p>

Commenter	Volume	Page/ Paragraph	Statement	Comment	Response	Response to Responses
				<p>This means that a contingency system – such as trap and haul – would be operating a very high percentage of the time even in a “volitional” scenario. Also, even the contingency methods rely on the ability to capture fish, so tailwater elevation ranges for collection systems in the upstream direction need to be operable at all flow levels. This can be achieved through either engineering solutions or operational changes that decrease fluctuation ranges.</p>	<p>levels that don’t always meet the 10% exceedence levels/flows during the outmigration season for juveniles. The proposed operational levels are clearly shown in this section. The hypothesis behind limiting the proposed reservoir operational levels is that permanent fish passage facilities will operate more efficiently over a limited fluctuation level.</p> <p>Upstream passage facility entrances are designed to operate at all reservoir/tailwater elevations. Note that tailwater elevations near the shown ladder entrances is not always controlled by reservoir levels. At extreme low flow events the natural channel controls tailwater elevations, not the reservoir.</p>	<p>However, unless I am very wrong about the meaning of the figures, there are still several cases where it appears that proposed facilities have substantial gaps in coverage over less than extreme tailwater elevations. For example, Figure 2.2-5, Yale Tailwater – It appears that in October, the proposed Low Elevation only meets the 50% exceedence line. The same can be said for Figure 2.2-9, Swift #2 Tailwater with the proposed Low Elevations only reaching 50% exceedence during the Spring chinook migration period, and again in the fall during coho and winter steelhead migration.</p> <p>Please clarify or address these issues. Thank you.</p> <p>Licensees’ Response: <i>After further review of the figures presented in Section 2.2, it is clear that there are 3 issues which the audience should be concerned with relative to the proposed design elevations. The following will help to better explain these design parameters.</i></p> <ol style="list-style-type: none"> <i>Design of upstream fish</i>

Commenter	Volume	Page/ Paragraph	Statement	Comment	Response	Response to Responses
						<p><i>collection facilities requires an understanding of the water level fluctuations and duration by season near a fishway entrance. The following intent of the figures is to overlay upstream fish migration seasons with operational levels near the fishway entrances:</i></p> <ul style="list-style-type: none"> ▪ <i>Figure 2.2-1 Merwin Tailwater</i> ▪ <i>Figure 2.2-5 Yale Tailwater</i> ▪ <i>Figure 2.2-9 Swift No. 2 Tailwater</i> <p><i>The Merwin chart is accurate, as there is no reservoir below the fishway entrance. The Yale and Swift No. 2 charts, however, may be misleading, as the 90% exceedence curves shown relate to the reservoir levels. The actual tailwater near the fishway entrances shown on the drawings will never drop to the recorded low downstream reservoir levels, as each dam was constructed with the powerhouse discharge elevation at the natural channel. Therefore, the low tailwater conditions near the powerhouses are controlled by open channel flow conditions in the natural channel leading</i></p>

Commenter	Volume	Page/ Paragraph	Statement	Comment	Response	Response to Responses
						<p><i>from the tailraces, and not the low reservoir levels. These charts will be revised and/or notes added to illustrate this point. All of the conceptual designs presented for fishway entrances were developed to allow full function at the lowest recorded tailwater near the entrance, and there should be no concern for non-operational periods.</i></p> <p><i>2. The upstream passage facilities also require an understanding of the water elevations where fish are to be released, such as the reservoirs upstream of each dam, or the natural river channel above Swift No. 1. The following charts:</i></p> <ul style="list-style-type: none"> ▪ <i>Figure 2.2-2 Merwin Reservoir</i> ▪ <i>Figure 2.2-6 Yale Reservoir</i> ▪ <i>Figure 2.2-10 Swift No. 1 Reservoir</i> <p><i>show a fishway exit elevation at less than the 90% exceedence level. These instances will only affect the design of a fish ladder exit or exit facility to the reservoir. As described in the responses, a slid- type release would allow fish to be</i></p>

Commenter	Volume	Page/ Paragraph	Statement	Comment	Response	Response to Responses
						<p><i>discharged at these lower levels. An additional concept would be a multi-port fishway exit. These lower elevations would have not affect on trap-and-haul fish releases, as trucks or other transport devices could discharge fish directly to the lower levels.</i></p> <p><i>3. Regarding downstream collection facilities, design elevations shown for both Merwin and Swift No. 1 in Figures 2.2-3 and 2.2-11 respectively propose elevations that will meet the 90% exceedence value. The only compromise proposed regarding downstream elevations was for downstream collection facilities at Yale Dam, as shown in Figure 2.2-7. The low elevation (474.0) was based on the 50% exceedence value on April 1st, indicating a limited performance window from April 1 to ~May 15, where the 90% exceedence value is achieved. A lower elevation of ~465, or 9 feet lower, would be required to meet the 90% exceedence values in April. Total operational ranges to consider at this site could range from the proposed 474.0 to</i></p>

Commenter	Volume	Page/ Paragraph	Statement	Comment	Response	Response to Responses
						<p><i>490.0 (16 feet of fluctuation) to 465.0 to 490.0 (25 feet of fluctuation). As stated in the response to the initial comments, professional judgment was cited to propose the lesser 16 foot fluctuation with the intent of increasing the operational efficiency of this design. Should the ARG decide to increase the operational range, it could be accommodated at a higher cost, and potential loss of operational efficiency during the migration season. Potential benefits would be to have a fully functioning facility on the margins of each run over the life of the project. The release point of any downstream bypass facility could be easily designed to meet all flow conditions, similar to the situation in Item 1 above.</i></p>
J. Kaje – Tech.Adv. for Cowlitz Tribe	5	AQU 05 App 1, p.6, Figure 2.2-2 and following para	“...the primary upstream facilities would operate for nearly all of the 90 % exceedence flows when fish	Figure: Mid Sept-November window appears to be insufficient for perhaps 30% of observed flows, though exceedence curves are only provided for 10, 50 and 90. This period is during the peak of coho, chum and sea-run cutthroat migration.	See above response. Note specific elevations on the trap-and-haul and ladder entrances: they are all designed to operate at extreme flows. The issue is with the exit. Pumped water could supply the ladder exit,	See above response to AQU 5 Appendix 1, page 5 Section 2.2.

Commenter	Volume	Page/ Paragraph	Statement	Comment	Response	Response to Responses
			are present”		and fish could be discharged to the reservoir down a slide / chute structure. Project operations also need to be considered when discussing reservoir/tailwater anticipated elevations.	
J. Kaje – Tech.Adv. for Cowlitz Tribe	5	AQU 05 App 1, p.8, Figure 2.2- 5	Yale tailwater figure	Similar to comment above. Tailwater elevation window is set at 50% exceedence flow during a critical migration period for coho and chum in particular. This implies trap and haul 50% of the time even in a volitional scenario.	See above responses. This does not imply trap-and-haul operation. The entrances will operate; the exit is the challenge. Again, please note the design elevations shown on the drawings.	See above response to AQU 5 Appendix 1, page 5 Section 2.2.
J. Kaje – Tech.Adv. for Cowlitz Tribe	5	AQU 05 App 1, p.9, Figure 2.2- 6	Yale reservoir elevation	October – March elevation window at only 50% exceedence. This seriously affects ability to pass coho, winter steelhead, chum and early spring chinook.	See above responses.	See above response to AQU 5 Appendix 1, page 5 Section 2.2.
J. Kaje – Tech.Adv. for Cowlitz Tribe	5	AQU 05 App 1, p.11, Figure 2.2- 10	Swift #1 reservoir	October – December elevation window seriously affects ability to pass coho, winter steelhead and cutthroat.	See above responses.	See above response to AQU 5 Appendix 1, page 5 Section 2.2.
J. Kaje – Tech.Adv. for Cowlitz Tribe	5	AQU 05 App 1, p.11, Figure 2.2- 9	Swift #2 Tailwater	October – March elevation window at only 50% exceedence. This seriously affects ability to pass coho, winter steelhead, and early spring chinook.	See above responses.	See above response to AQU 5 Appendix 1, page 5 Section 2.2.
J. Kaje – Tech.Adv. for Cowlitz Tribe	5	AQU 05 App 1, p.13, Figure 2.2- 12	Swift #2 tailwater	This appears to be the wrong figure – upstream instead of downstream	Thank you for pointing this out. Figure 2.2-12 will be modified to show the same fish migration window as depicted on Figure 2.2-11.	

Commenter	Volume	Page/ Paragraph	Statement	Comment	Response	Response to Responses
WDFW – KEN BATES	5	AQU 05 App 1 p. 13	2.3 Design Flows.	<p>There is no explanation of the design flows chosen other than the 10 and 90% exceedence flows are the “basis for examining fish passage facilities.” As stated previously, the 10 and 90% exceedence flows are not appropriate for design of downstream passage facilities.</p> <p>Assumptions of downstream passage timing are made “for the purpose of this analysis...” For example, the low Swift No 1 downstream fish passage design level of 960.0 appears to be based on the outmigration timing of just four spring months. It should be and operated to comply with downstream fish passage criteria any time during the identified passage season.</p> <p>The implication of exceeding design levels and/or flows should be clearly stated. The efficacy of the proposed reservoir exceedence levels as design limits depends on the consequences of operations relative to the infrequent reservoir levels. The consequences are obviously different if the fish passage facilities cannot be operated at a given water level compared to a situation in which they can be operated but just not optimally. When design flows are exceeded, fish passage is usually still</p>	<p>As discussed during the planning and initial drafts of the report, reservoir operational levels, hydropower generation, and flood control are all interdependent.</p> <p>The overall assumption in preparing the fish passage study was that reservoir operations would remain nearly the same as current conditions. This will ultimately be dependent on a balance between generation and operational flexibility, flood control rule curves, and operational considerations for fish passage.</p> <p>The intent in identifying reservoir design elevations that do not accommodate some of the more infrequent extreme low flow events was to identify a more limited operational range that would allow for a narrower fish passage facility operating band, and presumably better operating facilities.</p> <p>We agree that more details</p>	

Commenter	Volume	Page/ Paragraph	Statement	Comment	Response	Response to Responses
				provided though not at its optimum. We don't accept design reservoir levels or flows without a better explanation of their implication to the design of facilities.	should be provided during the design of any facilities identified during the settlement process.	
WDFW – KEN BATES	5	AQU 05 App 1 p. 14	2.4 Operational Considerations.	How do future operations relate to historical records upon which the hydraulics, hydrology and fish facilities are based? Will facilities be designed and the projects operation to comply with fish passage design criteria a specific percentage of the time?	For planning purposes, operations are not expected to change significantly over existing conditions except where desirable to support flood control efforts.	
WDFW – KEN BATES	5	AQU 05 App 1 p. 15	3.0 Fish Passage System Development.	Some detail comments from Phase 1 letter remain unresolved but won't be repeated here.	These details are part of the record to be addressed on a site- specific basis during the design of any fish passage facilities.	
J. Kaje – Tech.Adv. for Cowlitz Tribe	5	AQU 05 App 1, p.29, Figure 3.2-7	System #7	Not clear from figure or text description why System #7 does not include an upstream passage entrance at the upstream end of the bypass reach when bull trout are supposedly the focal species. This issue should be discussed.	The intent with this entire section is to provide facilities to meet all alternatives. If management decisions are made to provide bypass reach flows and to allow fish migration into the reach, the ladder entrance shown for other alternatives can be added to this system	
J. Kaje – Tech.Adv. for Cowlitz Tribe	5	AQU 05 App 1, p.32, Section 4.0	Section general comment	Every upstream passage system – whether trap and haul or volitional – begins with the assumption that the current Merwin trap entrance can be utilized with some modification. WDFW has certainly expressed	There are varying regarding the need and means required to improve the Merwin Trap entrance. Concerns regarding future improvements should focus	Thank you for your comments regarding parameters for future improvements. Please include these in the report. It seems insufficient to consider

Commenter	Volume	Page/ Paragraph	Statement	Comment	Response	Response to Responses
				<p>serious reservations about the efficiency of the trap, and the level of stress placed on fish due to severely antiquated handling facilities. It is generally disappointing that no other options have been considered involving an entirely new entrance that is located away from the draft tubes, perhaps away from the dam itself. At a minimum, the efficiency of the current trap opening needs to be quantified and compared to more modern configurations elsewhere.</p>	<p>on the following parameters:</p> <ol style="list-style-type: none"> 1) Effectiveness of trap entrance, for all required operational flows, tailwater levels, and project operational scenarios when upmigrating target species are present. 2) Efficiency and ease / lack of fish stress, for fish to move volitionally to the extent possible from the trap entrance to the trap's fish lift. Consider numbers of fish at peak and normal runs, and ability to enter the trap under own volition or efficient crowder system. 3) Size and operational efficiency to transport peak runs up the fish lift and transfer to transport facilities. Transport facilities provided to date for consideration include a truck loading station, a fish lift, and a fish ladder. 4) Health and safety concerns for operating personnel. Any improvements to the existing 	<p>the efficacy of the current trap as a matter of "varying views between the Licensee's biologists and WDFW biologists and operational staff". It seems appropriate to conduct studies of the efficiency of the trap in its current condition, particularly under various operational scenarios. If the entire portfolio of upstream solutions is tied to modification of the existing trap entrance, then the topic deserves focused attention.</p> <p>Licensees' Response:</p> <p><i>Additional descriptions have been added to Section 4.3.1.2 of the Fish Passage Report presented in AQU 5 Appendix 1.</i></p>

Commenter	Volume	Page/ Paragraph	Statement	Comment	Response	Response to Responses
					trap will carefully evaluate and identify changes to improve operational health and safety issues to modern levels as required by OSHA, and WISHA.	
WDFW – KEN BATES	5	AQU 05 App 1 p. 35	4.3 Merwin Dam Upstream Alternatives.	Pacific Lamprey is not included on the list of target species. If they are present, they should be considered a primary target at all facilities to be sure they are not blocked or injured in facilities due to its clinging characteristic.	Comment noted. Can be addressed during any specific facility design.	
WDFW – KEN BATES	5	AQU 05 App 1 p. 36	4.3.1.1 Draft Tube.	There is a risk that fish will enter the draft tubes and be injured by either direct contact to the runners, being swept against draft tube walls, or by shear forces. No tailrace barrier is proposed. There is an added risk of the divided draft tube. Similar draft tubes at other locations have resulted in complex flow patterns so surging and reverse flows occur at points in the draft tubes thus increasing risk of fish entering draft tube. Consider electric barrier high in the draft tubes.	Comments noted. This can be addressed as appropriate during final design of any facilities.	
WDFW – KEN BATES	5	AQU 05 App 1 p. 38	4.3.1.2 Fish Ladder Entrance.	Fishway entrance flow has been increased from 33 through a single entrance to three entrances, each with 33 cfs. That is 0.9% of the fish passage design flow. All entrances may not have to operate at all flow conditions. I suggest a fishway	Concerns regarding future improvements should focus on the following parameters: 1) Effectiveness of trap entrance, for all required operational flows, tailwater	

Commenter	Volume	Page/ Paragraph	Statement	Comment	Response	Response to Responses
				<p>entrance flow of 300 cfs.</p> <p>Additional hydraulic control will be needed to distribute flow to the three entrances. Additional telescoping weirs in two of the fishway legs would be appropriate. Trapping and crowding facilities should be included within the lower end of the fishway to as part of the backup fish lift capabilities.</p> <p>The floor of the fishway is elevation 46.0, the same as the low tailwater. At least one fishway leg should be modified to provide a minimum of four feet of depth at lowest tailwater.</p>	<p>levels, and project operational scenarios when upmigrating target species are present.</p> <p>2) Efficiency and ease / lack of fish stress, for fish to move volitionally to the extent possible from the trap entrance to the trap's fish lift. Consider numbers of fish at peak and normal runs, and ability to enter the trap under own volition or efficient crowder system.</p> <p>3) Size and operational efficiency to transport peak runs up the fish lift and transfer to transport facilities. Transport facilities provided to date for consideration include a truck loading station, a fish lift, and a fish ladder.</p> <p>4) Health and safety concerns for operating personnel. Any improvements to the existing trap will carefully evaluate and identify changes to improve operational health and safety issues to modern levels as required by OSHA, and WSHA.</p> <p>An evaluation of the existing</p>	

Commenter	Volume	Page/ Paragraph	Statement	Comment	Response	Response to Responses
					trap operation can be discussed further as appropriate during settlement discussions. Suggest any settlement position on the Merwin Trap entrance consider the above four items.	
WDFW – KEN BATES	5	AQU 05 App 1 p. 40	4.3.2 Merwin – Existing Fish Lift.	An enlargement of the existing trap is proposed to ease operational constraints and to improve worker safety. The expansion should include fish trapping, holding, and crowding and potentially additional auxiliary water supply. No details are provided in the plans for evaluation of the expansion.	This comment has been noted. Details can be developed during final design efforts.	
J. Kaje – Tech.Adv. for Cowlitz Tribe	5	AQU 05 App 1, p.40, Section 4.3.2	“Comments received on this concept expressed concern regarding the double handling of fish (fish to truck to sorting facility, sorting facility to truck to final destination)”	It is important to note that under the current trap configuration, fish would be triple handled in this scenario. Workers presently have to wrestle each fish individually into the lift to begin with, after crowding them into a corner.	As stated, this alternative would require more handling than others. The amount of handling and effects on fish survival and fish health will depend on the final design details, and amount of automation or manual handling desired. It is stated that the entrance to the current trap will be improved. All designs allow for modern, more efficient handling facilities that could be designed to minimize fish stress during each handling cycle.	

Commenter	Volume	Page/ Paragraph	Statement	Comment	Response	Response to Responses
WDFW – KEN BATES	5	AQU 05 App 1 p. 41	4.3.3 Merwin – Ladder to Holding Ponds.	A pescalator is suggested as an alternative to a fishway. Site topography doesn't appear conducive for the pescalator. For this much elevation gain, a pescalator would have to be about 80 feet long. I doubt the technology is available for such a device. They are generally built about 40 feet long.	Site grading would be modified to balance rock excavation versus available pescalator-type technology. Further analysis is anticipated during any final design phase if this alternative is carried forward.	
WDFW – KEN BATES	5	AQU 05 App 1 p. 43	4.1.1 Yale – Draft Tube.	No tailrace barrier is proposed. Our comments from Merwin apply here also. Consider electric barrier high in the draft tubes.	The Licensees believe MWH makes a good argument for why tailrace barriers are not needed. We have been unable to locate a report for Winchester dam that supposedly documents mortalities from fish entering draft tubes, and have not found any other studies that document draft tube mortalities. On the other hand there have been two recent studies that have shown that steelhead and salmon do not attempt to swim up draft tubes that are by far much more accessible than the project draft tubes on the Lewis (studies conducted on Powerdale on Hood River and the Oak Grove project on the Clackamas River in Oregon.) We do not believe evidence exists that points to the need	

Commenter	Volume	Page/ Paragraph	Statement	Comment	Response	Response to Responses
					for tailrace barriers, which is why we have not requested that MWH study the feasibility.	
WDFW – KAREN KLOEMPKEN	1	AQU 05 App 1 p. 43	Fish Lochs.	Why was the option of fish locks removed from consideration and no cost options developed for all of the dams in the Project?	A fish lift is considered more technically feasible than fish lock due to cost and fish transport cycle timing. Costs for facilities at other dams can be extrapolated for planning purposes from the cost detail provided.	
WDFW – KEN BATES	5	AQU 05 App 1 p. 48	4.5.1.1 Swift 2 Draft tubes, 4.5.1.2 Swift 1 Draft tubes	<p>No draft tube barriers suggested. Swift 1 has the lowest draft tube velocities of the projects. Our comments from Merwin apply here also. Consider electric barriers in the draft tubes.</p> <p>A shorter fishway with a lifting hopper to a trap and haul truck should be included in the options at Yale and Swift. They would be intended for bull trout and would have a lower capacity than the anadromous design and not include the sorting facilities. They would include an entrance, auxiliary water, several (depending on tailrace variability), fishway pools, and a holding/trapping pool with a bail-hopper loading device.</p>	<p>It is not proposed that adults be released in Swift No. 2 Canal; therefore, a draft tube barrier is not necessary.</p> <p>Comment noted.</p>	

Commenter	Volume	Page/ Paragraph	Statement	Comment	Response	Response to Responses
WDFW – KEN BATES	5	AQU 05 App 1 p. 54	5.0 Downstream Passage Facilities	<p>We disagree that full exclusionary screens represent the upper bounds of screening technology. There is no reason to suggest that a single screen facility of, for example, 2000 cfs capacity couldn't be repeated in parallel modular installation three times to produce a capacity of 6,000 cfs. The limiting factor is not the scale of the diversion but the cost.</p> <p>The mention of higher approach velocities previously by WDFW is not an alternative screening criteria. Current screening criteria of 0.4 fps approach velocity is based on extreme low temperature and size of fish. From our previous letter, "That approach velocity can likely be exceeded when the severe conditions are not present."</p> <p>It's not clear how the 40-foot head differential will be dissipated in the 0.4 and 0.8 approach velocity screen designs. Screening will likely have to be distributed over the bypasses to maintain a high velocity into the bypasses especially at high forebay elevations.</p> <p>The Phase 1 report suggested that systems similar to Swift No 1 downstream facilities could be used at Yale and Merwin. Have the costs</p>	<p>The intent in identifying "upper bounds" of technology is to state that high flow, full exclusionary screens are expensive.</p> <p>Screen velocity figures were developed and costs provided for decision making purposes. The report identifies options but does not recommend any facilities.</p> <p>It will be dissipated through an energy dissipation chamber. Details will be developed during final design.</p> <p>Costs are believed to be</p>	

Commenter	Volume	Page/ Paragraph	Statement	Comment	Response	Response to Responses
				developed for Swift No 1 been validated for the other sites considering site conditions and reservoir fluctuations?	appropriate for planning efforts. Agree that site conditions can affect costs.	
WDFW – KAREN KLOEMPKEN	1	AQU 05 App 1 p. 57	Gulpers.	There is a reference to the Baker gulpers being considered successful. This is a misrepresentation of the facts. There is a gulper at the Baker Project and it does collect fish. It does not collect all outmigrating fish. Even Puget Sound Energy does not consider it successful.	We know of no fish passage facilities that successfully collect (100% guidance and 100% survival) all migrating juveniles. Thus, success is a relative term. The Baker gulper may be considered “successful” because in that system, it is able to achieve the biological goal of maintaining self-sustaining runs of anadromous fish in stream reaches above the dam. By this definition, the Baker gulper is successful.	
WDFW – KAREN KLOEMPKEN	1	AQU 05 App 1 p. 61	Gulper.	Why weren’t the guide wall and lead net concepts included in the cost estimate if these optional items could enhance the performance of this alternative? These “add on items” should have been priced out to enable a full analysis to be conducted.	In discussions within the ARG, NMFS expressed some doubt as to the feasibility of using a Gulper. Since skepticism prevailed in the discussions, not a lot of effort went into analyzing this alternative. However, the Licensees remain interested in some form of surface collection.	
WDFW – KAREN KLOEMPKEN	1	AQU 05 App 1 p. 66 para 1 & 2	6.2 System Cost Development, second sentence.	The table (Table 6.2-1) listed doesn’t match the tables in the rest of the section. Same for the second paragraph	The table on page 67 should be revised to read Table 6.2-1.	

Commenter	Volume	Page/ Paragraph	Statement	Comment	Response	Response to Responses
WDFW – KAREN KLOEMPKEN	1	AQU 05 App 1 Tab C, App A	Comment letter.	The letter in the appendix is missing page 6.	The original letter addressed to Dana Postlewaite was missing page 6. We will attempt to locate it.	